

INFO

EDUARD

VOL. 11 • ISSUE 5 • MAY 2011

E-bunny tales

 **BACK TO
CCCP**



**eduard
BRASSIN**

HISTORY:

Mission Centenarians

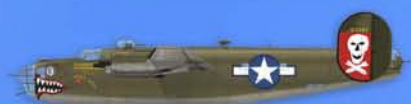

BUILT:

Mig-21MF 1/48

EVENTS:

MiG-21 bis



INFO

EDUARD

VOL. 11 • ISSUE 5 • MAY 2011

© Eduard-Model Accessories, **2011**

FREE FOR DOWNLOAD, FREE FOR DISTRIBUTION!

This material may only be used for personal use. No part of the text or graphic presentations can be used in another publication in any other media form or otherwise distributed without the prior written permission of Eduard Model-Accessories and the authors involved.

Editorial and Graphics - Marketing department, Eduard-Model Accessories, Ltd.



CONTENT



MiG-21SMT 1/48 ProfIPACK



Photo-etched details for MiG-21 1/48



MiG-21 bis



Built Su-22 1/48



4 EDITORIAL

9 KITS

- 9 MiG-21SMT 1/48
- 10 Fw 190D-11 1/48
- 11 Bf 109E over the BALKAN PENINSULA 1/32

12 PHOTO-ETCHED

14 BRASSIN

- MiG-21MF/SMT exhaust nozzle, AIM-9B Sidewinder, F-4 exhaust nozzles USN late

15 BIG-ED

16 RELEASES

May 2011

17 HISTORY

B-24D Mission Centenarians

21 BUILT

- 21 Su-22M4 1/48
- 22 MiG-21MF 1/48
- 24 Motor DB 601 1/32
- 25 Bf 109E-7 Trop 1/32

26 EVENTS

- 26 Mosonmagyaróvár
- 28 Dimensional check of MiG-21BIS

30 ON APPROACH

June 2011...

eduard

Issued by Eduard Model-Accessories, Ltd.
Mírová 170, Obrnice 435 21
info@eduard.com
www.eduard.com

EDITORIAL



The stormy world situation has gradually settled down, at least in the sense that it has lost some of the media attention. That's how it goes. As you have no doubt noticed, it's like with other forms of tragedy, such as aircraft crashes. Most attention is garnered in the few initial days, when everything about causes isn't much more than speculation. About subsequent investigations and conclusions you find out practically nothing. Case in point: Fukushima. A month ago, the newspapers and television were full of reports, but today, you're hardpressed to find more than small items. A fascinating story of the liquidation of the effects of the crash will remain, as always, and initial and focused attention in the media becomes relegated to the Discovery and National Geographic channels. But, at least there is the likelihood that the facts will be presented in an effective and serious way, assuming that Greenpeace doesn't get involved, or Al Gore or another Children of the Earth member. At least Khadafi remains defiant and demonstrates, as opposed to other Arab dictators, his skill and knowledge of his dictatorial trade. Not that I would consider myself a fan of the man, but the way that he hangs on with such determination demands, at the very least, some respect. Furthermore, his ability to stand up to such intense NATO intervention, will supply subject matter to the modeling world. At least, I would expect that appearance over Libya of operational machines will not be ignored, and that airbrushes, colors, masks and so on, are at the ready.

I am currently on vacation in the Sazava region, and I am writing this newsletter there. I was here at a show about four years ago, incidentally, a very memorable show, and I promised myself that I would come back here to spend at least some of a vacation. This year, it finally happened, and my wife and I navigate the area, and every now and then, we get soaked in rainstorms. Just today, we were greeted by three thunderstorms, and amazingly, each time we were hit, we were just passing a local bar. From time to time, a person can get a bit lucky. Sazava is a comparatively small area, but with an uncommon number of superb modelers such as Mira Senf, Petr Zatrepaek and Pepik Simon, the local pediatrician who also runs the local kids' modeling club. His influence in the developing of new and young interest in modeling, when there is so much despair over lack of same, shows that the situation may not be that tragic. In fact, there is room for optimism, as shown by the contents of this newsletter. The builder of the 1/48th scale Su-22 in the gallery is fourteen year old Filip Kosata, a member of the Sazava modeling group. Along with his brother Daniel, he is finishing off one of our MiG-21s, each one one, and I have to say that no way I'd do a better job! Sazava will see their show on June

26, 2011. Check out www.modelarskydensazava.estranky.cz. It will be smaller than ModellBrno (and follows it a week later), but it will be fresh and it will have flavor. It's a very inspirational show. Incidentally, that the situation is not all bad with respect to the influx of younger modelers can also be seen on fifteen year old's Jan Petr's MiG-21MF, also in today's gallery. His pic had over a hundred hits within 24 hours of being posted, which is highly impressive.

The modeling season is in full swing, one show is replaced by the next. As you know, we were at Moson, and, as always, our stall was packed. This year, the circus that was the show for us fit in our booth area only barely, and next year, if things continue as they have been, and they probably will, the situation is bleaker. We will need to do a bit of rethinking, and initiate some optimization for space use. I think we'll figure something out. At Moson, over catfish and Hungarian gulash, we were getting some pretty good thoughts. The show itself was awesome, as usual, despite some musings about lower attendance figures. Personally, I appreciate an analytical approach to problem solving by organizers, thanks to whom I didn't have to sleep on the banks of the Danube after all. To explain, somehow or other, it turned out that I didn't have the accommodations that I expected, but alternatives were found for me before my panic got me to the nearest sporting goods store to purchase a tent, sleeping bag, and other non-modeling necessities of life. Koszonom, Egresi Andras!

The Moson crowd had a bit of an effect on the MiG-21BIS situation. Or 'bis', if you wish, I'm not sure which to use. I've even seen 'Bis' used. In the end, we'll use the designation Izdeliye 75, and that'll be the end of that! But, back to the point. I met up with Gabor Szekeres, who very convincingly presented an argument for the differences in the MF and BIS, demanding more modifications than were previously planned. So now, to the nose section, add another 24 larger and smaller changes, such as the profile of the top of the fin, and the cannon bay. The kit will also incorporate changes in aircraft using Lazur-M system (Izdeliye 75 for Soviet air defence units, Izdeliye 75A for units of other socialist nations, and 75B for client states such as India and Finland) and machines equipped with Polyot-OI (Izdeliye or Type 75AP; Polyot was dubbed SAU in East Germany, which was picked up in western publications). Polyot/SAU was an automatic ILS landing system and characterized by large RSBN antennae under the nose and on top of the vertical tail. Lazur-M was an automatic guidance to target system, for the interceptors equipping the air defence. With this, I think I am answering some



Daniel and Filip Kosata of Sazava with their MiG-21s. You will see both these models soon on our Facebook, as well as in some of the future famous Eduard INFO issues.



I met this beauty during my trip to Prostejov. You will meet more information about the Easter Prostejov Model competition in next Eduard Newsletter.



And this one was met during backway from Prostejov in Praha – Horni Pocernice. Tell me that US Army didn't reach Prague in 1945!

frequently asked question, I hope it clears some things up. And this still hasn't addressed any of the cockpit differences! The world turns on this sort of thing, and I hope no questions will arise about specialized beer-carrying droptanks or carrot juice! If so, I will approach a small, progressive micro-brewery, and get some answers for 'ya. Here in the Sazava region, I stumbled upon a beer named 'Vitek z Prdice' (who was the founder of the Rozmberk lineage, a middle-ages nobility with influence over all of central Europe). It's really very good, and it has been quite a while since I have drunk something that refreshing.

Besides the big-tailed Doras Mosonmagyarovar saw the premiere of our T-shirts, as promised back in March and April. As of now, all three are available for sale. Or, more accurately, 'for now, all are available'. The stocks are shrinking quickly, so if you're thinking about one of these first series shirts, don't wait too long. We decided that the motifs on these shirts will be changed from series to series, so no one specific type will be available very long. At the start of May, we will be at a meet in Koprivnice, and this will, as things are going, be the last time all three will be available simultaneously. If they appear a bit too pricey, please note that the reasons for that include the quality of the printing, the size of the production run, and also the quality of the shirt itself. We picked the best of quality in all cases. The sizes are to European standard, so they will be a bit smaller than the American counterpart. Also, XXL are going fastest...not that I would draw any conclusions about the physique of the average modeler....

Koprivnice will see the premiere of the MiG-21SMT. There is greater interest being generated by this kit than was anticipated, and has led us to increasing the size of the first edition. I was basically going by the assumption

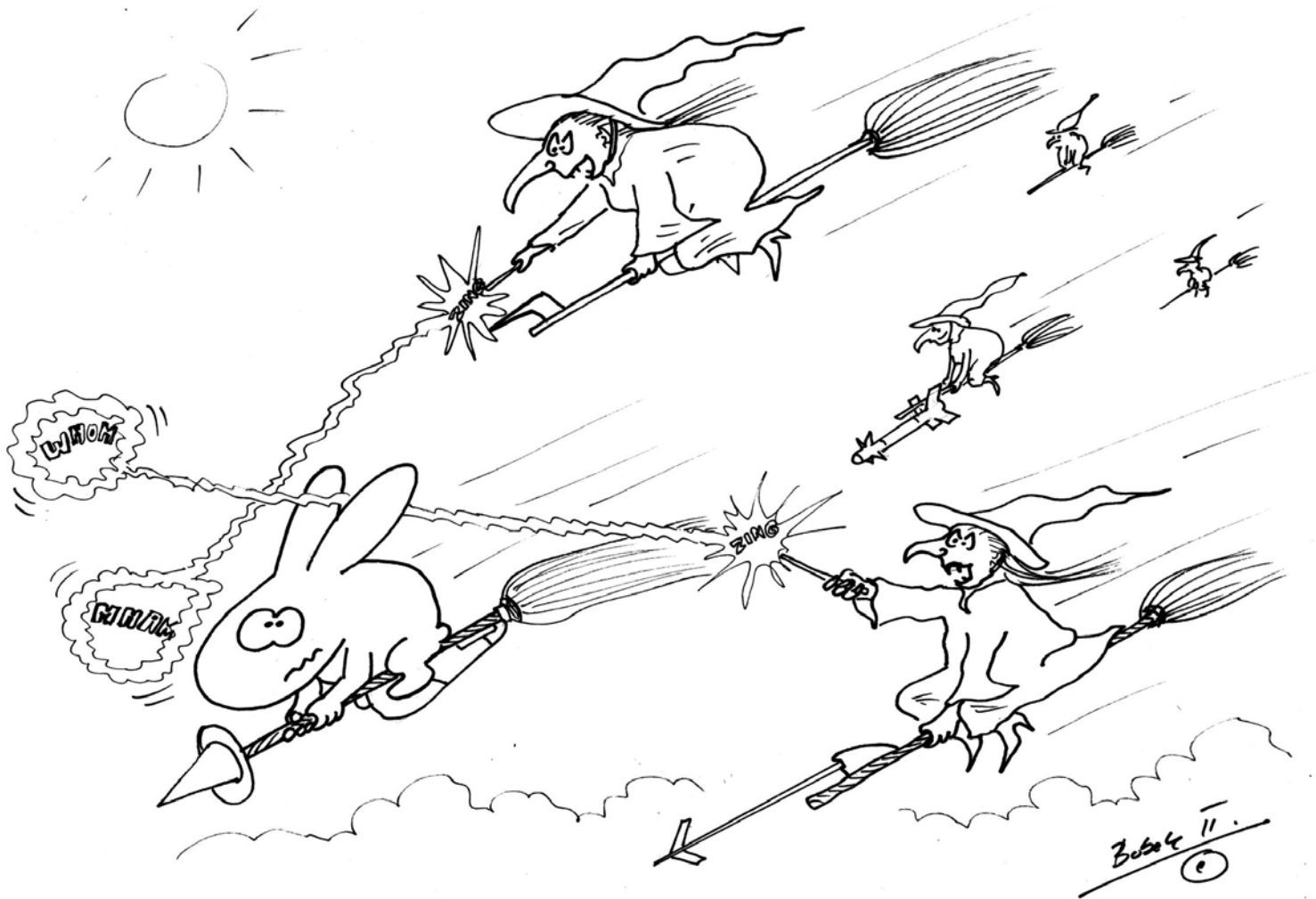

that this was a bit of a peripheral type, built in small numbers, relatively, but I see now that it commands a certain fascination among modelers. It needs to be realized that this one of the last, if not THE last, version of the MiG-21 has a very purposeful and aggressive look to it. This, despite the likelihood that it really didn't fly very well at all. Personally, I am disappointed that we were not able to dig up further details regarding the five markings options that we chose for this kit. On the other hand, we were able to come up with a great little advertisement with the Eduard Rabbit having a little adventure in Russia, or more accurately, the Soviet Union. Don't look for much logic in it; just enjoy it, and bear in mind that any resemblance to any real person, especially, God forbid, living, is strictly coincidental. Concurrent releases with the MiG-21SMT include one Limited Edition kit, the Bf 109E Over the Balkan Peninsula, and one Weekend kit, the Fw 190D-11. This is some kit to release in this series, and I am deeply pleased with the presentation and price point. Back to the Limited series....remember my promise from last month? This was the B-24D Mission Centenaries, in 1/72nd scale, for which we have included a nifty little historical writeup, and gallery.

I hope that you'll agree that the month to month release of new photoetched sets gets generally better and better. For one thing, we've finally got those long-promised and often delayed ship subjects covered, such as two sets for

the 1/350th scale USS Gearing, or 1/700th Saratoga, together with another two sets of railings in 1/350 and 1/700. There are also very attractive sets for aircraft, such as for our own MiG-21MF. Of course, we will not be neglecting other manufacturers, and are offering sets for B-17G the from Revell, for the likewise 1/72nd scale Buccaneer from Airfix, and the 1/48th scale Su-24 from Trumpeter. We are focusing more attention on 1/35th scale armor as well. Here, I would like to draw your attention towards color sets of plants for diorama work. To the already released ferns, we are adding ivy, and next month, sunflowers and grape vines. The sunflowers are freakin' amazing! I am currently inundated with ivy, and I wonder how much this has in common with our etched offering. Unlike the original parasitic item, the brass looks pretty smart, too!

The Brassin line continues to dress up our MiG-21, and May sees the exhausts on deck. Two more sets join it, one for the 1/32nd scale Tamiya naval F-4 Phantom II, and one set of AIM-9B Sidewinders in 1/48th.

And so we've had another May 1st. This region is enchanted, and the beer is good! In fact, just last night, coming from a walk after dinner, I was met by a mystical witch squadron, the fabled 'Hexengeschwader'. It was a very attractive unit; they targeted me, surrounded me.... one bounced off her nose, and one bit me in the

ear.....egads! It was better than releasing a kit of a MiG! Unfortunately, they then got back on their brooms, and flew off. But, you can't demand too much of life. I have lipstick all over my head, and I feel great. What a place!

Keep on modeling!

Vladimir Sulc



E-BUNNY TALES



BY JAN BOBEK

EDUARD - MODEL ACCESSORIES 2011

BACK TO CCCP

MOSCOW LATE 60'S

ПРОВЕРКА ПАСПОРТОВ
PASSPORT CONTROL

SO...WHAT ARE YOU GOING TO DO IN U.S.S.R.?

I WANT SEE YOUR MIG-21s, SIR

HMM, BUT YOUR PASSPORT IS NOT IN ORDER?

REALLY? I THINK EVERYTHING IS OK...

HEH!! * THERE IS "SOMETHING" NOT INCLUDED!

* : "NO"?

ИНОСТРАНЦУ? ДОМАШНУ?

CENSORED

EXCUSE ME HAVE YOU SEEN ANY...ANY...SKIRTS? OOPS...I MEAN...MIGS? EHH... HI GIRLS!

FOREIGNER

DOLLARS

EXCUSE ME, HAVE YOU SEEN SOME 21'S AROUND?

"HEIN" * ALL THE WAY TO THE RED SQUARE, I HAVE SEEN JUST SOME 25'S!

*"NO"...GERMAN PILOT MATTHIAS MUST HAVE ILLEGAL LANDING NEAR RED SQUARE, MOSCOW, ON MAY 28, 1987 WITH CESSNA 472 D

YOUR PASSPORT IS NOT IN ORDER! WHAT ARE YOU DOING IN U.S.S.R.?

MR. POLICEMAN, MY PASSPORT IS OK I'M LOOKING FOR MIG-21s

HMM, YOU HAVE NICE ЧАБЫ!!

* WATCH

WOW! MIG-21 WITH HUMPBACK AIRBASE IS NOT FAR AWAY!

MIG-21 Reconnaissance Mission 1972

EXCUSE ME IS THIS THE MIG AIRBASE? WOW!

"HEH" * THIS IS КОАХОЗ * AND I'M GUARDING IT! YOU HAVE NICE CAMERA * ARE YOU SPY??

THAT'S THE ЛУТНОН! ** TAKE HIM!!

* COLLECTIVE FARM IN SOVIET UNION

** SPY

WHO ARE YOU?? ARE YOU ШПИОН?! WHERE ARE YOU FROM? WHY YOU ARE LOOKING FOR MIGS?? TELL ME TRUTH!! NOW!!

MY NAME IS EDUARD, I'M CZECH RABBIT, I'M EXPERT IN JET FUELS, MR. PUTIN...

В.ПУТИН
С.ШЕРШУКЕ

СМЕРШ/ SMERSH: COUNTER INTELLIGENCE OF SOVIET ARMY
КГБ/ KGB: NATIONAL SECURITY AGENCY OF U.S.S.R.

ВЛАДИМИР ПУТИН/ VLADIMIR PUTIN HAS BEEN KGB AGENT FROM 1975 TILL 1999

...AND AS NEXT TOPIC, THE ISSUE WITH SUPER FAST AMERICAN RECONNAISSANCE AIRPLANES...

HMM... WHAT IS WRONG WITH OUR FIGHTERS?

3 THERE IS NOT ENOUGH ALCOHOL!

4 BORS YELTSIN IS RIGHT? SO WHY DON'T WE USE THE CZECH FUEL EXPERT MENTIONED IN LATEST KGB REPORT?

POLITBUD OF THE COMMUNIST PARTY OF U.S.S.R. FROM LEFT: E. SHEVARNADZE, S. GORBACHEV, AND B. YELTSIN (FUTURE PRESIDENT OF RUSSIAN FEDERATION AND BIG FAN OF VODKA)

OH MY... WHAT A SHAME THEY TOOK MY MONEY, WATCH, CAMERA, AND I SAW JUST MIGS IN THE AIR...

ТОБАРИ!! * EDUARD! WE ARE LOOKING FOR YOU! WE NEED YOUR HELP!

* "COMRADE" FORM OF ADDRESS IN U.S.S.R.

WOW!

THIS IS OUR NEW MIG-21 SMT. DO YOU SEE THE HUMPBACK ON THE FUSELAGE? THERE IS ADDITIONAL FUEL TANK! BUT THIS MAKES NEW "BALALAIKA" * SLOWER THAN OLDER MIG-21

МИГ-21 СМТ / MIG-21 SMT
GROSS WEIGHT 8900 KG
FUEL CAPACITY 3250 LITERS
MAX. SPEED 2175 KM/H

* BALALAIKA IS STRINGED MUSICAL INSTRUMENT OF RUSSIAN ORIGIN. ALSO NICKNAME FOR MIG-21

WE ARE TRYING TO INTERCEPT RECONNAISSANCE SR-71 BLACKBIRDS, BUT WITH THEIR SPEED MACH 3,5 THEY ARE TOO FAST...

AND HOW ABOUT DISTILLED CARROT JUICE?

WHAT??

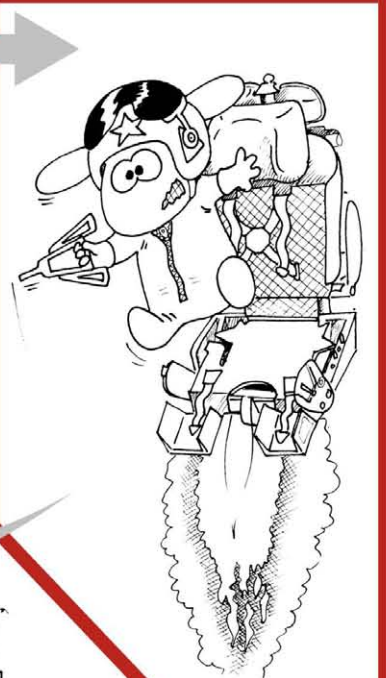
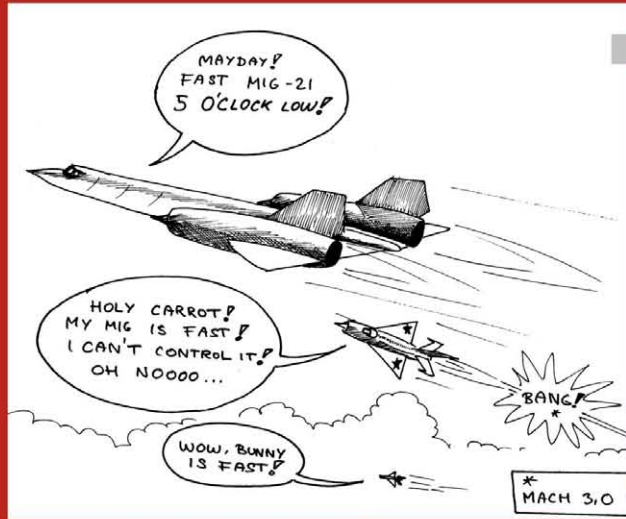
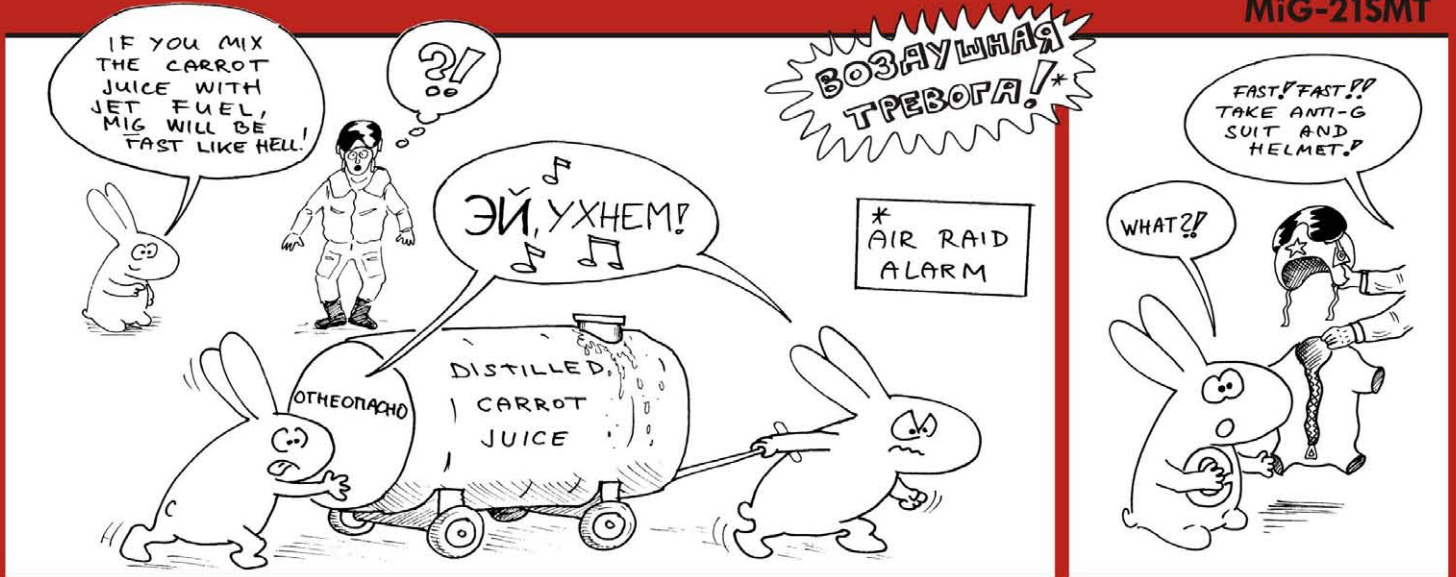

CHECK THE FINAL PART AT:

www.eduard.com/mig-21smt



E-BUNNY'S T-SHIRT WITH MiG-21 IS HERE!

MiG-21MF CZECHOSLOVAKIA



BUY

M L XL XXL

MiG-21SMT CCCP



BUY

M XL

MiG-21MF EGYPT



BUY

M L XL XXL

Limited series available in M,L, XL and XXL.
Quality material and durable printing.
Available at www.eduard.com or orders@eduard.com.

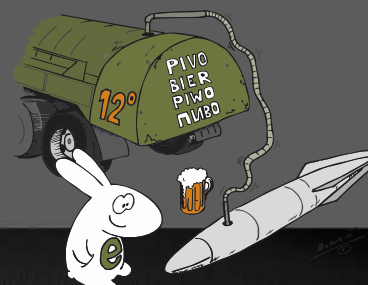

MiG-21SMT ProfiPACK Edition

1/48 Cat.No. 8233



MiG-21SMT, Krasnodar Higher Aviation Training Facility, Soviet Union, ca 1980



MiG-21MT, Serial Number 96.40.14, Dolgoye Ledovo, Russia

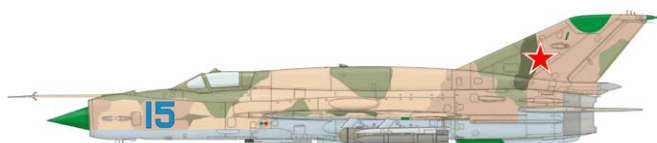

MiG-21MT, Serial Number 96.40.15, Dolgoye Ledovo, Russia



MiG-21SMT, 296th IAP, Soviet Union



MiG-21SMT, 582nd IAP, Chojna Airfield, Poland, Late Eighties



BRASSIN BONUS:
UB-16 a UB-32 rockets



BUY MiG-21SMT 1/48 ProfiPACK 

Fw 190D-11 Weekend Edition

1/48 Cat.No. 84103

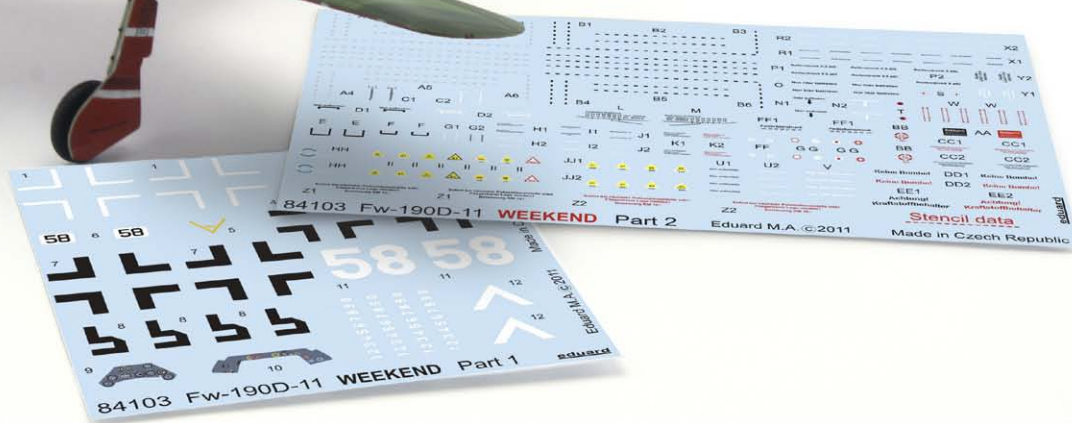

Model of Fw 190D-11 on photo above is an example only, shown camo is not included in the Weekend edition. It can be found in kits Cat.No. (ProfiPACK), 1154 (LIMITED EDITION).

Fw 190D-11, W.Nr. 2200XX, VFS des G. d. J., Bad Wörishofen, March - April 1945

Based on the post-war pictures, it is clear that Fw 190D-11 „Red 4“ from the famous „Sachsenberg Schwarm“ was previously used by Verbandsführerschule des G. d. J. under the designation „< 58“ at Bad Wörishofen. This school unit offered specialized training for fighter unit leaders. As this unit was a pilot school, the white spinner spiral, typical for frontline fighters, was not present.

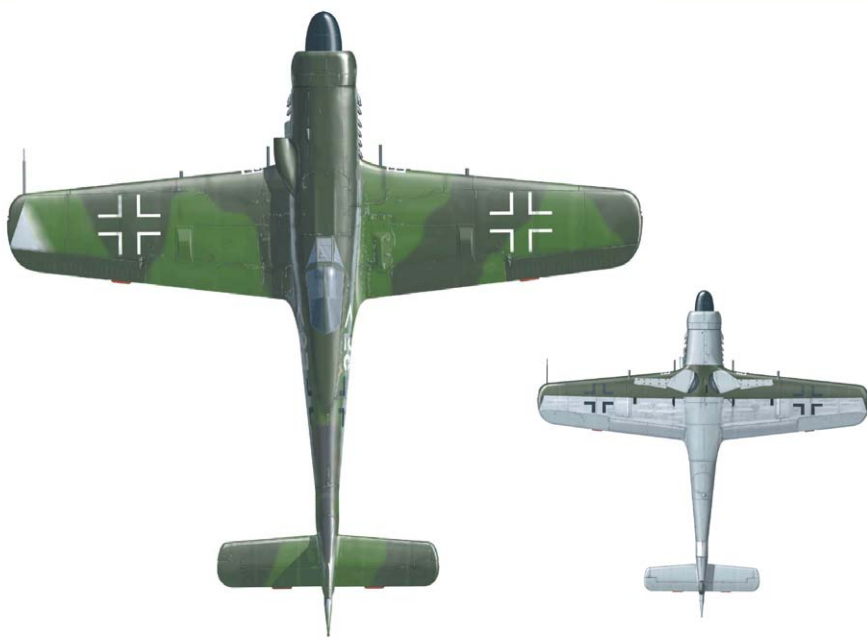

BUY Fw 190D-11 1/48

Bf 109E over the BALKAN PENINSULA LIMITED EDITION

1/32 Cat.No. 1156



Bf 109 E-4, Hptm. Max Dobislav, CO of III./JG 27, Belica airfield, Yugoslavia, April, 1941



Bf 109 E-7, III./JG 77, Belgrad – Semlin airfield, Yugoslavia, May, 1941



Bf 109 E-4, III./JG 77, Greece or Rumania, May, 1941



Bf 109 E-4, W.Nr. 4148, Hptm. Wolfgang Lippert, CO of II./JG 27, Larissa airfield, Greece, April, 1941



Bf 109 E-4/7, III./JG 77, Balkans, April, 1941

BRASSIN BONUS:
632004 Bf 109E wheels



Model of Bf 109E-1 on photo above is an example only, shown camo and subversion is not included in this limited edition.

BUY Bf 109E over the Balkan Peninsula

SELECTED PHOTO-ETCHED



36146 BMP-3 MICV
early 1/32 Trumpeter

48693 Mirage 2000B/D/N exterior 1/48 Kinetic



73381 Buccaneer S.2B S.A. 1/72 Airfix



48695 Su-24M Fencer D exterior 1/48 Trumpeter



32683 Bf 109F-4 interior S.A. 1/32 Trumpeter

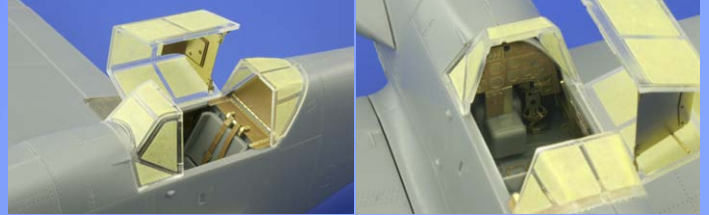

32268 Bf 109F-4 exterior 1/32 Trumpeter



For whole actual
Photo-Etched production
see page 16.

PHOTO-ETCHED

49561 S-3 interior S.A. 1/48 Italeri

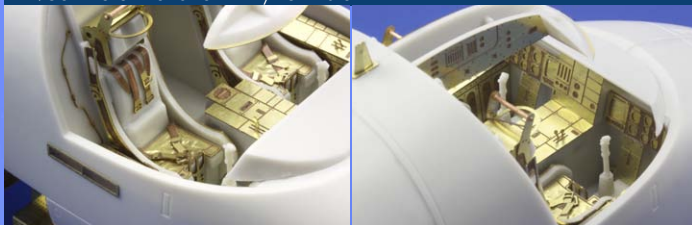

73383 B-17G rear interior 1/72 Revell



36142 M-7 Mid production interior 1/35 Dragon



36158 M-7 Mid production exterior 1/35 Dragon



48703 MiG-21MF accessories 1/48 Eduard



48703
MiG-21MF accessories
1/48 Eduard

48704 MiG-21 ladder
1/48 Eduard





648027
MiG-21MF/SMT exhaust nozzle
 1/48 (Eduard)

- engine exhaust with all accessories
- realistic reproduction of all inside and outside details



1/48

BUY MiG-21MF/SMT exhaust nozzle 1/48

648028
AIM-9B Sidewinder
 1/48

- four complete Sidewinder AA rockets
- guidance sensor ground covers
- glass parts made from clear resin
- front winglets separately
- PE set contains template for correct geometry of winglets application
- 10 Remove Before Flight labels from PE: 5 with white lettering and 5 with black lettering



1/48

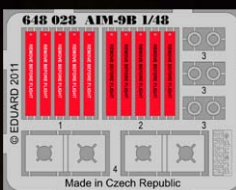

BUY AIM-9B Sidewinder 1/48

1/32

632011
F-4 exhaust nozzles USN late
 1/32 (Tamiya)

- US NAVY version
- engine exhaust with all accessories
- engine intake section
- BONUS:
- landing hook with fittings and accessories

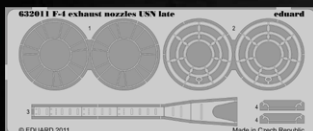

BUY F-4 exhaust nozzles USN late 1/32

BIG ED



48672 EA-6B exterior (BIG4947)



48680 EA-6B wing fold (BIG4947)



48684 EA-6B electronic equipments (BIG4947)



49520 EA-6B seatbelts (BIG4947)

BIG3300 P-40N LATE 1/32 HASEGAWA*

32259 P-40N exterior

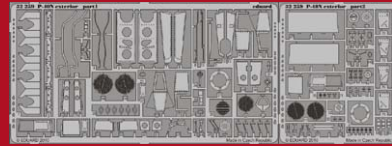

32675 P-40N late interior S.A.



32260 P-40N landing flaps

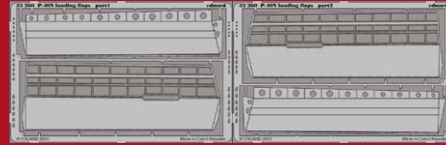

32261 P-40N gun bay

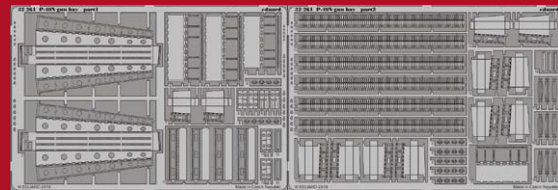

JX109 P-40N



BIG4946 A6M3 MODEL 32 1/48 TAMIYA*

49530 A6M3 model 32 S.A.

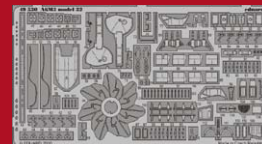

48683 A6M3 model 32 landing flaps



EX318 A6M3 model 32



BIG4947 EA-6B 1/48 KINETIC*

48672 EA-6B exterior



48680 EA-6B wing fold



49520 EA-6B seatbelts

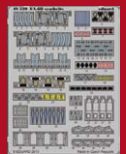

48681 EA-6B undercarriage



48684 EA-6B electronic equipments

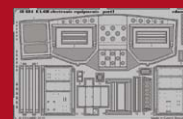

EX311 EA-6B



49519 EA-6B interior S.A.



49009 Remove Before Flight



BIG7265 F/A-18D 1/72 ACADEMY*

73364 F/A-18D S.A.

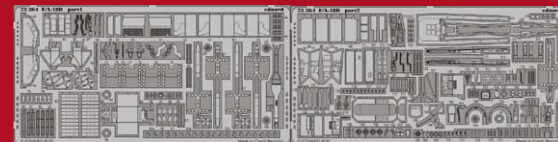

CX262 F/A-18D



73369 F/A-18D seatbelts



73008 Remove Before Flight

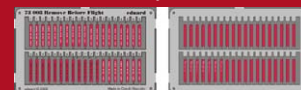

* Items of this set are displayed in the same scale

BUY BIG3300 P-40N LATE 1/32 HASEGAWA



BUY BIG4946 A6M3 MODEL 32 1/48 TAMIYA



BUY BIG4947 EA-6B 1/48 KINETIC



BUY BIG7265 F/A-18D 1/72 ACADEMY



eduard

KITS

8189	Fw 190D-9 LATE	1/48	ProfiPACK
2111	B-24D	1/72	Limited edition
84152	Albatros D.III OEFFFAG 253	1/48	Weekend

BRASSIN

648030	MiG-21 seat late	1/48	Eduard
632009	Bf 109E MG 17 mount	1/32	Eduard
632010	F-4 exhaust nozzles USAF late	1/32	Tamiya

PE-SETS

32263	MiG-23MF Flogger B exterior	1/32	Trumpeter
24013	Sparco Black 2005 1/24	1/24	
32266	Bf 109F-4 exterior	1/32	Hasegawa
32267	Ar 196A-3 exterior	1/32	Revell
32273	MiG-23MF weapons	1/32	Trumpeter
32275	Il-2 armament and bomb tails	1/32	Hobby Boss
32673	AV-8B Night Attack interior S.A.	1/32	Trumpeter
32681	Ar 196A-3 interior S.A.	1/32	Revell
36146	BMP-3 MICV early	1/35	Trumpeter
36148	Camo netting US 1940-1960 Spring	1/35	
36149	Camo netting US 1940-1960 Autumn	1/35	
36155	M-7 Mid production fenders	1/35	Dragon
36156	M-7 Mid production ammo boxes	1/35	Dragon
36162	Radio equipment WWII Wehrmacht - colour	1/35	
48692	Tornado F.3 exterior	1/48	Hobby Boss
49516	HAR. Mk.3 interior S.A.	1/48	Hasegawa
49548	Tornado F.3 interior S.A.	1/48	Hobby Boss
49549	Tornado F.3 seatbelts	1/48	Hobby Boss
49554	Ju 87B interior S.A.	1/48	Italeri
49555	Mirage 2000B interior S.A.	1/48	Kinetic

53050	Admiral Graf Spee	1/350	Academy
72515	B-17G exterior	1/72	Revell
73373	Meteor F.3 S.A.	1/72	Dragon
73385	Rafale B S.A.	1/72	Hobby Boss
99017	Railings 2 chain bars	1/700	
99018	Railings 2 chain bars	1/350	

ZOOMS

33076	Ar 196A-3 interior S.A.	1/32	1/32	Revell
FE516	HAR. Mk.3 interior S.A.	1/48	1/48	Hasegawa
FE548	Tornado F.3 interior S.A.	1/48	1/48	Hobby Boss
FE554	Ju 87B interior S.A.	1/48	1/48	Italeri
FE555	Mirage 2000B interior S.A.	1/48	1/48	Kinetic
FE559	Bf 110G-2 Weekend	1/48	1/48	Eduard
SS373	Meteor F.3 interior S.A.	1/72	1/72	Dragon
SS385	Rafale B interior S.A.	1/72	1/72	Hobby Boss

MASKS

CX283	F-16D 1/72	1/72	Kinetic
CX284	Su T-50 1/72	1/72	Zvezda
EX325	Mirage 2000B/D/N 1/48	1/48	Kinetic
EX330	Lavochkin La-5 1/48	1/48	Zvezda
EX331	Sea Harrier FA.2 1/48	1/48	Airfix
JX123	MiG-23ML Flogger G 1/32	1/32	Trumpeter
XT169	RSO Pak 40/4 75mm wheel masks	1/35	Dragon
XT170	Flak 38(f) Ausf.M late	1/35	Dragon

BIG-ED

BIG3299	Su-30 FLANKER G 1/32	1/32	TRU
BIG4944	F-22A 1/48	1/48	HAS
BIG4945	MC.200 1/48	1/48	ITA
BIG7264	F-16I SUFA 1/72	1/72	HAS

BUY on e-shop Eduard



Comments and input from J&T

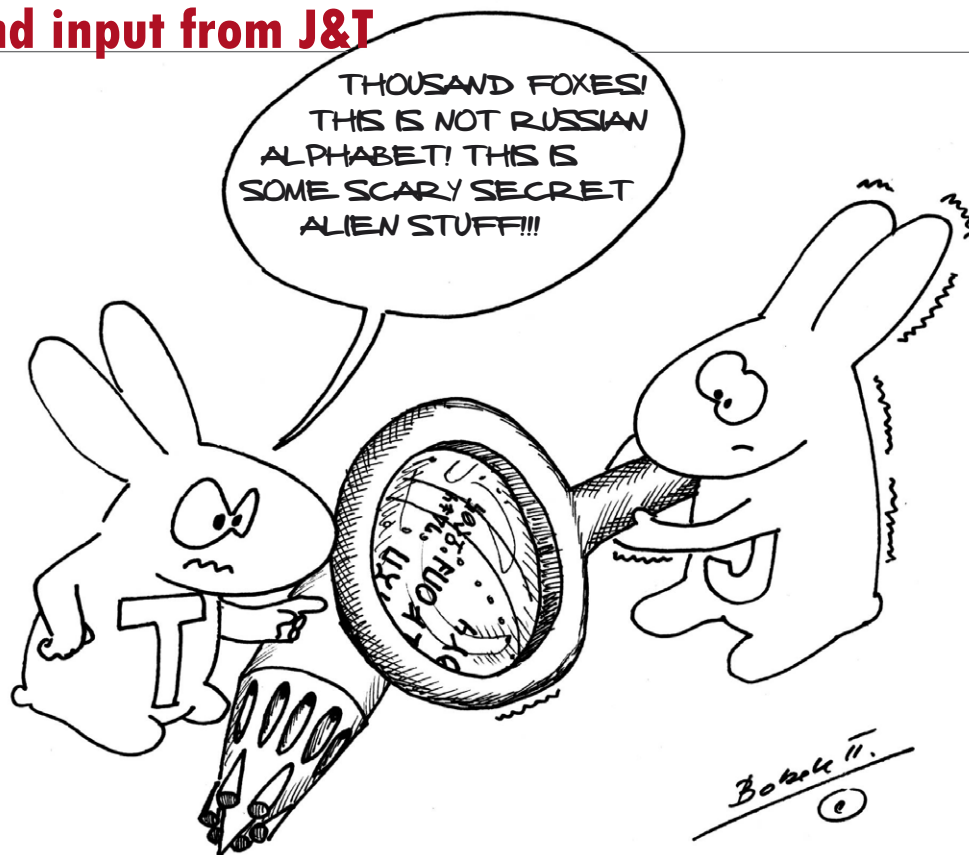



B-24D

Mission Centenarians

Mission Centenarians – this patriotic label is bestowed upon bombers that have completed one hundred missions over enemy territory. In terms of operational and non-operational losses, the milestone was significant and not possible without a constant supply of spares. For example, 'The Blue Streak' received over the course of its service life, nineteen new engines, two wings, and a replaced tail section. This much work, and repairs conducted on bullet holes and shrapnel damage, naturally had an impact on the look of the aircraft.

Such notable accomplishments of these machines demanded fully taking advantage of military resources. Famous aircraft then would find their way back to the United States and take part in mustering support through the War Bond Tours, by which the American government was able to support its war effort. For these purposes, the aircraft were often adorned with 'modeler friendly' marking schemes. This kit, Cat No. 2111, offers you three such machines. 'CHUG-A-LUG', 'MOBY DICK' and 'THE BLUE STREAK', adorned with nose art, a long line of mission markers, destroyed aircraft and ships, and inscriptions, are offered to hopefully give the best selection of subjects without requiring any other modifications. The selections chosen were inevitable – these Liberators went through a long list of modifications, including different types of turrets. The fourth aircraft – 'THE VULGAR VIRGIN' – fits the theme of this release very well, despite not actually achieving the century mission mark.

Two of the four aircraft took part in Operation 'Tidal Wave'. The purpose of this mission was to take the Ploesti oil refineries out of commission. This refinery supplied some one third of the demand of the Axis powers, and so logically found its way into the cross-hairs of the Allies.

The attacks on Ploesti were several, but the best known took place on August 1st, 1943. 178 Liberators formed over Romania, coming from the 98th BG, 376th BG, 44th BG, 93rd BG and the 389th

BG. The first two belonged to the 9th AF, the other three were from the 8th AF, transferred to Africa specifically for these raids.

The raids to and over the target were to be flown at low level, and so relevant modifications were carried out. The bombsights were replaced, the ball turrets were removed, and the bomb bays received extra fuel tanks.

The first Liberators took off at 0700h. After forming they turned towards Romania. The plan that called for low level flight ran into problems over the mountains of Albania and Yugoslavia, where a low ceiling was encountered. Navigation over unfamiliar territory also presented its problems. Some of the waves of aircraft lost their way points, and had to approach from other than planned directi-

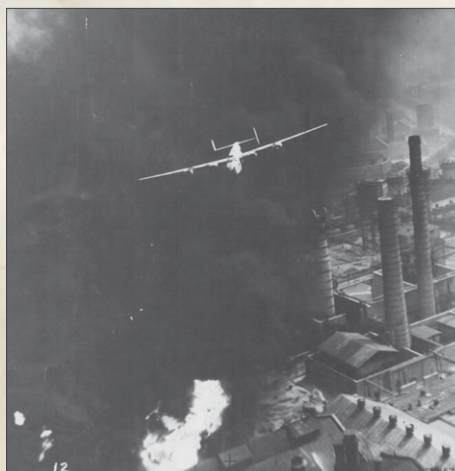

This shot taken from another B-24 gives a clear idea of how low the attacking heavy bombers flew in bombing the Ploesti fields and refineries... (taken over the Astra Romana Oil Refinery).

ons. This lost the element of surprise. The Germans naturally prepared for the eventuality of these attacks. Besides the German and Romanian air forces, the target area was well prepared and able to protect the refinery through anti-aircraft defences. The Germans spread defences around areas that they knew were likely to serve as line-up points to the target. For example, the rail line between Floresti - Ploesti was such an area, and this preparedness served the Germans well. Here, they shot down several of the attacking aircraft, including 'The Vulgar Virgin'. Besides flak, American losses were also attributed to German and Romanian fighters, and the explosions of bombs from preceding waves of bombers made things more difficult.

Some units were literally decimated. Of the eleven Liberators that were contributed by the 345th BS, 98th BG, only one returned - 'CHUG-A-LUG'. Two force landed on Sicily, one on Cyprus, six were shot down, and one was written off after a crash landing. Fifty-one airmen were lost, and nine were captured.

The results of the raids can be considered disappointing. Fuel production was back up to capacity after several weeks. The American raids cost 53 aircraft and the lives of 306 airmen. Another 139 were captured, and 69 were interned in Turkey. Including the injured and wounded, losses amounted to an unacceptable 55%. After the mission, the Americans could press back into service only one-sixth of the original number of aircraft, and technical losses reached 33%. Five airmen were awarded the highest commendation, the Medal of Honour, three of them posthumously. This was unprecedented, as this many of this award was never awarded to this many participants of one mission. In comparison, the Korean War produced four Medal of Honour recipients, and the entire Viet Nam War, thirteen. The Second World War saw 35....

HISTORY

B-24D-CO, s/n 41-11766, „Chug-a-Lug“



B-24D-CO s/n 41-11766, 9th AF, 98th BG, 345th BS, Lecce AB, Italy, Summer, 1944.

This aircraft, commanded by 1st Lt. Leroy B. Morgan, took part on August 1st, 1943, in a raid on Ploesti, in Romania. The 98th BG 'Pyramiders' dispatched 48 Liberators. The return from the Balkan hell that ensued saw only thirteen, one of which was 'Chug-a-Lug'. The remaining aircraft either didn't even make it as far Ploesti, were shot down, or were forced to land at Malta, Sicily, and Cyprus.

Chug-A-Lug returned from Ploesti a further two times. After surviving 105 combat missions, it was called back to the States on July 19th, 1944, where it went on a War Bond Tour. The typical USAF desert scheme consisted of Sand over Neutral Gray. Not typical was the placement of the nation-

nal insignia on the tops of both wings. The fuselage marking went through an interesting evolution. After June, this marking was complemented by white bars on the sides, and received a red outline as per orders, with this being replaced by blue after two months. On black and white period photographs, there is a contrast between the fresh blue outline and the blue of the insignia, caused by the heavy climatic weathering on the paints.

The renderings of the babes on both sides of the nose were inspired, as was the norm, by so-called 'pin-up' girls. Pin-up girls perforated Anglo-American culture from the nineteenth century. Typically, this took the form of models and actresses in provocative clothing and poses. Specifically, the extremely well rendered drawings of Alberto Vargas,

George Petty and Gil Elvgren were very popular inspirations. The term 'pin-up' comes from the fact that many of these drawings and paintings were included in centrefolds and calendars and were often pinned up on a wall.



- Lt. Reuben J. Weltha crew at nose of their distinguished B-24D „Chug-A-Lug“ after returning from her last 105th combat mission (Manduria base, Italy).

Inflight photo of B-24D, s/n 41-11766 „Chug-A-Lug“ during return from her last 105th mission. Among of them there were also three „trips“ over Ploesti.

B-24D-CO, s/n 41-11613, „The Blue Streak“



B-24D-CO, s/n 41-11613, 9th AF, 376th BG, 514th BS, San Pancrazio AB, Italy, February, 1944.

This aircraft was delivered to the USAAF on March 29, 1942, when it arrived at Mobile Air Depot. Less than a month later, on April 22, it was assigned to the HALPRO Unit (Halverson Provisional Unit). This unit was commanded by Col. Harry A. Halverson and was destined for the 10th AF for combat over China. Ultimately, this didn't happen, and the aircraft remained in Northern Africa. HALPRO transferred to the 376th Bombardment Group 'Liberandos' in October, 1942. The aircraft car-

ried several names, the first being 'Florence Jo Jo', followed by 'Teggie Ann' and finally 'The Blue Streak'. This aircraft flew a total of 110 missions with the 376th BG. It was then decided to include it in the War Bond Tour. The aircraft was sent back to the States, where, commanded by Capt. Ralph Thompson, it began its participation in the tour in February, 1944. In preparation for the tour, and during the tour itself, the aircraft underwent minor appearance changes. The basis of the decorations was the mission markers, and the map that documented the area of operations, and included

crew names, groundcrew names, and their awards. With the names on the left side of the rear of the aircraft, there are ribbons corresponding to the Distinguished Flying Cross awards, Legion of Merit, Air Medal, and others. Multiple awards were represented by an Oak Leaf Cluster. The Olive Drab color on the top was combined with Deep Sky Blue on the lower surfaces, and by the time of the tour, it was clear that this airplane had a history. Freshly painted areas were evident, indicated on black and white photographs as darker fields. The scheme on this aircraft came about in an interesting way. It was

originally built for Great Britain, where the RAF planned to employ it as a high altitude bomber, for which the Deep Sky Blue was considered well suited. Ultimately, it didn't get to Britain, and found its way into the services of the United States instead. The aircraft that went this route were dubbed the 'Blue Bellies'. It is possible that this fact also had a bearing on the name 'The Blue Streak'.



B-24D-15-CO, s/n 41-24047 „Moby Dick“



B-24D-15-CO, s/n 41-24047, 5th AF, 90th BG, 320th BS, Southwest Pacific

This Liberator was delivered to the USAAF on October 13th, 1942. By the 23rd of November, it was involved in missions in the SWPTO. The aircraft laboured for more than one hundred missions, and was selected to participate in the War Bond Tour, which it commenced in October, 1943. After that, Moby Dick was then converted to a TB-24D transport. This aircraft was often flown with the 90th BG by a crew led by Major Paul W. Gottke. Gottke flew 57 missions, most in 'Moby Dick'.

The skull and cross-bombs on the tail surface became the unit marking for the 90th Bombardment Group 'Jolly Rogers' from mid-1943. From Septem-

ber, 1943, to the middle of 1944, all aircraft had them in black and white. After that, the base color was changed to that of individual squadrons, and the 320th BS had the white skull and bombs on red background. It was interesting to note the origin of this marking. It had to do with the name of the CO of the 90th BG, Col. Arthur Rogers (CO from July 11th, 1943). Keeping with the pirate theme was not much of a leap from that. The author of the rendition was Sgt. Leonard H. Baer, and was first applied to the CO's aircraft. The sharkmouth was applied to several aircraft of the 520th BS. The name 'Moby Dick' was not only carried by this aircraft, but all of the 520th BS. The outline was intended to be broken up by the application of me-

dium green fields on the wings and tail surfaces.

Liberators reached the 90th BG at the beginning of its existence. The unit formed on January 28th, 1942 at Key Field in Mississippi, and after training moved to Hickham Field on Oahu, in the Hawaiian Islands. The unit command at this time was not pleased with the Liberators, and there was a plan to even fit the Convair A-6 turrets. Besides that, requests were made to equip with the B-17 instead. The unit remained equipped with the B-24, with which the 90th BG came to the Southwest Pacific through Australia, Papua New Guinea and into the Philippines.

B-24D-20-CO, s/n 41-24198, „The Vulgar Virgin“



B-24D-20-CO, s/n 41-24198, commanded by Capt. Wallace Taylor, 98th BG, 244th BS, Northern Africa, summer, 1943.

One of the most famous raids conducted during the Second World War were those aimed at the oil refineries of Ploesti in Romania on August 1st, 1943. This aerial operation codenamed 'Tidal Wave' was intended to take out of commission the oil refine-

ry that at the time accounted for about 35% of all output. Photographs of Liberators over the burning refinery circulated around the globe, and the four-engine, twin tailed bomber became the symbol of the hell descending down on the Romanian facility.

One aircraft that did not make it back from the raid was 'The Vulgar Virgin'. The aircraft was brought down by a direct hit from AAA fire, and the only

survivor was the Captain, Wallace Taylor. The B-24 was a member of an eight ship section. Three were turned back by various technical problems, and the five remaining planes approached the target using the local rail line for guidance. This was anticipated by the Germans, and they were able to display their lethality by destroying all five aircraft of the incoming flight.

HISTORY

The aircraft was camouflaged in the typical scheme for this theatre of operations, comprising Sand (or Desert Pink) and Neutral Gray. The sand color was applied over the original Olive Drab, and this layer is lightly visible in sections. The aircraft carried earlier style of national marking, used up to June, 1943.

With the passage of time, it has been difficult to ascertain the original inspiration for the name, but the female likeness on the front hails from Esquire magazine from November, 1941. It's author was American painter named George Brown Petty IV. Besides those of Alberto Vargas, his portraits appeared on bombers as well (including in Kit No. 2110, 'Liberating Beauties'), and was one of the best known 'Pin-Up' artists. Esquire Magazine published his work from 1933 to 1956. His signature feature was the long legs of his subjects. Apparently, the most famous of his inspirations resulted in the noseart of the B-17 Flying Fortress, the 'Memphis Belle'.



The Vulgar Virgin with her ground crew and one of the flying crews that ride her into combats.

Big thanks goes to Pavel Turk for selecting Liberators in both Limited Editions „Liberating Beauties“ and „Mission Centenarians“, as well as for extensive help with reconstruction of colors and history description of the aircraft.

All photos are used courtesy of US National Archives via www.footnote.com



BUY B-24D 1/72 LIMITED EDITION



Su-22M4 1/48

BUILT



This Limited edition kit is out of sale (Cat.No. 1149).

Built by Filip Kosata, 14 y.o., KPM Sázava.



MiG-21 MF

Camo: MiG-21M, 4th Fighter Squadron, Pardubice Air Base, Czechoslovakia, June, 1989

Built by Jan Petr, 15 y.o.



Built from Limited edition kit 1153X 1/48.

BUY MiG-21MF 1/48



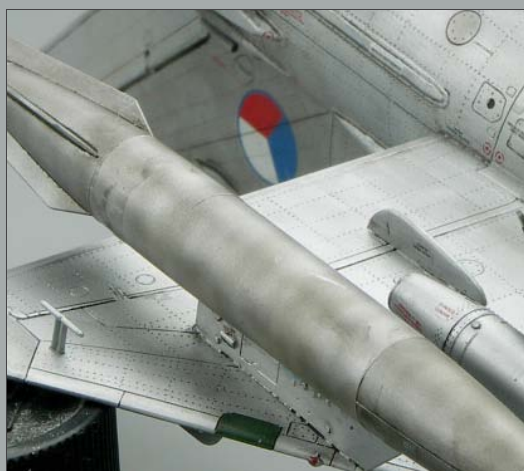

Photos provided by Jan Petr.

BUILT

ENGINE DB 601

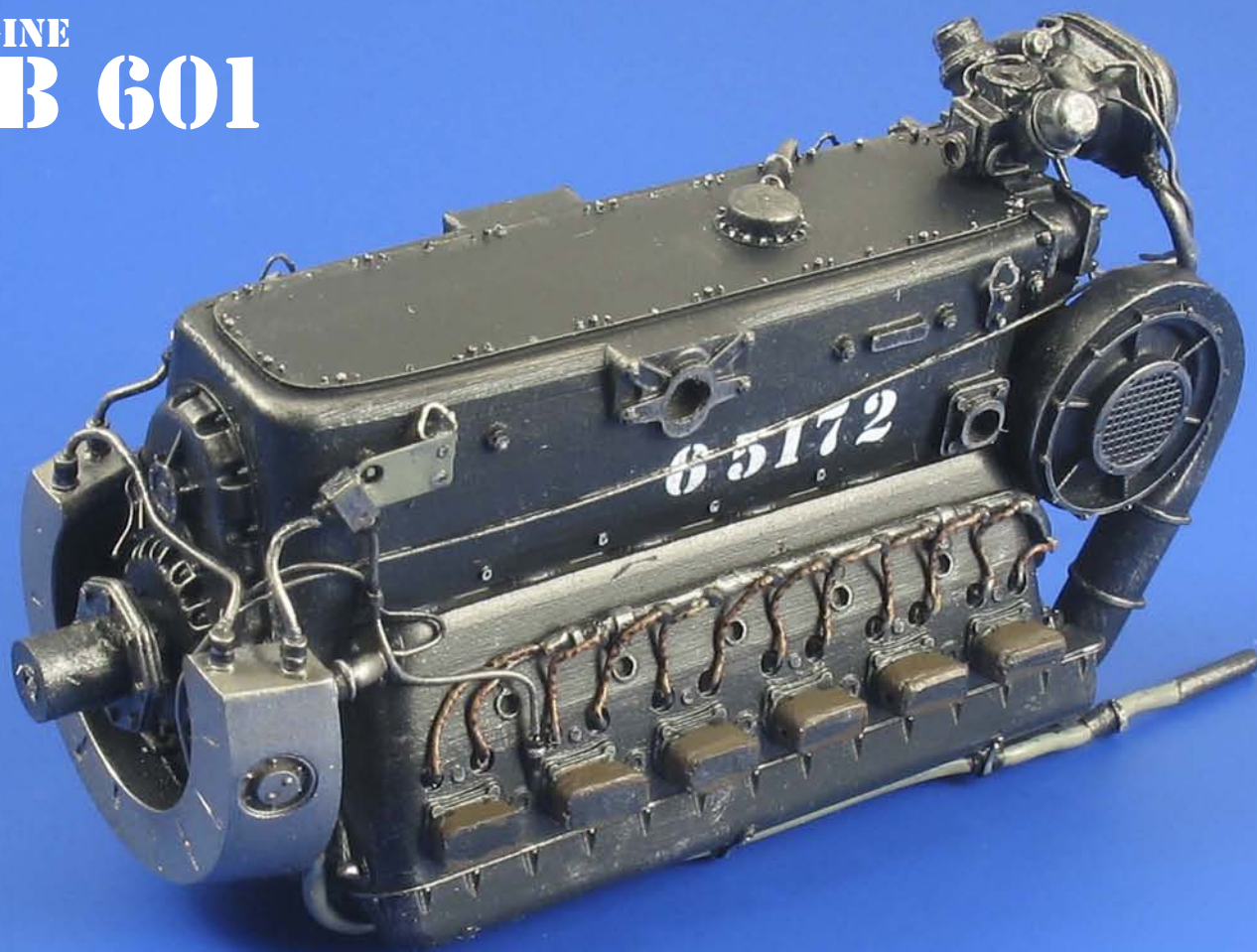

Built Brassin engine DB 601 1/32
Cat.No. 632003. Built and photo by Zdenek Sebesta.

BUY 632003 DB 601 engine 1/32

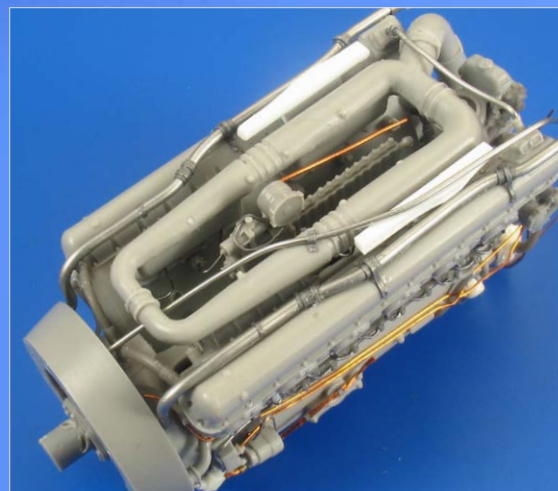
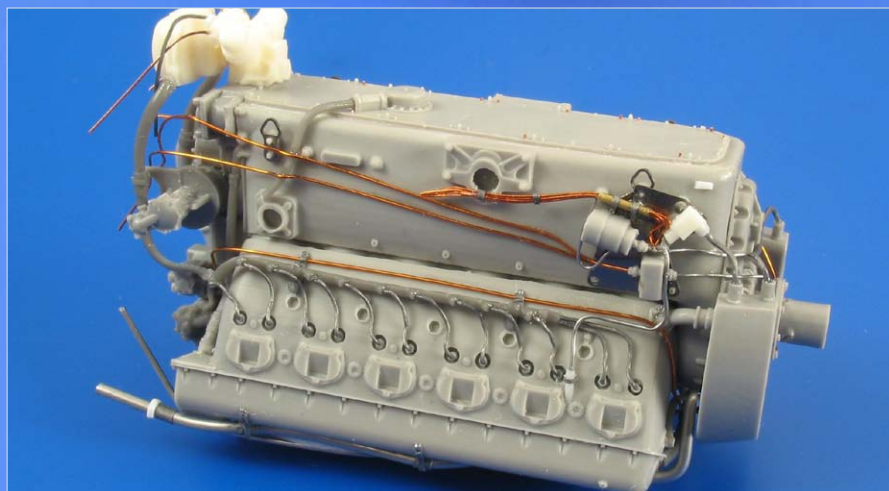

Bf 109E-7 TROP

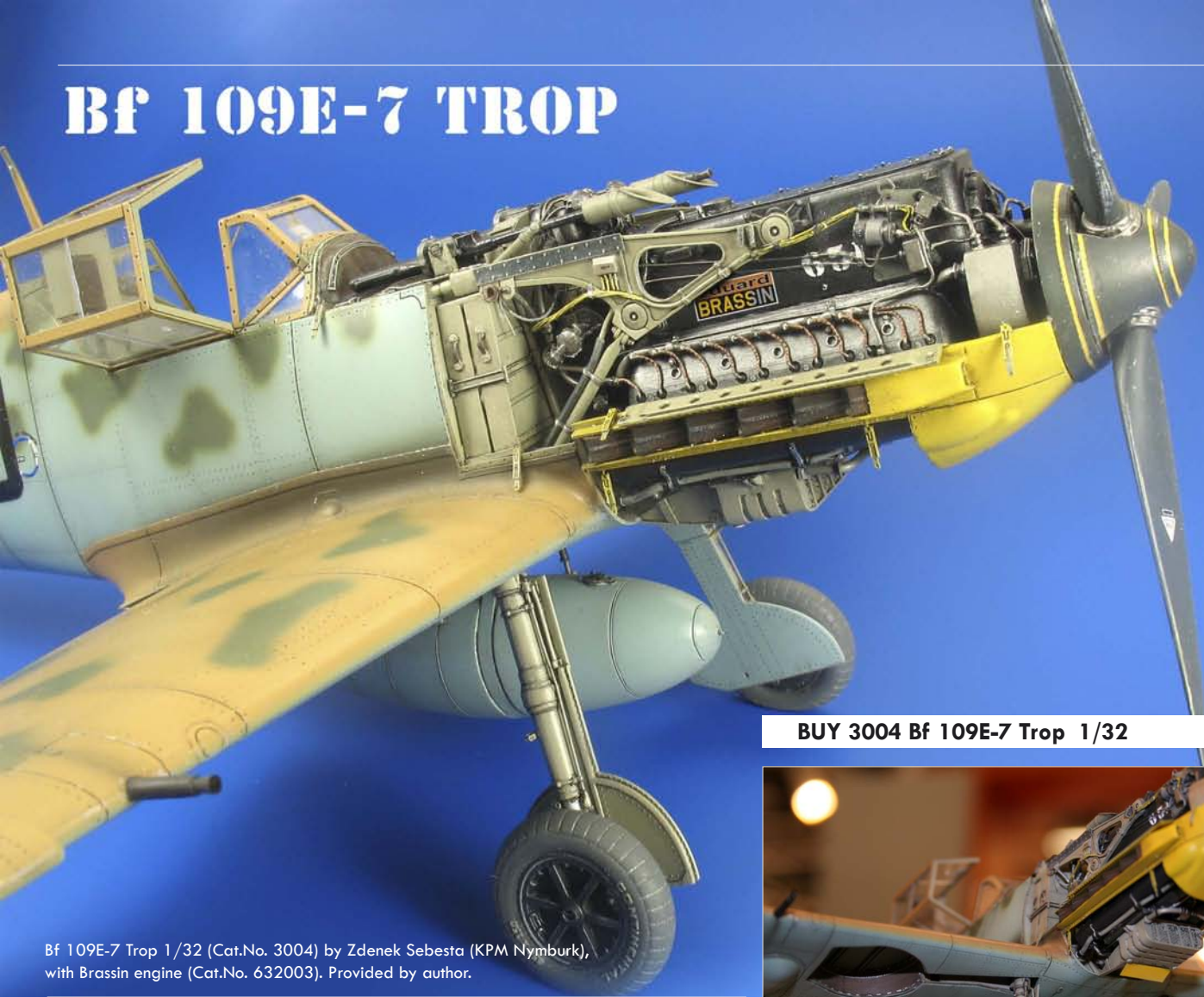

BUY 3004 Bf 109E-7 Trop 1/32

Bf 109E-7 Trop 1/32 (Cat.No. 3004) by Zdenek Sebesta (KPM Nymburk), with Brassin engine (Cat.No. 632003). Provided by author.



Other Bf 109E available [HERE](#)

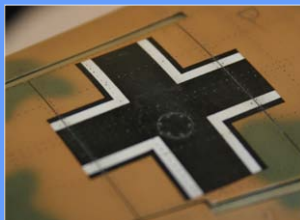

Brassin sets for Bf 109E 1/32:

BUY

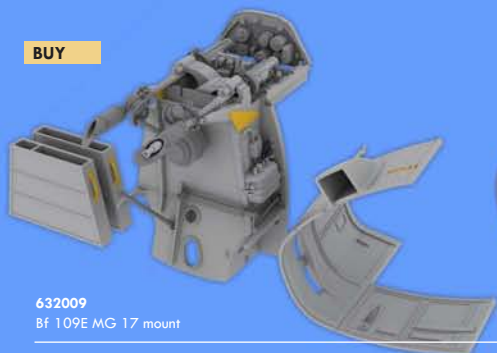

632009
Bf 109E MG 17 mount

BUY

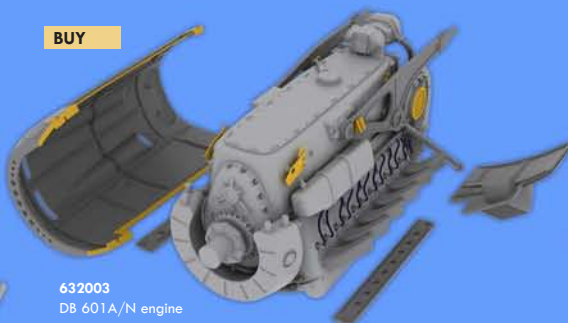

632003
DB 601A/N engine

BUY

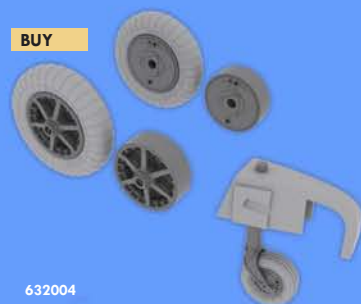

632004
Bf 109E wheels



During weekend of 14th – 15th April 2011 we have attended 15th annual „Model Show Mosonmagyaróvár“ in Hungary. There was lot of what to see.



Shop floor of smaller vendors at the hall of the local university.



Cash desk of our "shop" was instantly very busy...



A few of displayed models from Eduard production. Avia B-534 1/48.





Great diorama with Eduard's Hellcat 1/48.

↓ Outdoor display of WWII vehicles, particularly German Hetzer and Soviet ZIL with Katjusha.



Fw 190D-9 1/48.



Ha..?

Beautifully build Eduard Fokker Dr. I 1/48.



Our friend and cooperator, aviation artist Pavel Rampir (with his wife) at stand. You may have seen Pavel's art for example as boxarts for Eduard scale figures or in publication released as part of the Limited Edition P-39 Airacobra over New Guinea.





MiG-21 bis

Dimensional check of MiG-21BIS in Berlin-Gatow

To verify or negative the mind about the different nose of the MiG-21BIS, we made a quick trip to Berlin. We were four, MiG-21 chief designer Lada Jonas, designer Standa Archman (he designed OEFFAG 153/253 or Fw190D in past months), pre-production adjustment manager Mirek Horcicka (he co-ordinates decal, photo etch, box, and instruction sheet design for the kit production) and Vladimir Sulc, our boss. Thanks Andreas Beck and Dr.Jürgen Willisch, we had nice occasion to study MiG-21BIS directly in Luftwaffenmuseum Berlin-Gatow. After three hours of our study and dimensional check, we know that the nose of the BIS is really wider about 22 mm on the diameter of the fuselage after the front steel intake ring than MF. It means some 0,4 wider intake requested on the 1/48th scale kit, which is nothing terrible, but, unfortunately, the shape of the first 15 cm nose segment is also different. It means that we will design new fuselage, although there is no other change on the rest of fuselage, except the rear top of the back. It is an amazing result, isn't it?





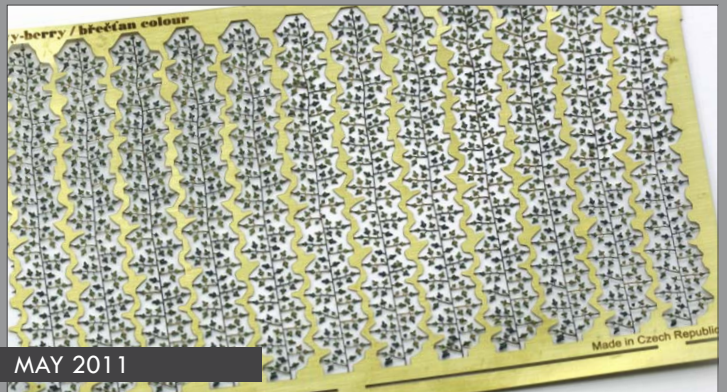

PHOTO-ETCHED

36152 Wild Flowers



36161 Ivy-berry/brectan colour



36152 Sunflowers/slunečnice



RELEASES:

- Grape-vine (June 2011)
- Reeds
- Palms
- Fauna
- For indoor diorama - dishes and food

E-bunny Postcards

Available from June 2011 within Eduard scale kits

E-bunnies are spreading joy amongst modelers! From June 2011, E-bunny Postcards will be available to modelers who purchased Eduard scale kit. We will be adding one E-bunny Postcard into every other scale kit released in June 2011 and further.

The question is...

Which one will be yours?



E-Bunny Postcards are printed with regard for the environment on eco-friendly, recycled paper.

MiG-21 MF BRASSIN INTERIOR!

...IN PREPARATION

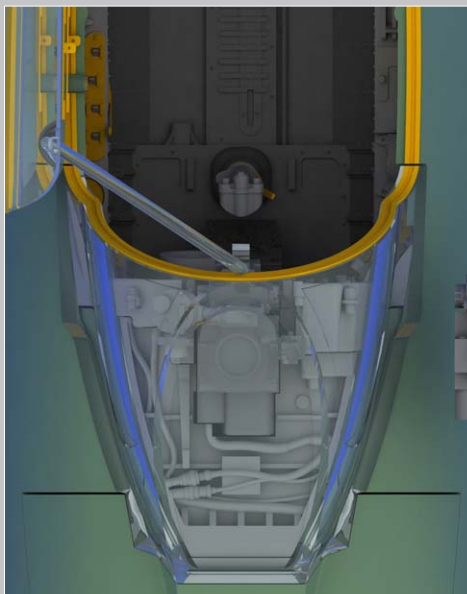
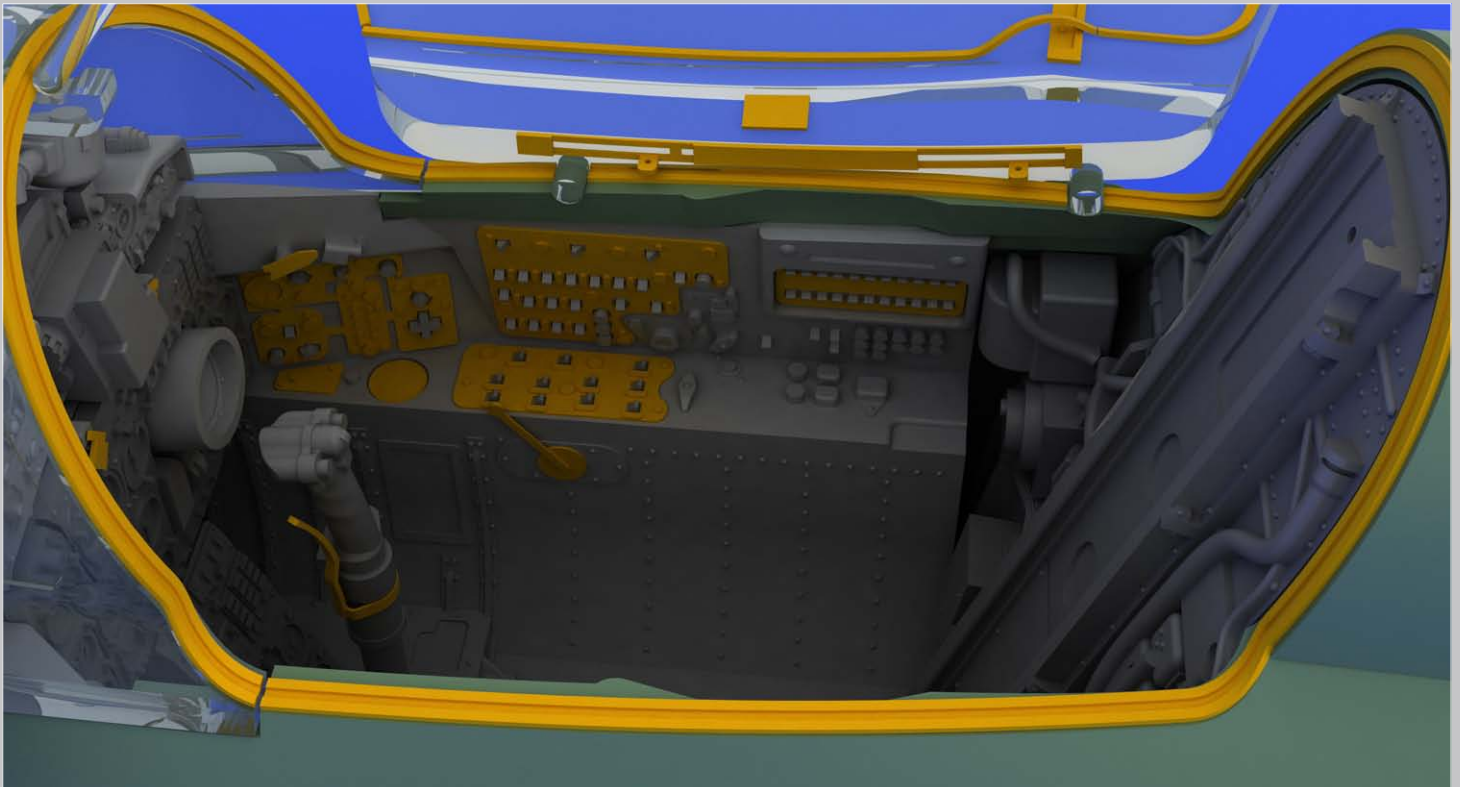

What about this Brassin set?

MiG-21 cockpit interior for our kits in 1/48 will be one of the future releases (expected during Summer 2011). First will come interiors for MiG-21MF in early and late versions (Cat. Nos. 648035 and 648036), variants for MiG-21SMT/MT will follow.

This first photo shows control panel and other front interior instruments. The green parts represents plastic kit, grey is resin and gold color represents photo-etched parts (mostly colored). There will be alternate gun-sight. Point of interest may be also the fact, that this set will contain clear resin parts for accurate reproduction of the gun-sight reflective glass.

Check more photos with comments [here](#).

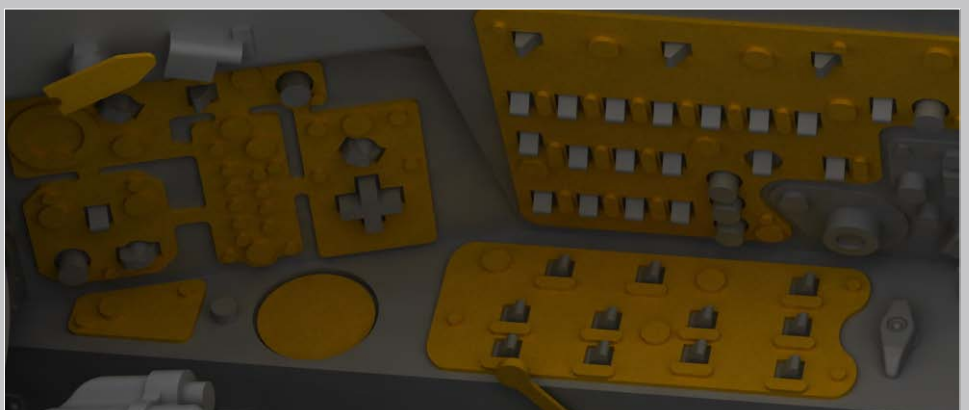

KITS

JUNE

8290

Lysander MK.III
1/48 ProfiPACK

1155

Fw 190A JG-54 Grünherz Dual Combo
1/48 Limited edition

84106

Fw 190D-13
1/48 Weekend



BIG ED

JUNE

- | | | | | |
|---------|-------------------|------|------|------------|
| BIG3301 | Su-27UB | 1/32 | 1/32 | Trumpeter |
| BIG4948 | Sea King AEW Mk.2 | 1/48 | | Hasegawa |
| BIG4949 | Bf 110D | 1/48 | 1/48 | Dragon |
| BIG7266 | Rafale B | 1/72 | 1/72 | Hobby Boss |

Su-27UB



Su-27UB



eduard BRASSIN

JUNE

648029
AIM-9M/L Sidewinder
1/48

648032
F-16 radar early
1/48 Tamiya

648034
MiG-29 seat late
1/48 Academy

648029



648032

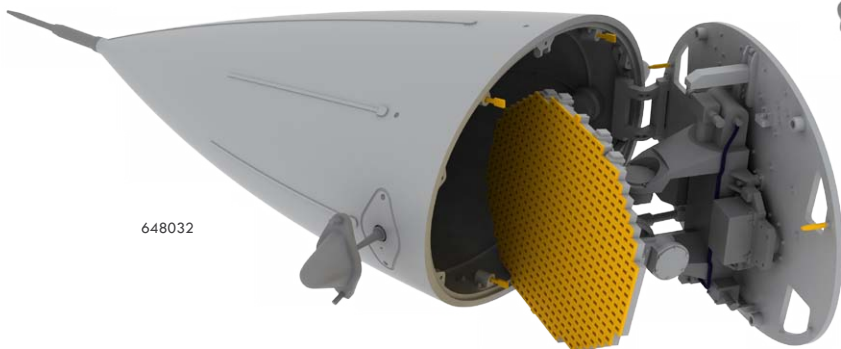

648034



PHOTO-ETCHED DETAILS

PE-SETS

17521	Life buoy	1/700	
32690	Remove Before Flight - Israel	1/32	
32695	Hawk T1 Mk.53 seatbelts	1/32	Revell
32699	Hawk T1 Mk.53 interior S.A.	1/32	Revell
36140	StuG.III Ausf.F/8	1/35	Dragon 6644
36157	M-7 Mid production deep water fording eq.	1/35	Dragon
36159	Leopard 1A5	1/35	Italeri
36168	Sunflowers/slunečnice	1/35	
36170	Grapevine/vinná réva	1/35	
48697	S-3 bomb bay	1/48	Italeri
48698	S-3 undercarriage	1/48	Italeri
48702	MiG-21MF exterior	1/48	Eduard
49517	Bf 109E-3 S.A.	1/48	Airfix
49551	Su-24M Fencer D interior S.A.	1/48	Trumpeter
49552	Su-24M Fencer D seatbelts	1/48	Trumpeter
49553	RF-5E S.A.	1/48	AFV Club
49556	Mirage 2000D interior S.A.	1/48	Kinetic
49558	Me 262A-1/U4 S.A.	1/48	Hobby Boss
49571	MiG-21MF late interior S.A.	1/48	Eduard

53048	Prinz Eugen	1/350	Trumpeter
53060	Prinz Eugen railings	1/350	Trumpeter
72513	Mi-24V Hind E exterior	1/72	Zvezda
73368	Mi-24V Hind E interior S.A.	1/72	Zvezda
73384	Sea Harrier FRS.1 S.A.	1/72	Airfix
99026	Railings 45' 2 bars short	1/700	
99027	Railings 45' 2 bars long	1/350	

ZOOMS

33086	Hawk T1 Mk.53 interior S.A.	1/32	Revell
FE517	Bf 109E-3 interior S.A.	1/48	Airfix
FE551	Su-24M Fencer D interior S.A.	1/48	Trumpeter
FE553	RF-5E S.A.	1/48	AFV Club
FE556	Mirage 2000D interior S.A.	1/48	Kinetic
FE558	Me 262A-1/U4 interior S.A.	1/48	Hobby Boss
FE569	MiG-21MF early interior S.A.	1/48	Eduard
FE571	MiG-21MF late interior S.A.	1/48	Eduard
SS368	Mi-24V Hind E interior S.A.	1/72	Zvezda
SS384	Sea Harrier FRS1 S.A.	1/72	Airfix
TP531	StuG.III Ausf.F/8 interior	1/35	Dragon 6644



48702 MiG-21MF exterior
1/48 Eduard



32695 Hawk T1 Mk.53 seatbelts
1/32 Revell



36140 StuG.III Ausf.F/8
1/35 Dragon 6644

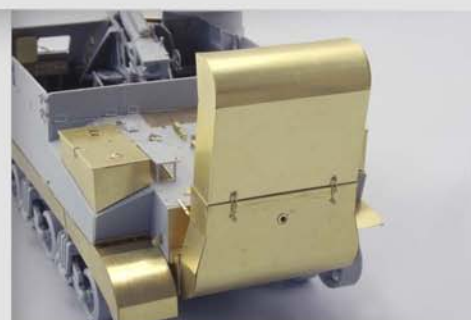

36157 M-7 Mid production deep water fording eq.
1/35 Dragon

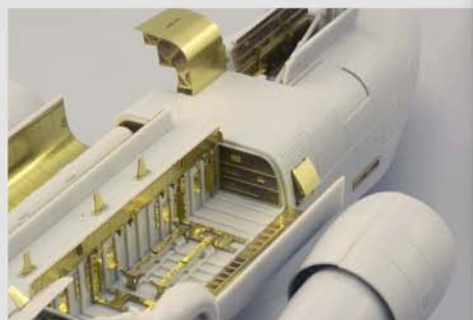

48697 S-3 bomb bay
1/48 Italeri



49551 Su-24M Fencer D interior S.A.
1/48 Trumpeter



53048 Prinz Eugen
1/350 Trumpeter

INTERNATIONAL SCALE KIT EXHIBITION

IPMS
CZECH REPUBLIC

eDay



UNIQUE SHOW FROM THE WORLD OF SCALE PLASTIC KITS, INSPIRATION
FOR CREATIVE KIDS AND PARENTS. COMEBACK OF YOUR CHILDHOOD.

1. 10. 2011
9.00-18.00
SHOPPING CENTER
GALLERY BUTOVICE
PRAGUE

EXHIBITORS AND RESELLERS
OF HUNDREDS OF MODELS

ENTERTAINMENT FOR VISITORS

EASY ACCESSABILITY, FREE PARKING, SNACK-BAR

TUBE  B Radlicka 520/117, Prague 5
STATION NOVE BUTOVICE underground parking lot

GPS: 50°2'50.9"N, 14°21'17.7"E

WWW.EDAY.CZ 



eduard



European get-together for plastic scale modellers and contest exhibition

Junior Plastic Scale Modeller's Championship of the Czech Republic

MODELLBRNO 2011



June 18, 2011, 9:00-17:00

Brno Exhibition Centre, Czech Republic

Exhibition with hundreds of plastic scale model kits • Workshops

Large accompanying programme • Many traders selling model kits and accessories

The very rare and famous „Butch of the Year“ competition in throwing finished models

www.modelbrno.cz

GENERAL PARTNERS AND ORGANIZERS



B | R | N | O | I



GENERAL SPONSORS

AZ Model • Bílek Hobby Kits • Lifecolor.cz • Eduard Model Accessories • junek-R • Modelartikl.cz • MPM Production • Nordland Models • OD Vágnér • Transtech Tooling

SPONSORS

Catering Infinito • CMK • ExtraTECH • Hauler • HpH • Keraservis • MODEL Box • PK Graphica • Reda • Rotschein Airbrush Model Shop • Sklenářství Rosprim
Veletržní výstavní servis • Web Facies • Wingscale CZ

MEDIA PARTNERS

Kagero • Letectví a kosmonautika • Modelář • Rádio Krokodýl • Radio R • Revi • SAM Publications • Super Model • Tamiya Model Magazine International