

A6M3 Zero Type 32

eduard

1/48 Scale Plastic Model Kit

WEEKEND
edition



item # 84191

The Mitsubishi Zero became the symbol of the Japanese air power during WWII. The A6M3 Type 32, introduced by the Japanese Naval Air Force in 1942, was initially considered a new type of aircraft by the Allied forces.

During the 1920s and 1930s the Japanese aircraft industry was oriented towards the production of foreign license-built aircraft. However, the armed forces, especially the Navy with regard to the specifics of the Chinese and Pacific battlefields, came up with requirements that foreign aircraft designs did not offer. Hence, Mitsubishi Heavy Industries developed the Type 96 naval fighter aircraft, better known as the A5M Claude. The head of the design team was a young Japanese engineer, Jirō Horikoshi. With an engine that lacked some power, he managed to design a light and fast fighter with a fixed landing gear, which had no comparison in the world regarding maximum speed. In October 1937, Mitsubishi and Nakajima were approached to develop prototype 12-shi Carrier-based Fighter. The requirements were so extreme, and in some cases contradictory, that the two design teams investigated whether they could be less stringent. Nakajima eventually withdrew from the project, while the criteria for the prototype were even raised based on experience on the Chinese battlefield.

In the end, Horikoshi's team managed to meet the technical specifications, not only thanks to the aerodynamic design and a new type of light alloy used for the aircraft's skin, but also thanks to the Nakajima Sakae 11 engine. During the flight tests, the wing surface suffered cracking during overload, and aileron control during high-speed maneuvers had also to be addressed. The new fighter had powerful armament of two cannons and two machine guns, extremely long range (over 1,800 km) and excellent maneuverability. The new fighter reached top speed of 533 km/h at an altitude of 4,550 m. However, it lacked armor and other protective features and the structural speed limit was only 600 km/h.

The new aircraft entered service in 1940 powered by 940 hp engine Sakae 12 and received the official designation Rei shiki Kanjō sentōki (Type 0 carrier fighter), with the "zero" being derived from the imperial year 2600 (1940). Japanese pilots usually abbreviated it as Rei-Sen. That was also the origin of the name Zero, often used by Allied pilots instead of the official code name, derived from the male name Zeke.

As part of the Navy's system, the new aircraft was given the designation A6M, where A6 meant that it was the sixth type of carrier fighter to enter service, and M stood for the Mitsubishi company name. Zeros, specifically the A6M2 Type 11, had been successfully deployed on the Chinese battlefield since the summer of 1940, but their existence eluded Western intelligence because no one wanted to believe reports from China that suggested the Japanese had a world-class fighter.

Further development

Further modifications to its design were made during 1941, creating the A6M2 Type 21. Total of 740 A6M2 aircraft were produced by Mitsubishi by June 1942 with additional 800 delivered by Nakajima by February 1944. The gun armament was improved and variants with magazines for up to 150 rounds could be used on the Type 21.

After the Allied landings on Guadalcanal, the IJN fighter units came up with a request for a Zero with the Sakae 21 engine, but with the range comparable to A6M2. Designers at Mitsubishi modified the wing including design of fuel tanks. The wing looked similar to the one of Type 21, but the range was even 100 miles longer. This version was designated A6M3 Type 22, the extended gun barrels planes were designated Type 22a.

Another version was the Type 52 with shortened wing-span. Production began in early 1944 and Type 52 was very similar to the Type 22a. Soon the exhaust system was modified to help increase the speed of the aircraft. The Type 52a had enlarged cannons ammunition supply of 125 rounds per weapon. The Type 52b saw the installation of a 13.2 mm machine gun on the right side of the fuselage. For the Type 52c, two 13.2 mm machine guns were fitted in the wing and the 7.7 mm machine gun on the left side of the fuselage was deleted. Eight racks for small caliber bombs or rockets were added to the wing. For night-fighting purposes, a forward-firing cannon in the fuselage behind the cockpit was installed in some Zeros, designated as A6M5-S. In total, Mitsubishi and Nakajima produced more than 5,000 A6M5s.

The last combat-deployed variant of the Zero was an aircraft with a reinforced structure for dive bomber purpose (Type 62). Later, the A6M7 was equipped with the Sakae 31 engine producing 1,130 hp. This fighter-bomber variant was designated as Type 63.

Several hundred aircraft were also modified from the A6M2 Zero Type 21 and A6M5 Type 52 to the two-seaters A6M2-K and A6M5-K, produced from January 1943 and May 1944 respectively.

The kit: A6M3 Zero Type 32

In 1942, Mitsubishi started mass-production of Zeros with a two-stage compressor Sakae 21 engine, delivering up to 1,130 hp. The heavier engine required modification of the engine cowling and also fuselage had to be shortened as well as the wingspan. The modified version was designated A6M3 Type 32. The speed limit was raised but the range was reduced, and 340 examples were produced from June to December 1942. The Allies at first believed that this was a new type of fighter. Therefore, they gave it a separate codename Hap, later changed to Hamp.

The Zero Type 32 was put into service on several aircraft carriers in the second half of 1942, but did not stay in that role for long. The backbone of the carrier force continued to be the Zero Type 21, gradually supplemented by the Type 22 and later the 52.

The main areas where the Zero Type 32 was deployed from mid-1942 onwards were New Guinea, Indonesia and New Britain. Because of their shorter range, these aircraft were used primarily for airfield defense, bomber interception and, where possible, escort flights. Allied airmen encountered them over northwestern Australia, during the fighting over the Solomon Islands and during the raids on Rabaul.

ATTENTION



UPOZORNĚNÍ



ACHTUNG



ATTENTION



注意



Carefully read instruction sheet before assembling. When you use glue or paint, do not use near open flame and use in well ventilated room. Keep out of reach of small children. Children must not be allowed to suck any part, or pull vinyl bag over the head.



Před započítím stavby si pečlivě prostudujte stavební návod. Při používání barev a lepidel pracujte v dobře větrané místnosti. Lepidla ani barvy nepoužívejte v blízkosti otevřeného ohně. Model není určen malým dětem, mohlo by dojít k požití drobných dílů.

INSTRUCTION SIGNS * INSTR. SYMBOLS * INSTRUKTION SINNBILDEN * SYMBOLES * 記号の説明

OPTIONAL
VOLBABEND
OHNOUTSAND
BROUSITOPEN HOLE
VYVRTAT OTVORSYMETRICAL ASSEMBLY
SYMETRICKÁ MONTÁŽREMOVE
ODŘÍZNOUTREVERSE SIDE
OTOČITAPPLY EDUARD MASK
AND PAINT
POUŽÍT EDUARD MASK
NABARVIT

PARTS



DÍLY



TEILE



PIÈCES



部品

PLASTIC PARTS

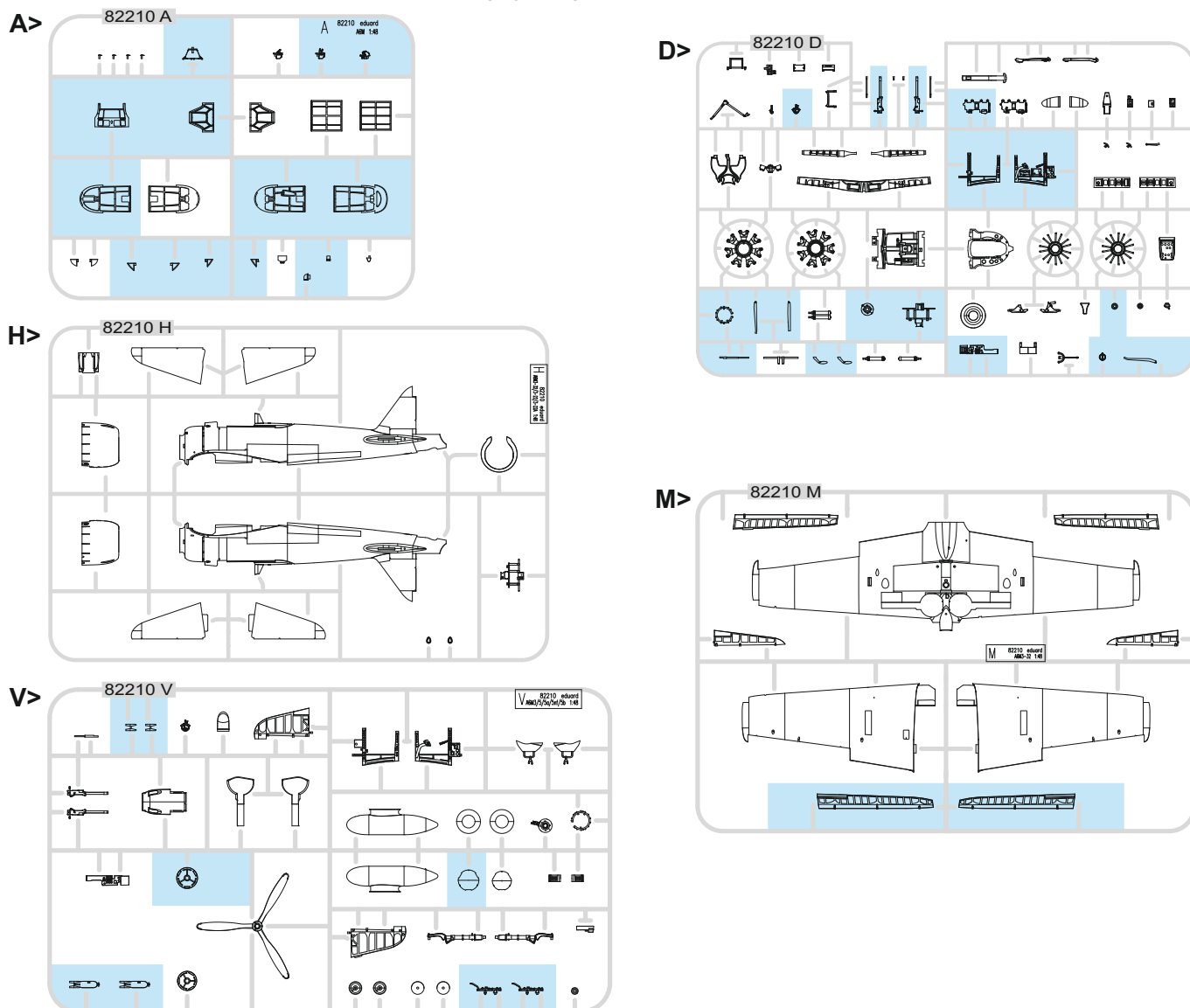

-Parts not for use. -Teile werden nicht verwendet. -Pièces à ne pas utiliser. -Tyto díly nepoužívejte při stavbě. - 使用しない部品

COLOURS



BARVY



FARBEN



PEINTURE



色

GSI Creos (GUNZE)		
AQUEOUS	Mr.COLOR	
H2	C2	BLACK
H8	C8	SILVER
H11	C62	FLAT WHITE
H12	C33	FLAT BLACK
H24	C58	ORANGE YELLOW
H25	C34	SKY BLUE
H47	C41	RED BROWN
H58	C351	INTERIOR GREEN
H63	C57	METALLIC BLUE GREEN
H70	C60	GRAY
H77	C137	TIRE BLACK
H90	C47	CLEAR RED
H93	C50	CLEAR BLUE

GSI Creos (GUNZE)		
AQUEOUS	Mr.COLOR	
H336	C336	HEMP
H417	C117	RLM76 LIGHT BLUE
	C124	DARK GREEN
	C125	COWLING COLOR
	C129	LIGHT GREEN
	C130	DARK GREEN
	C131	RED BROWN
Mr.METAL COLOR		
MC214		DARK IRON
MC218		ALUMINIUM
MC219		BRASS
Mr.COLOR SUPER METALLIC		
SM201		SUPER FINE SILVER

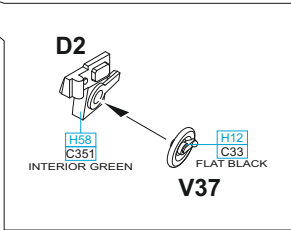
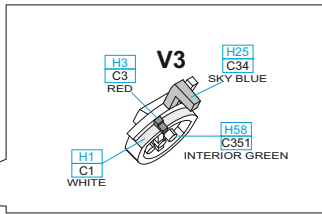
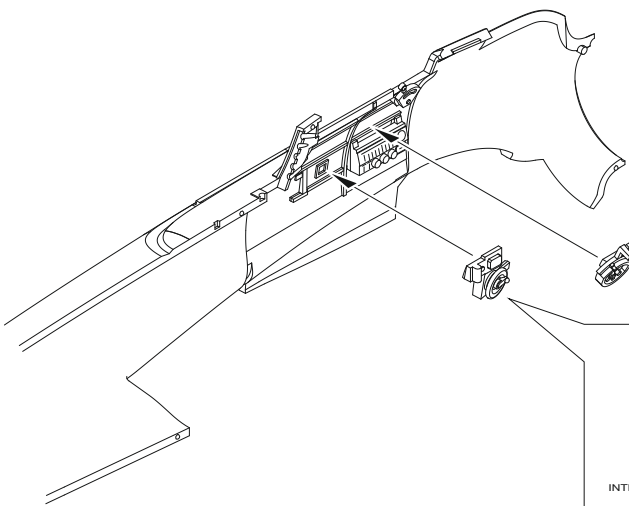
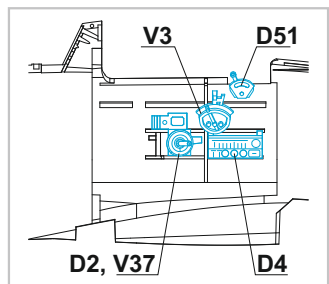
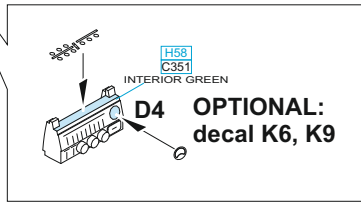
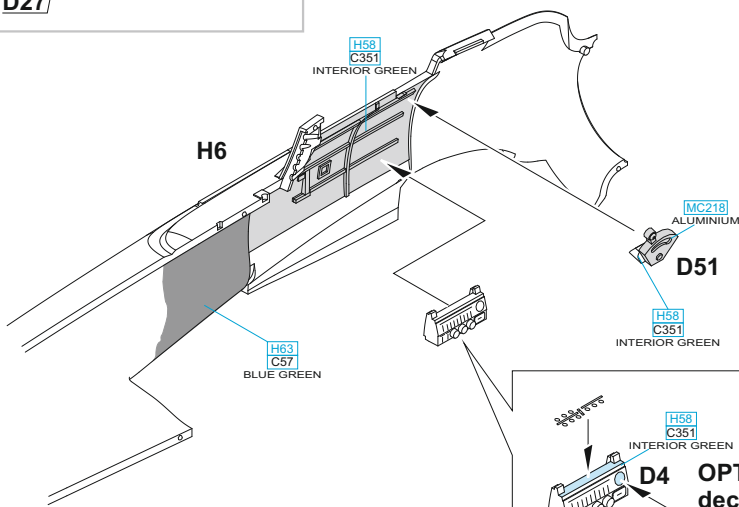
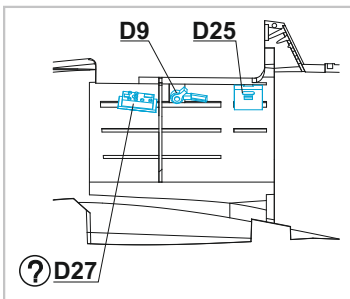
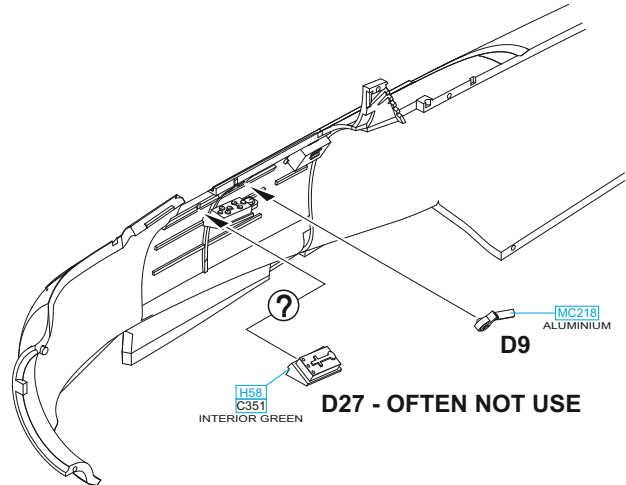
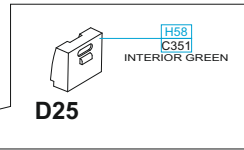
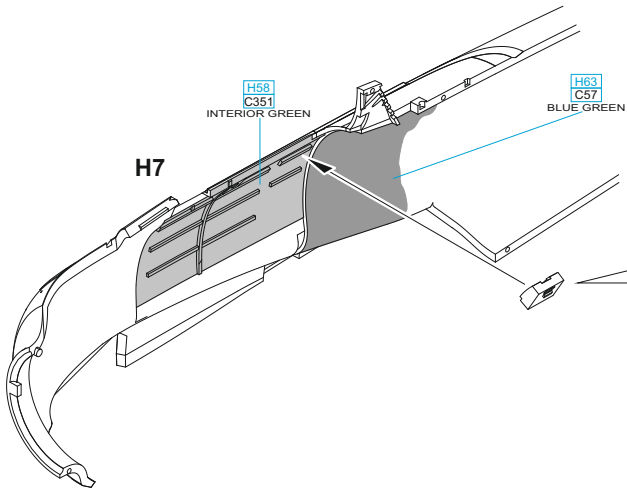

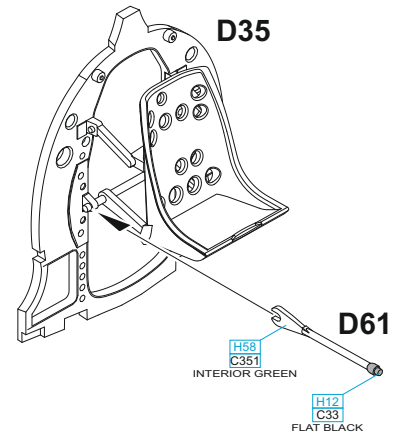
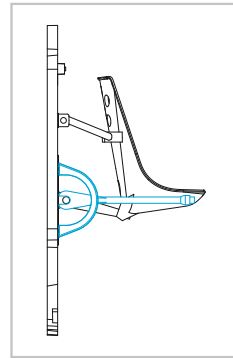
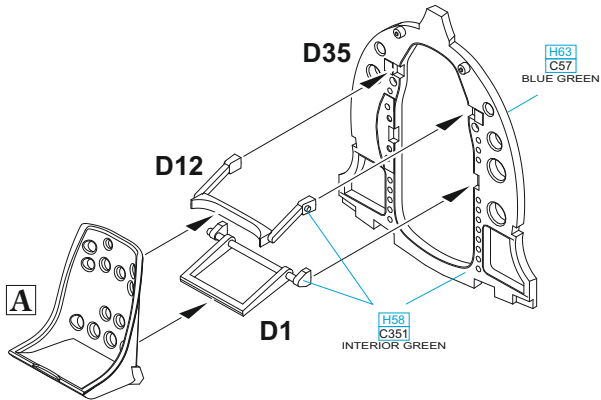
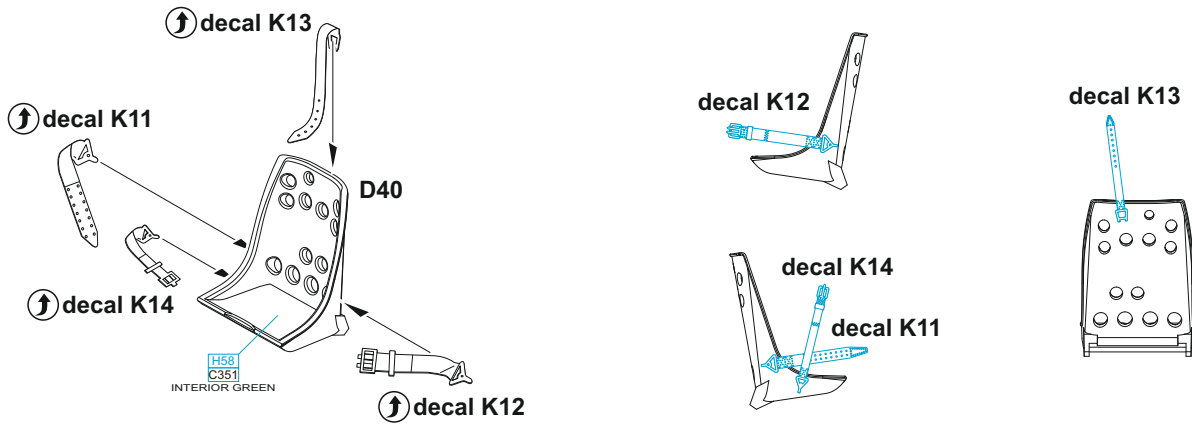
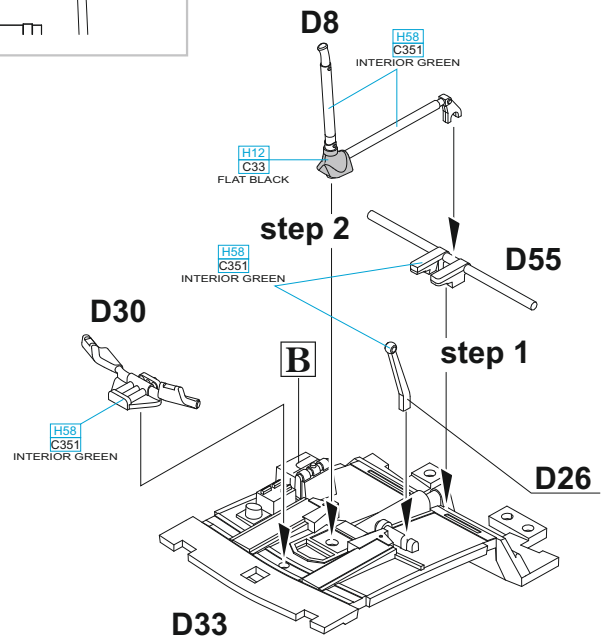
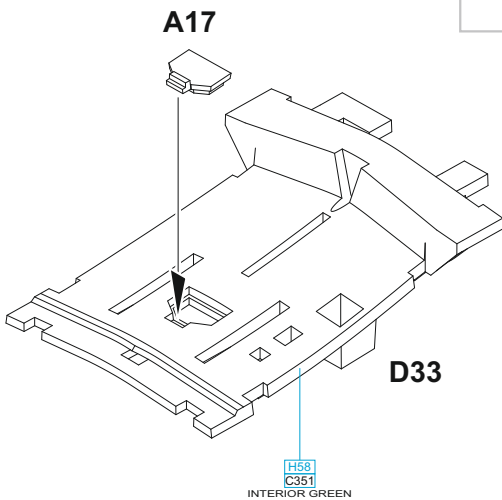
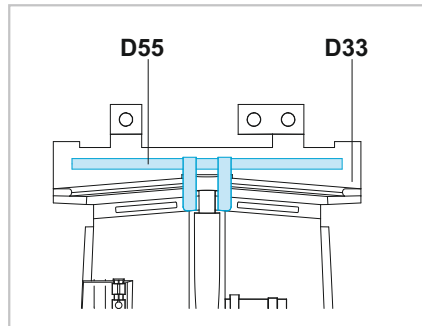
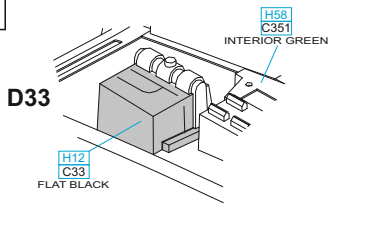
A**B**

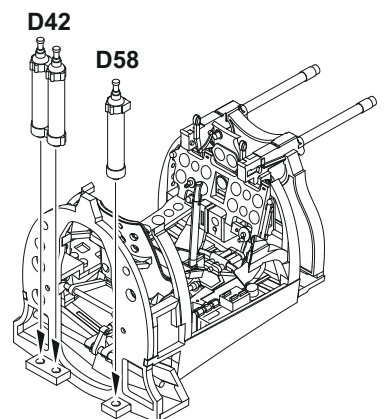
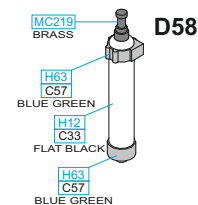
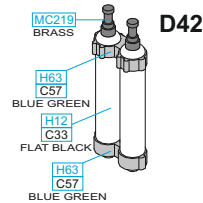
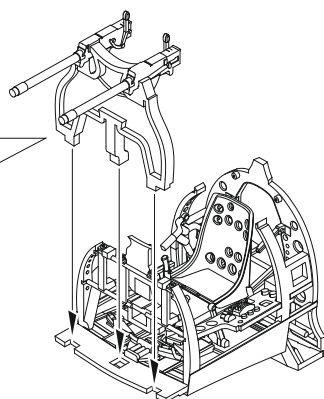
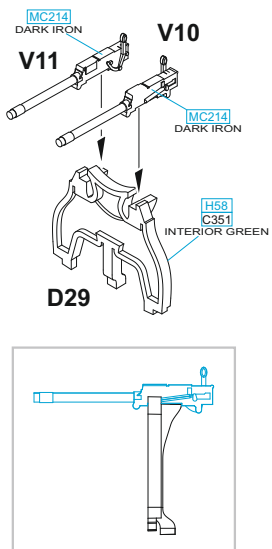
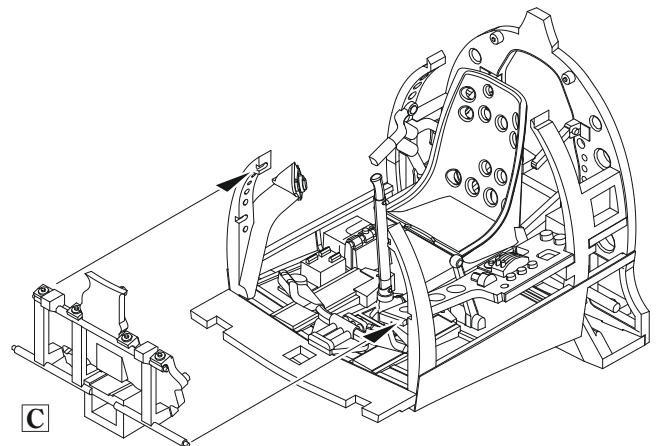
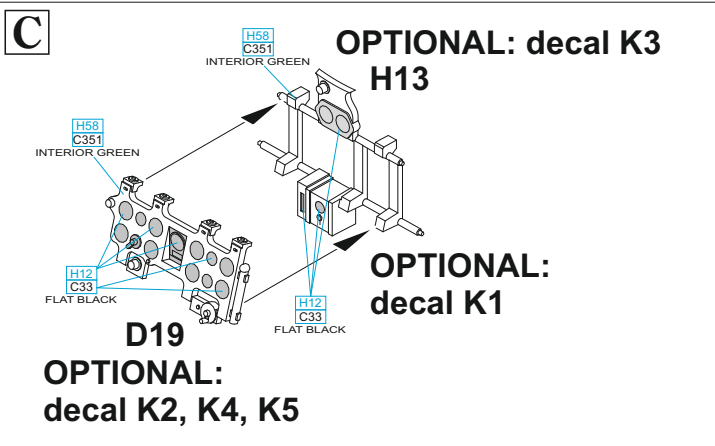
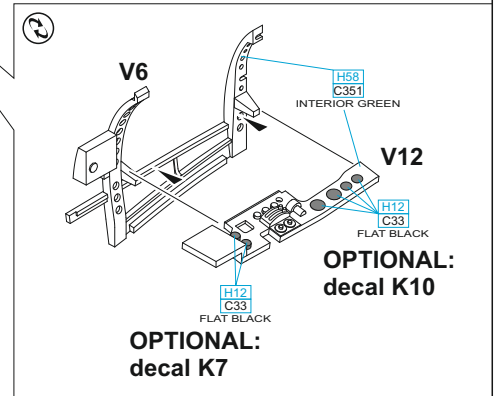
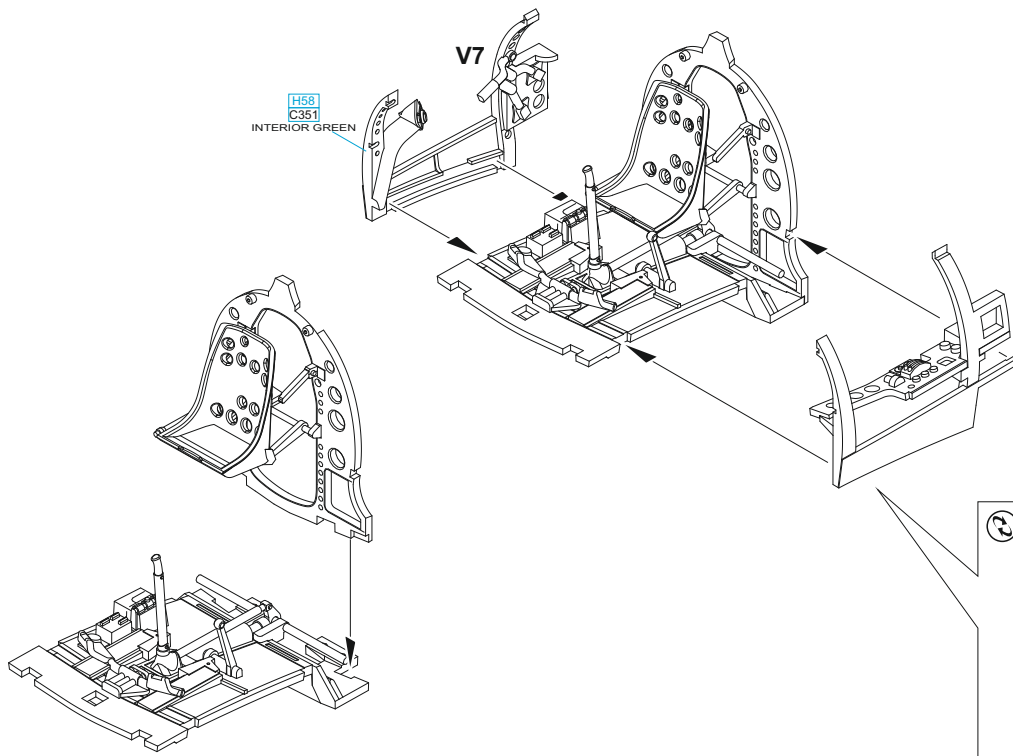

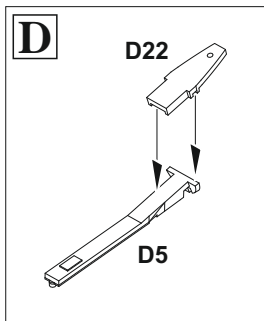

V5 - MARKING **B**
V27 - MARKINGS **A, C, D**

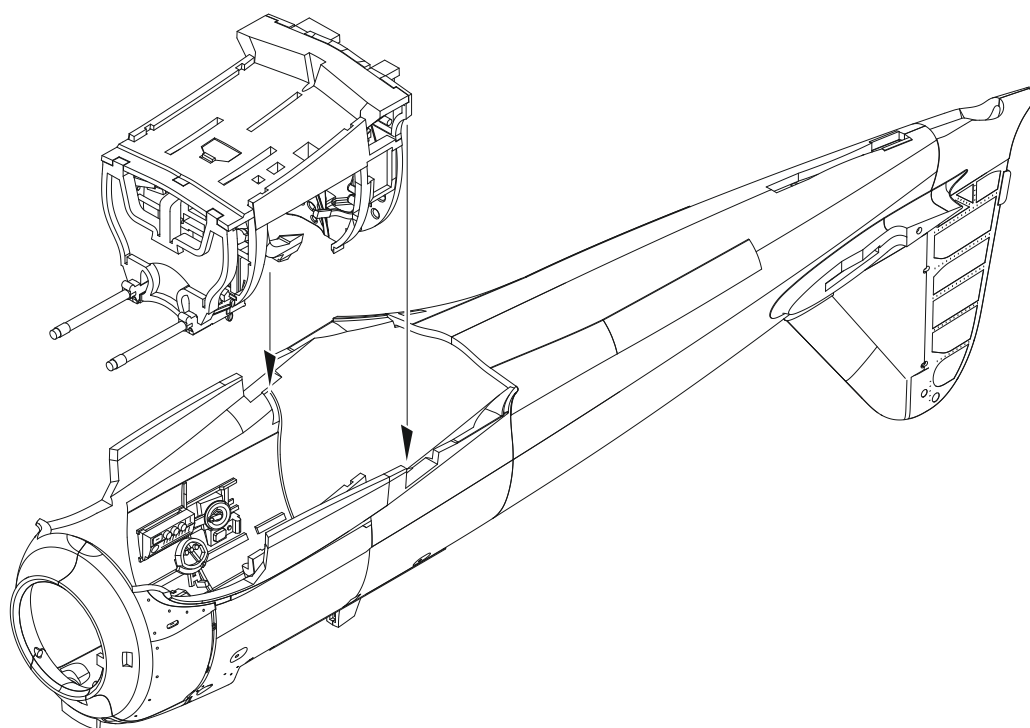
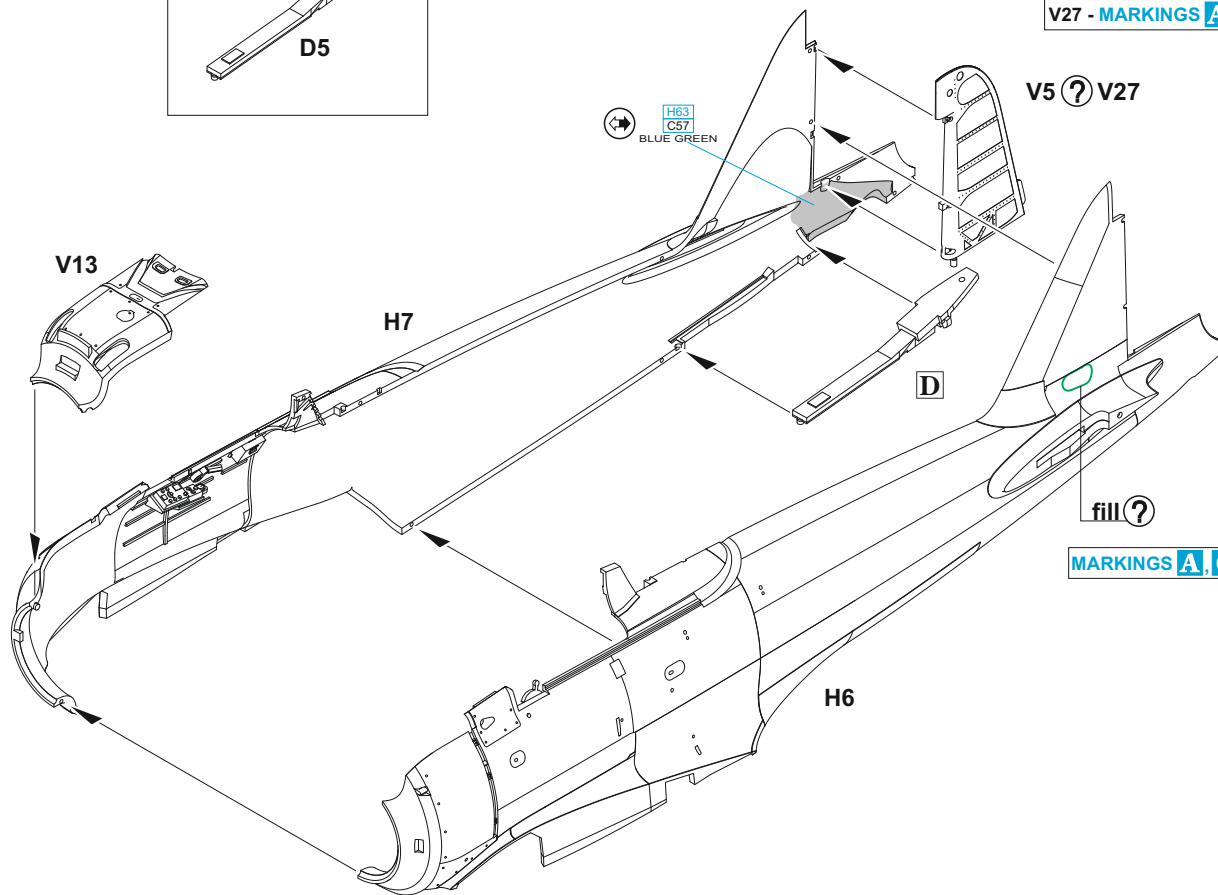

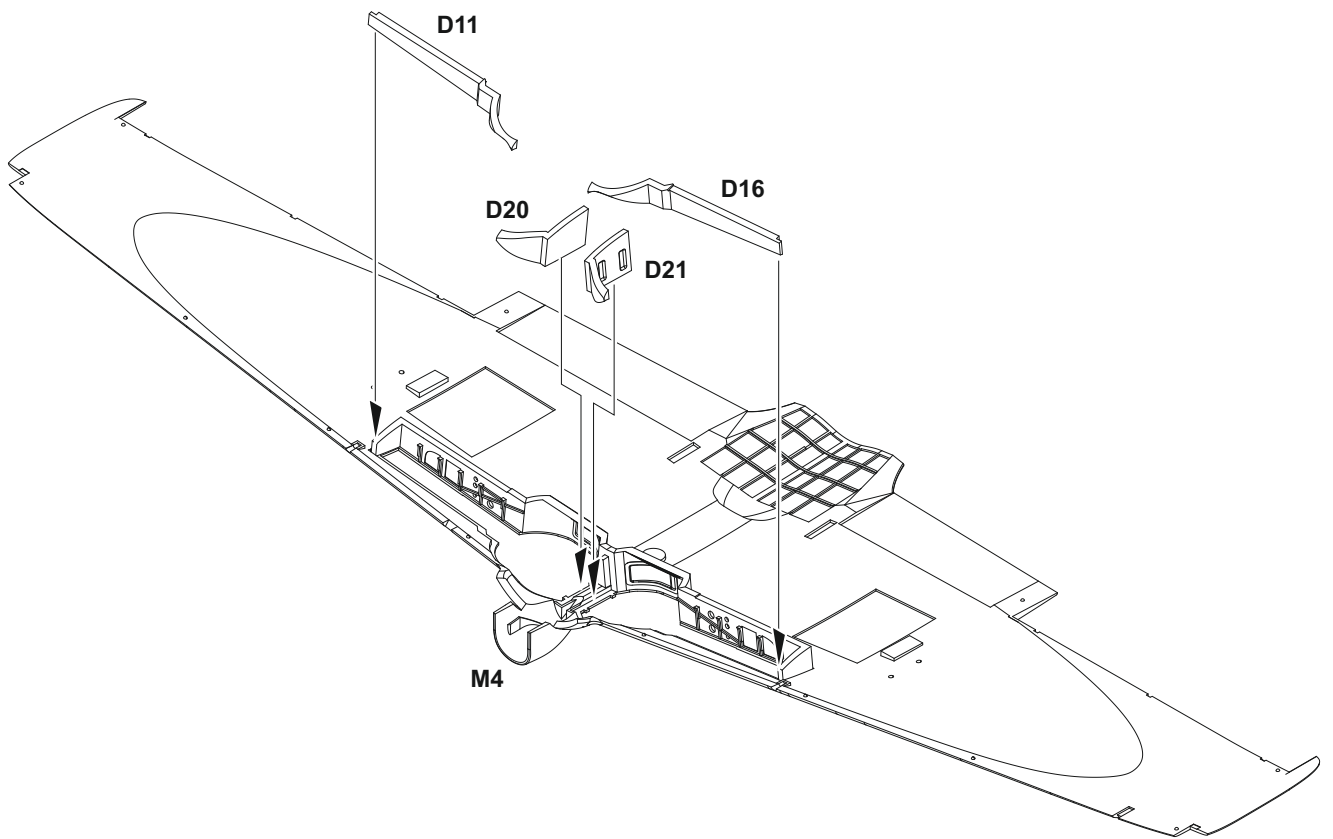
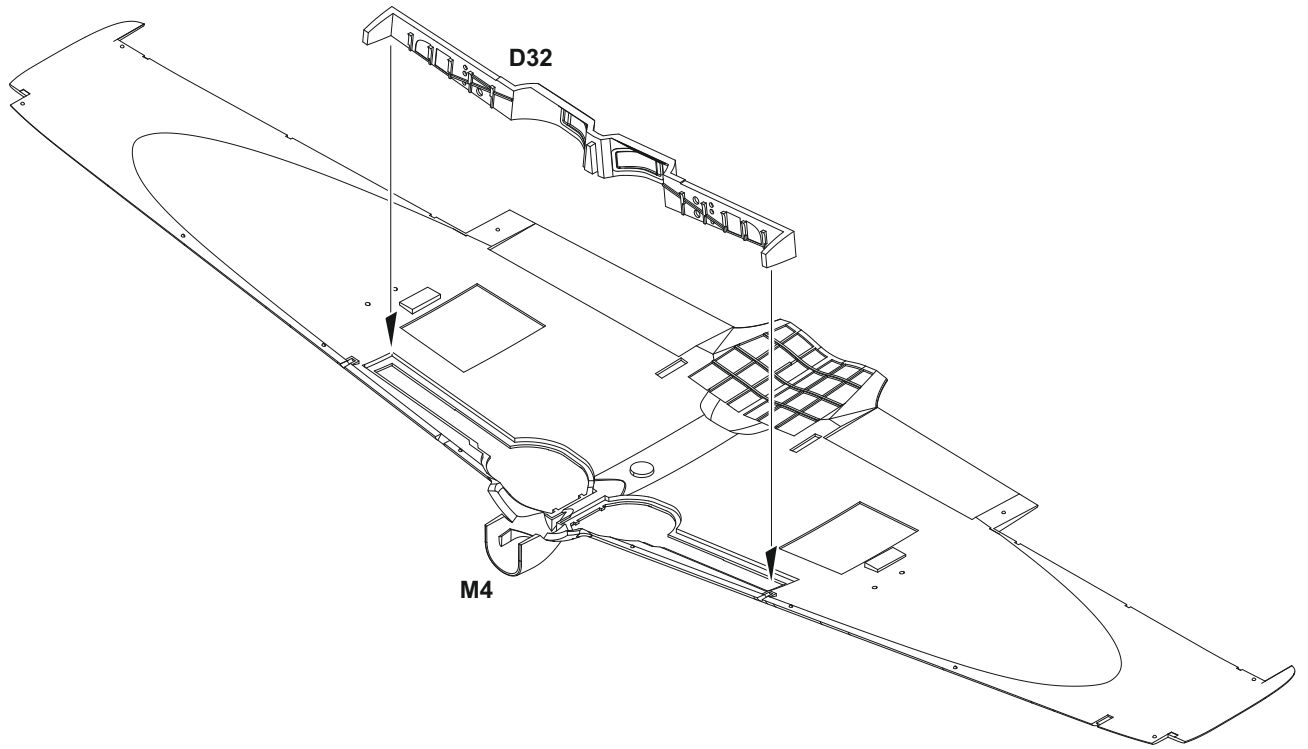

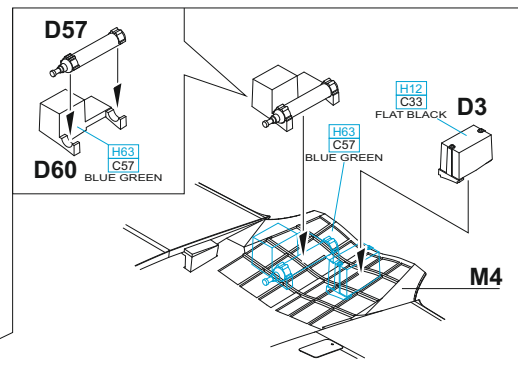
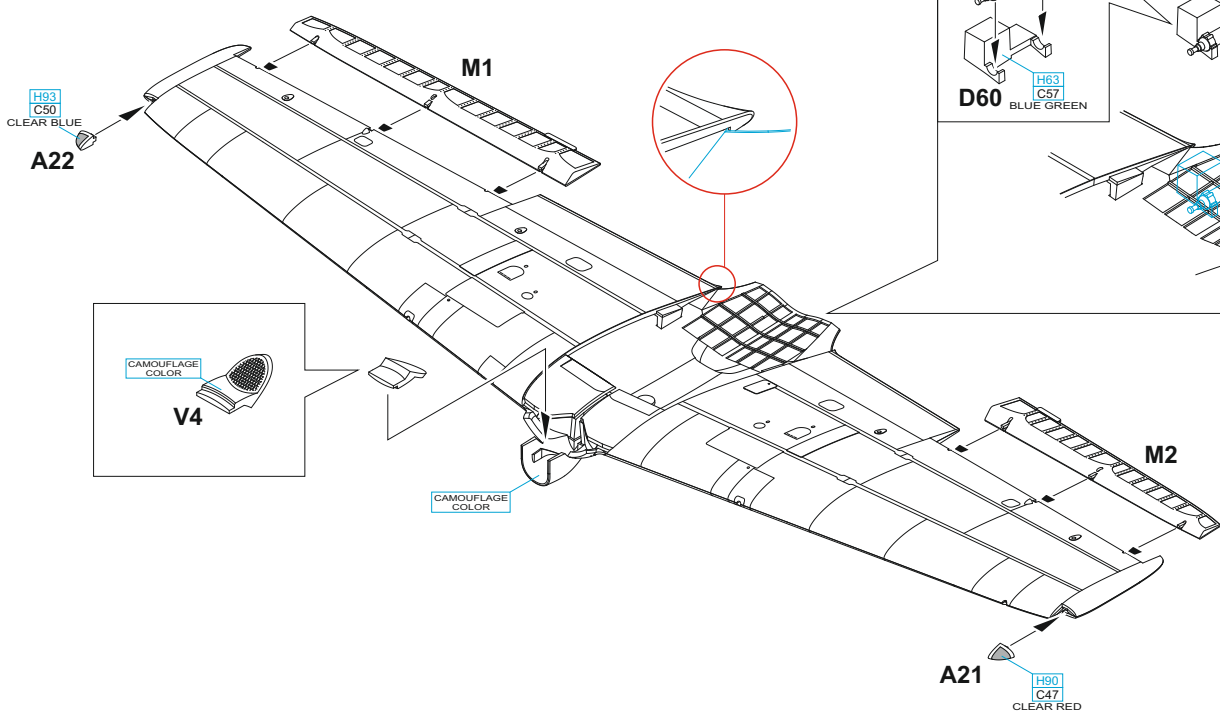
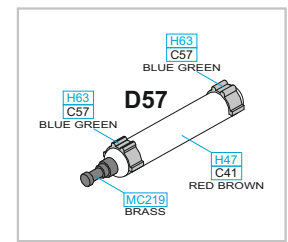
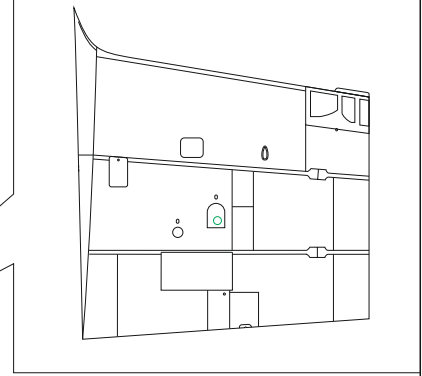
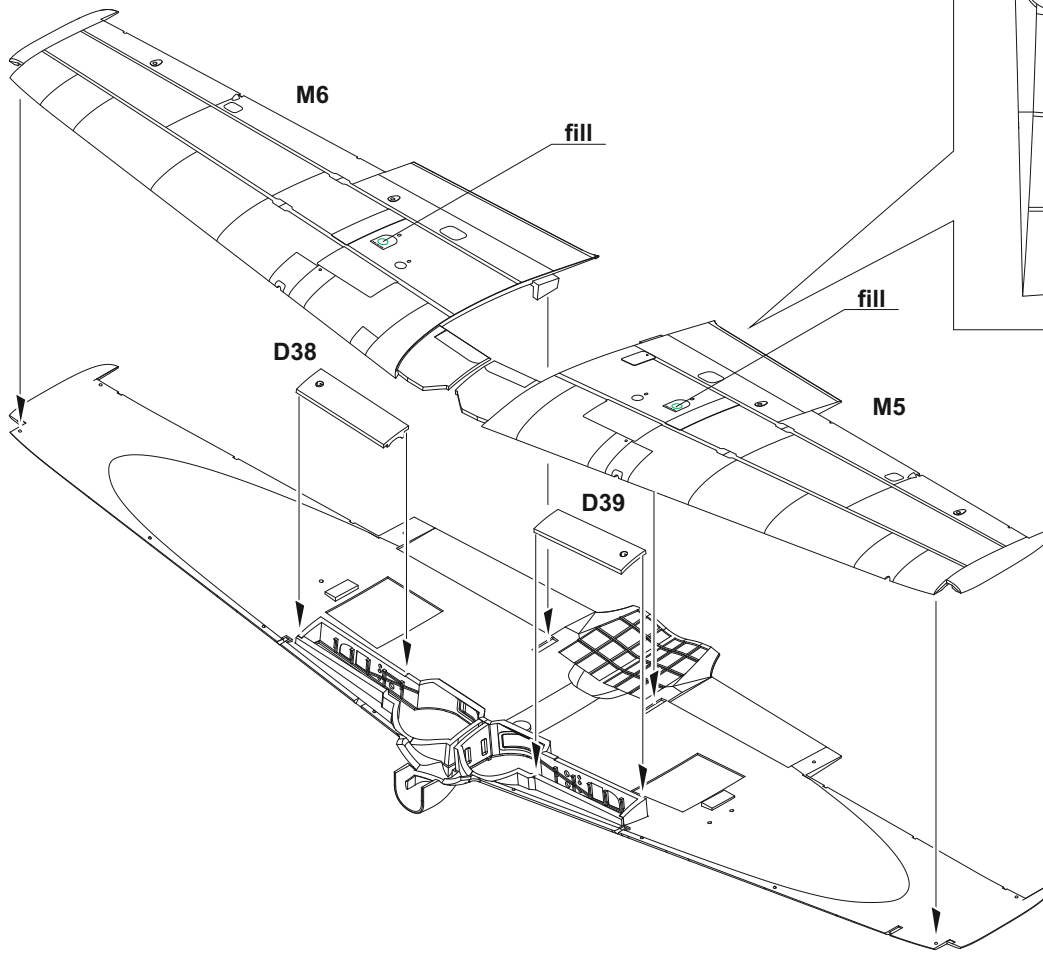

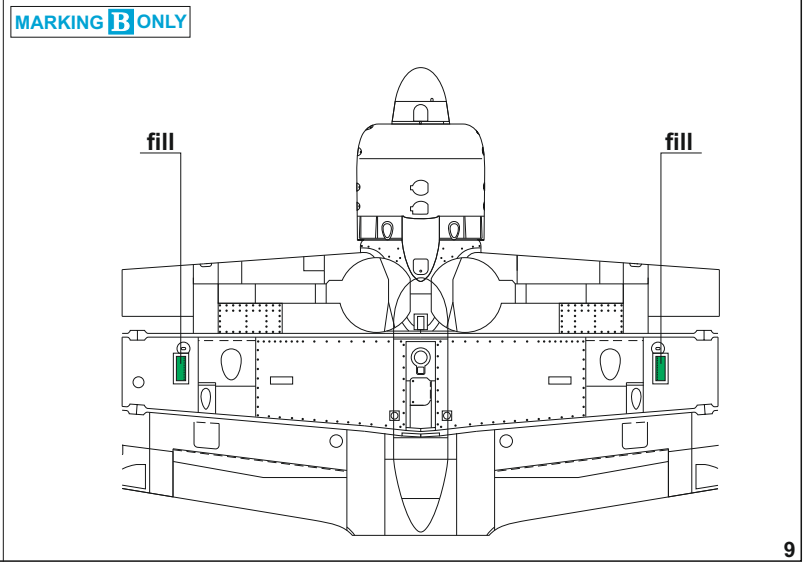
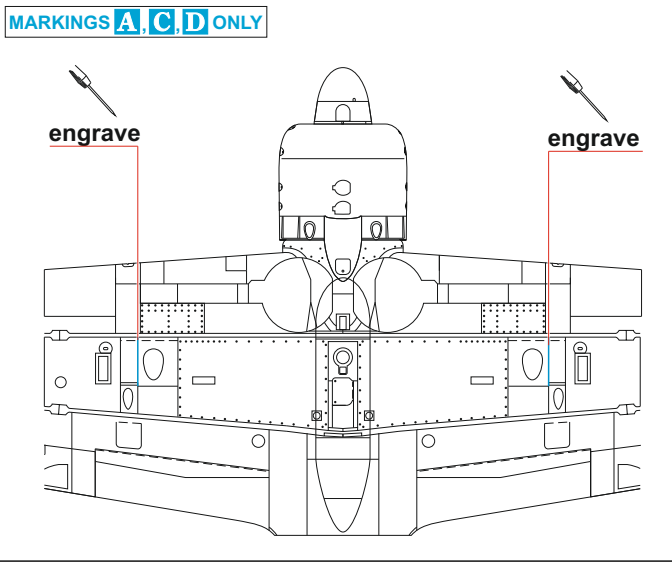
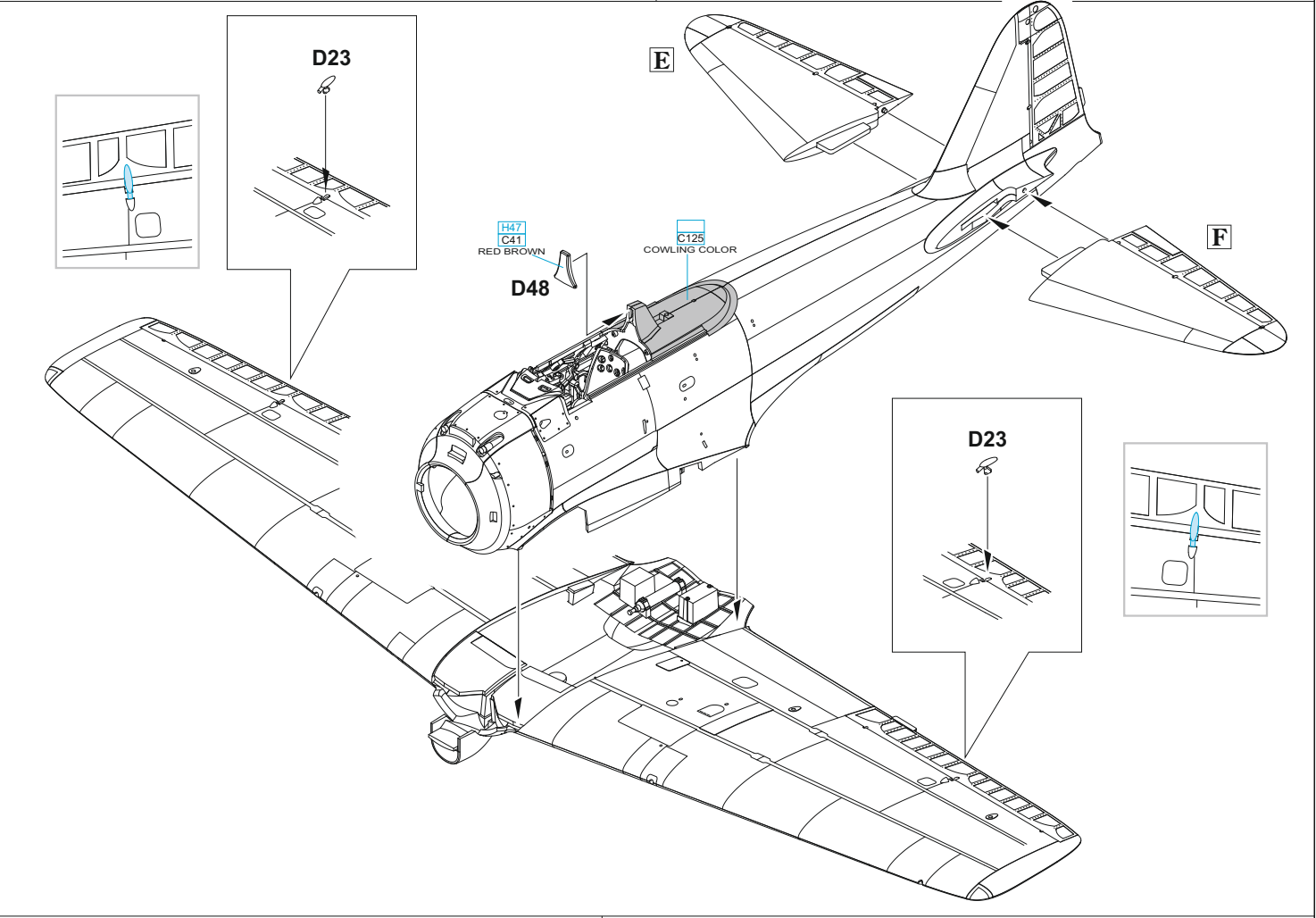
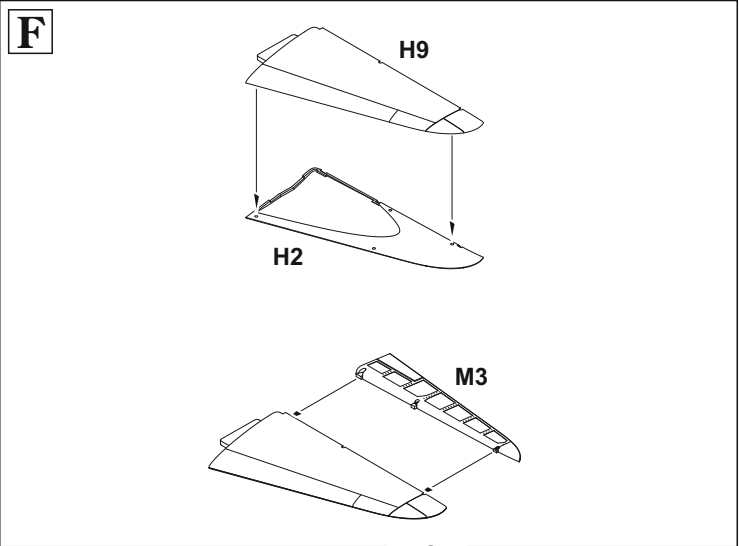
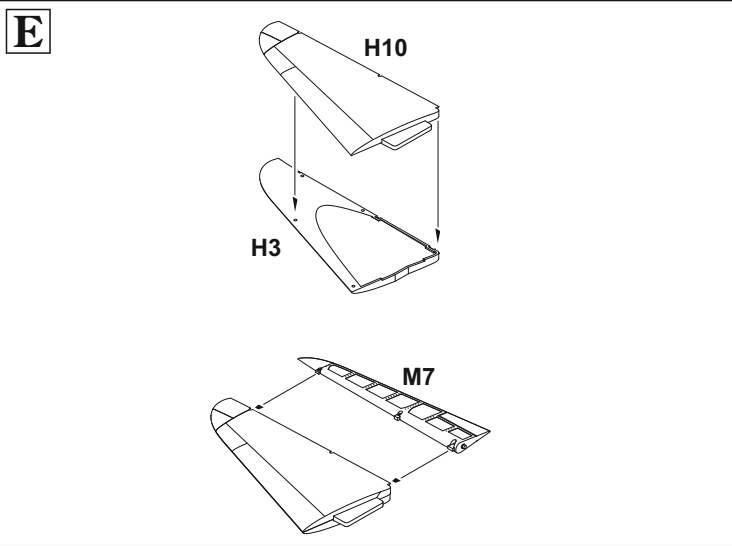

G

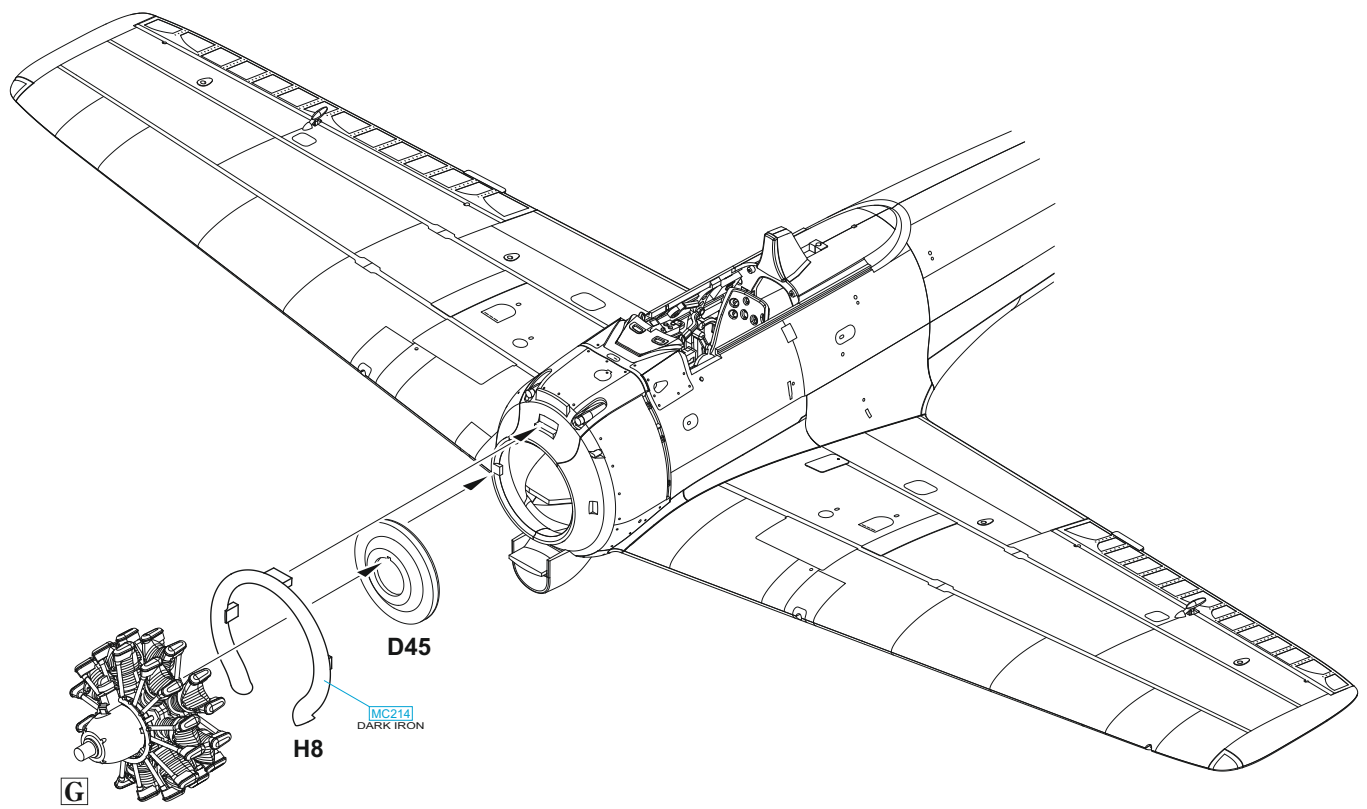
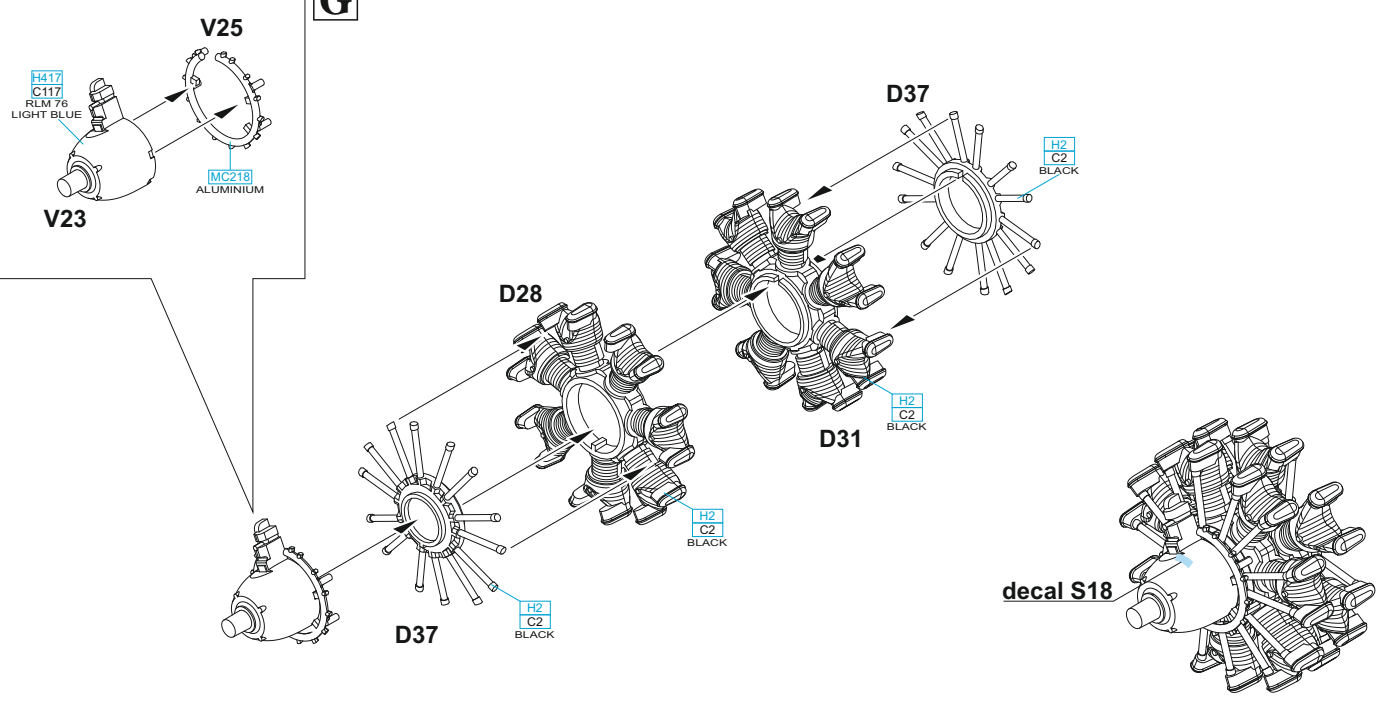

H

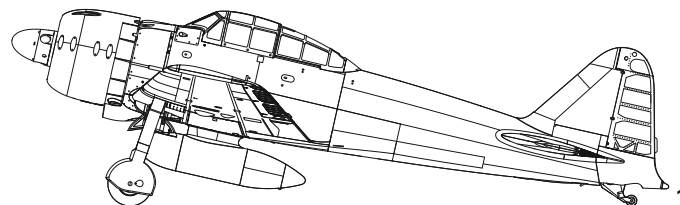
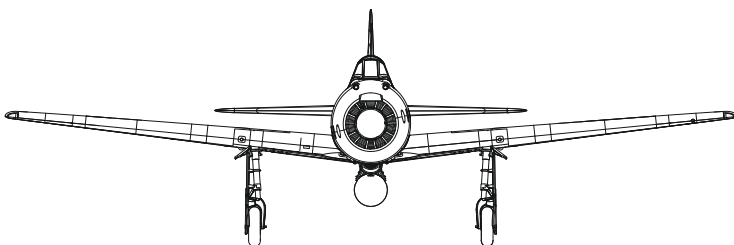
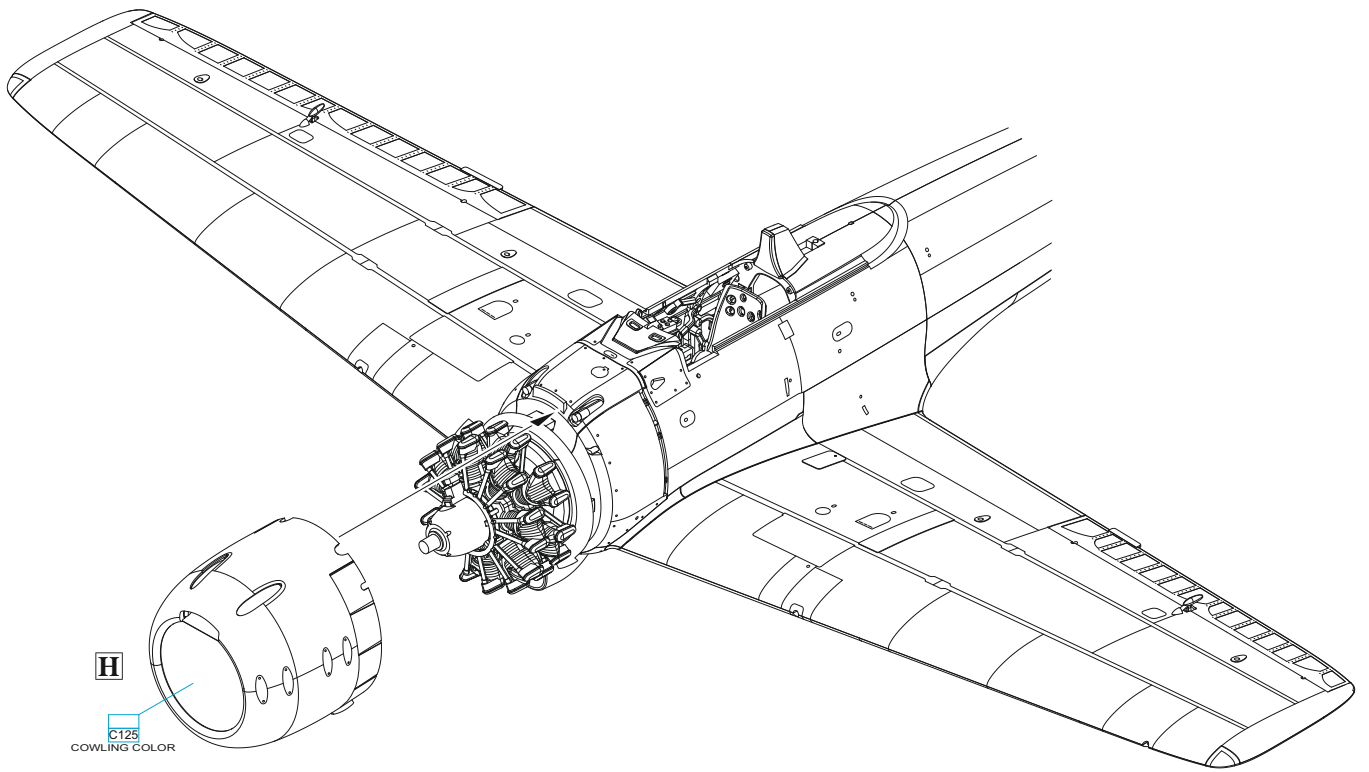
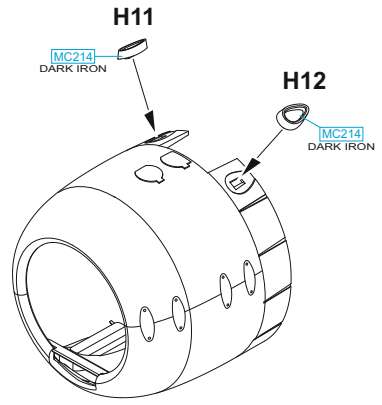
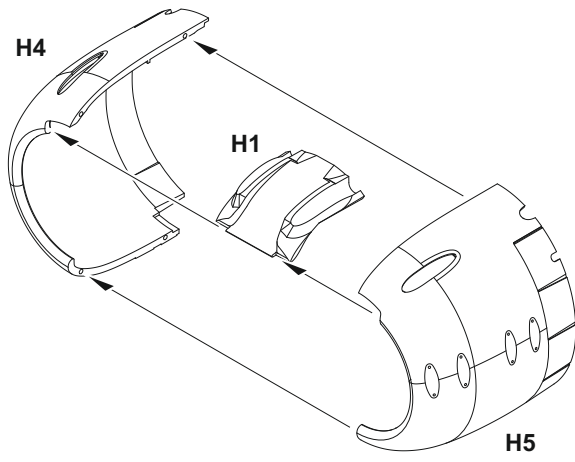

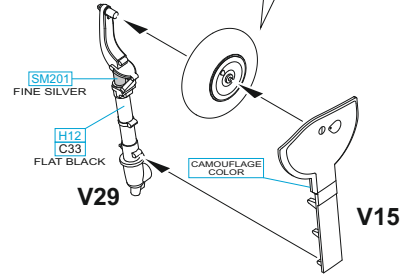
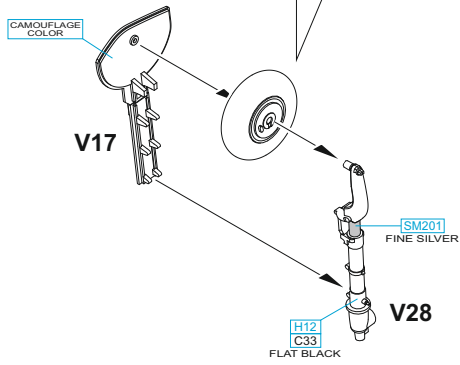
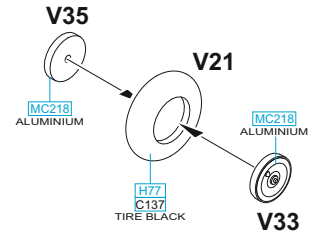
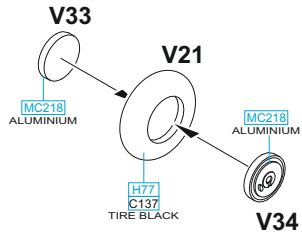

FRONT VIEW

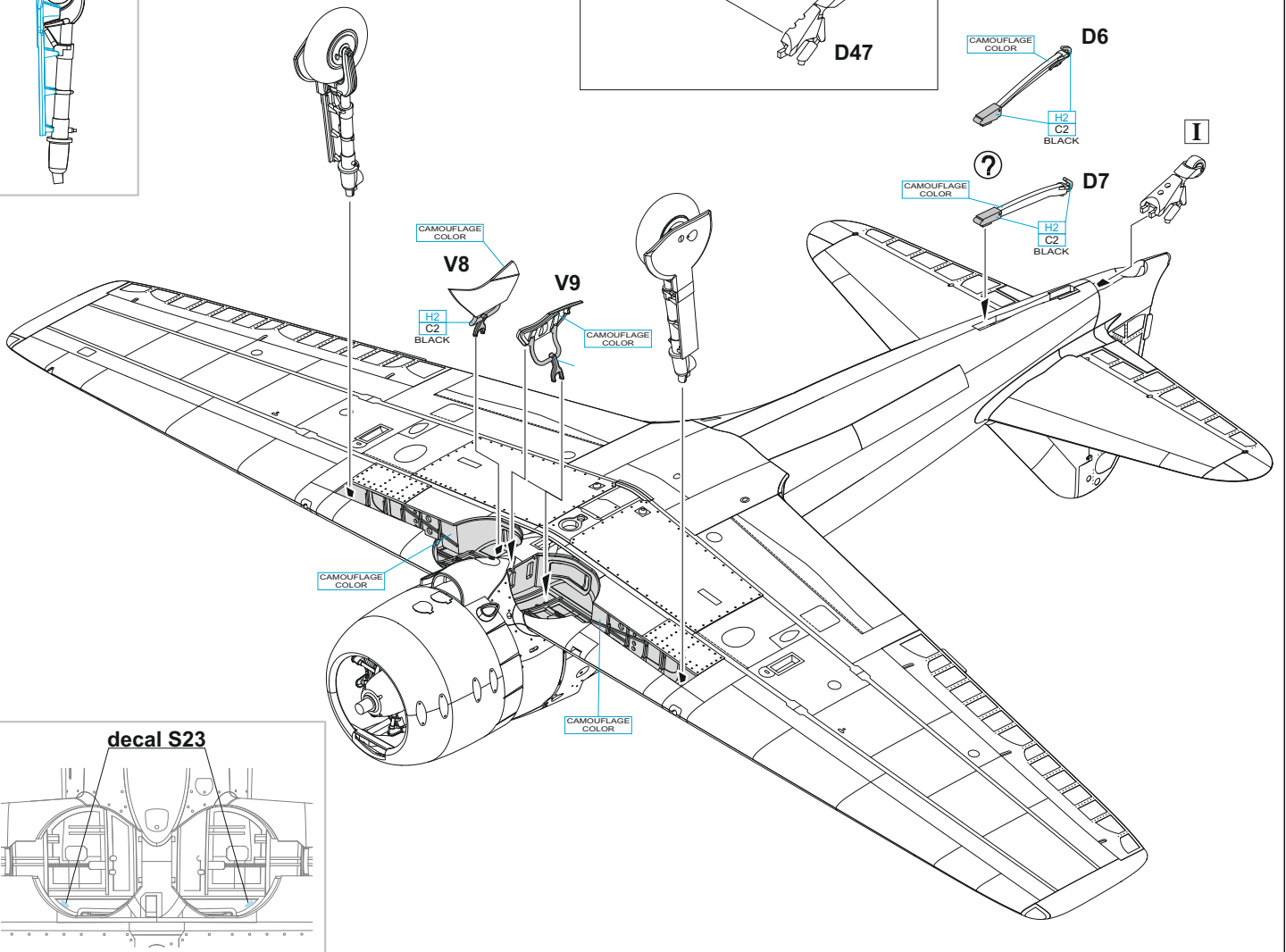
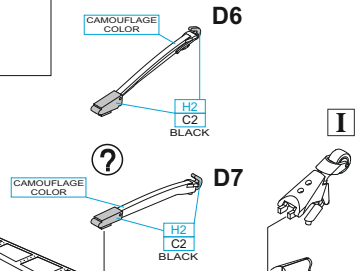
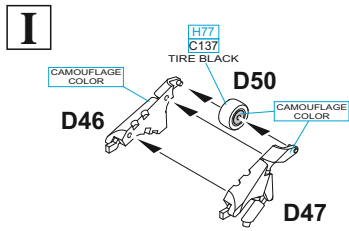
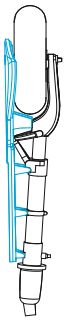

decal S23

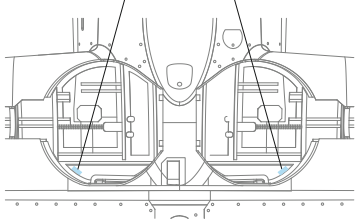

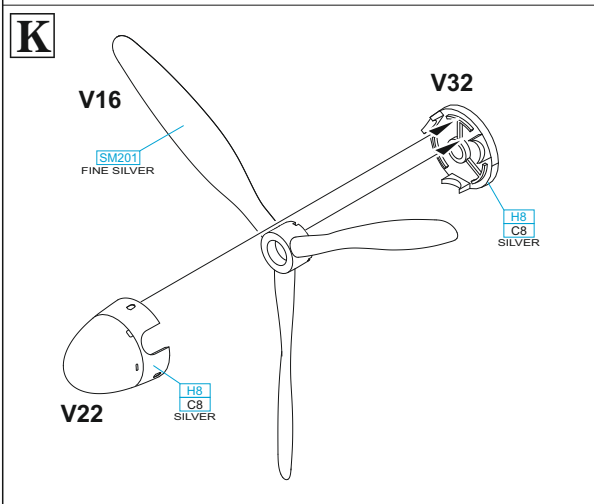
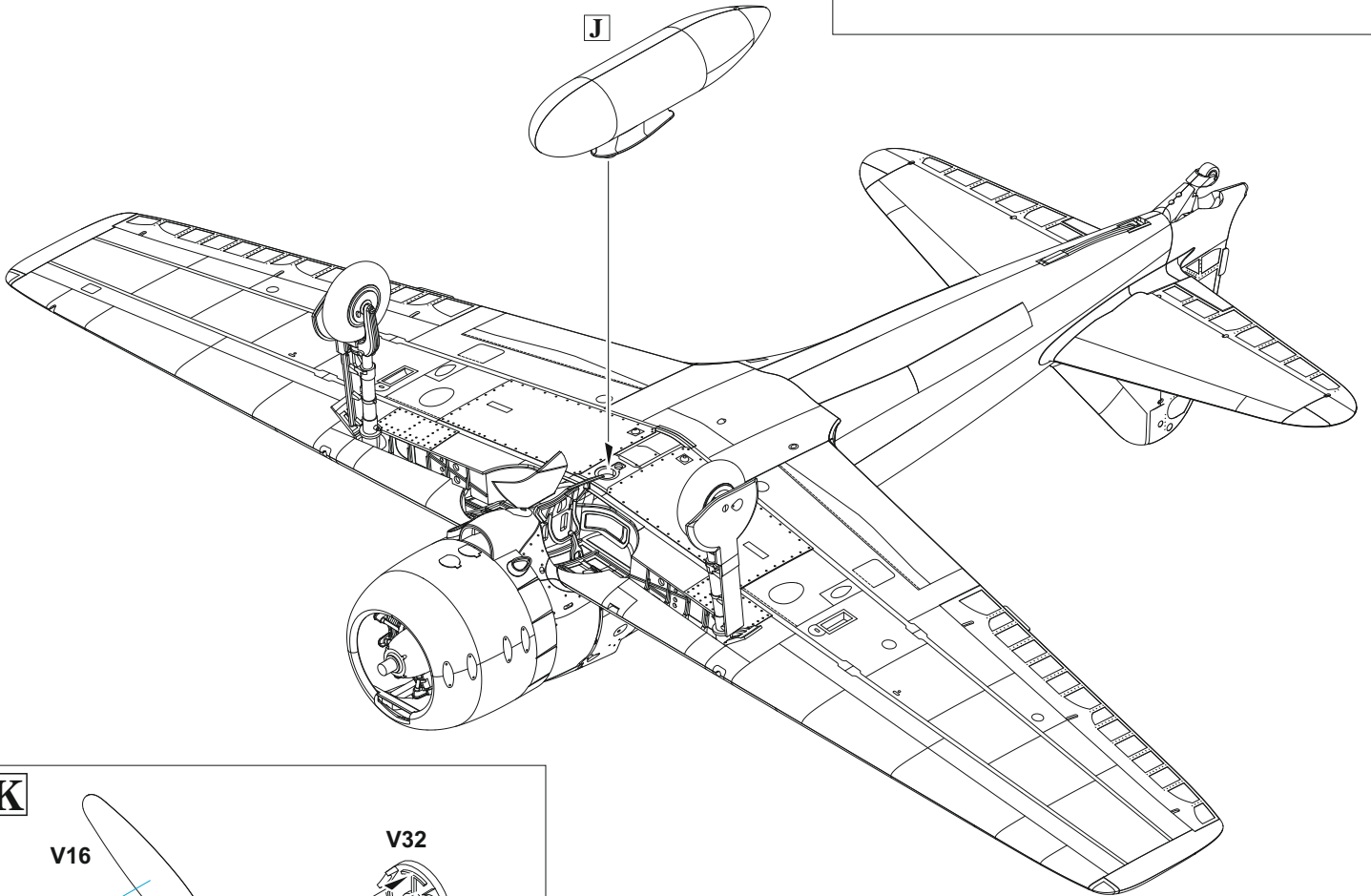
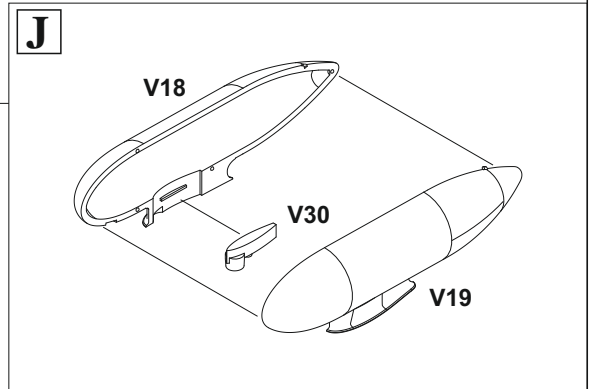
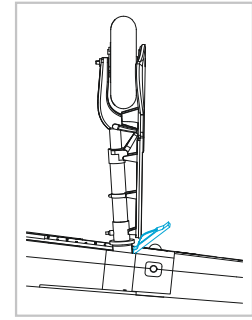
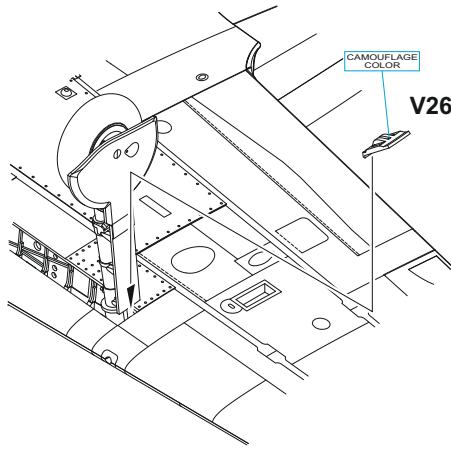

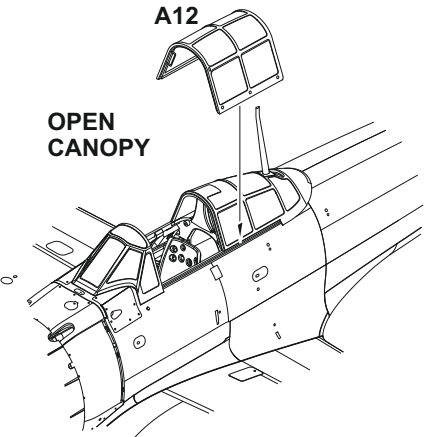
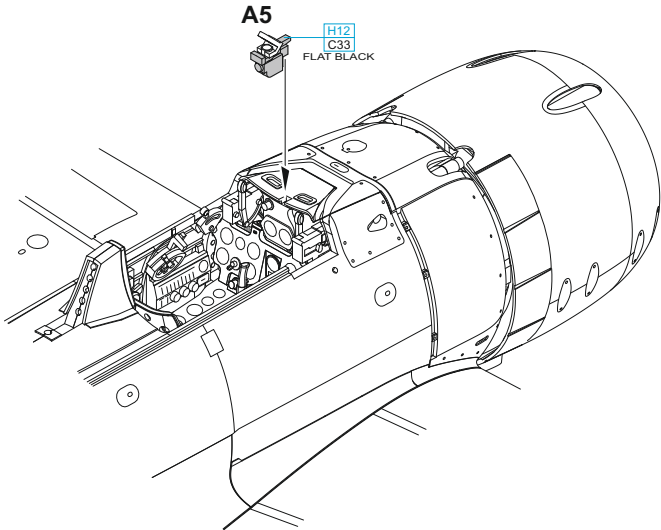
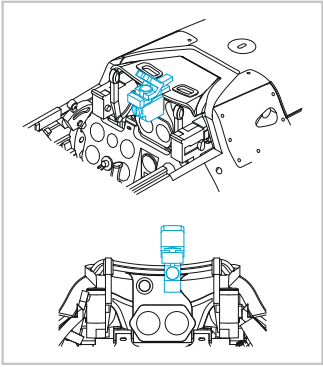

CLOSED CANOPY

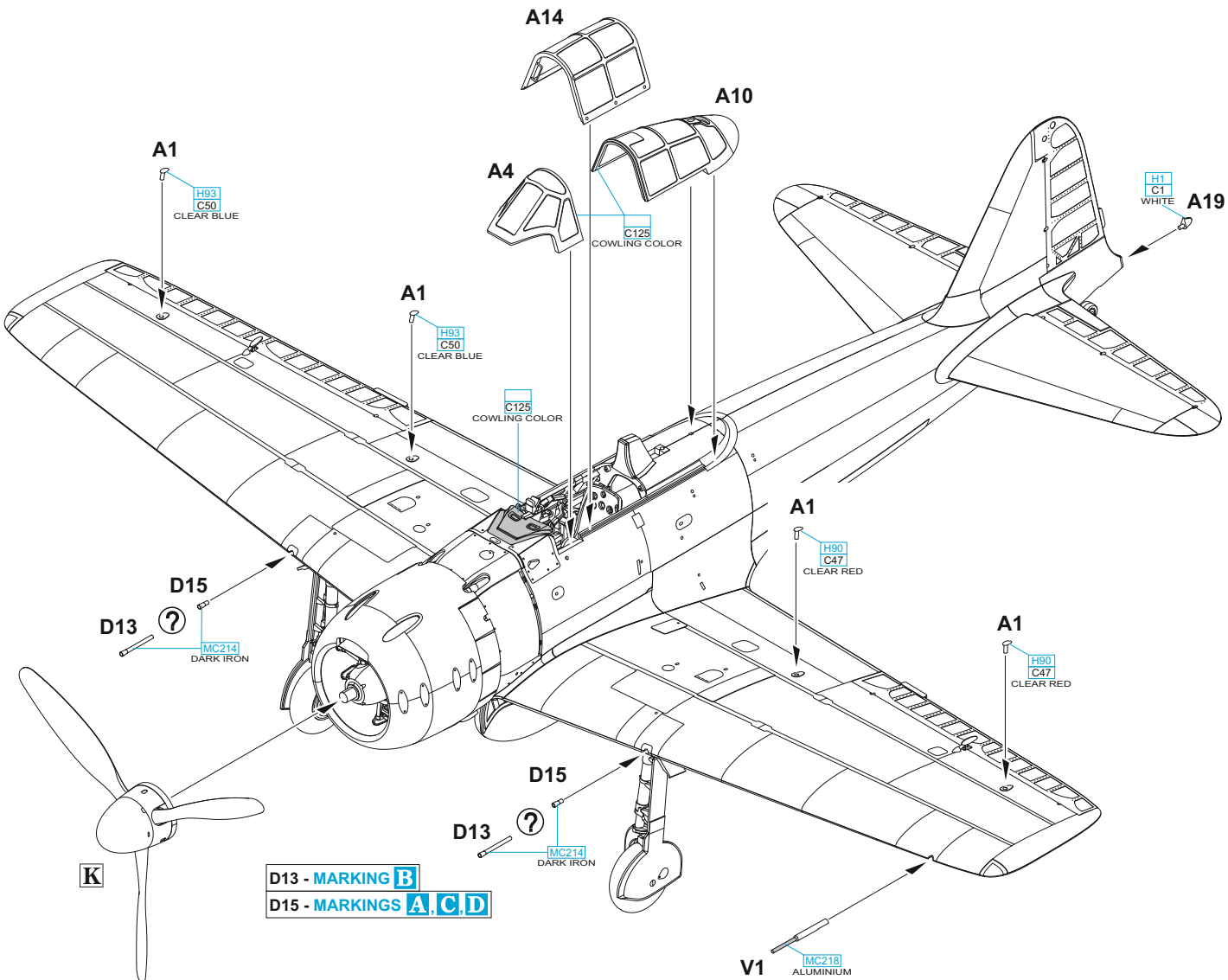

D13 - MARKING B
D15 - MARKINGS A, C, D

A c/n 3028, Tainan Kōkūtai, Buna airfield, New Guinea, August 1942

This aircraft, released by Mitsubishi on June 28, 1942, was assigned to Lt. Inano, commander of Buna detachment of Tainan Kōkūtai. It was donated by citizens of Hongwon County in North Korea, captured by Allied units at Buna on December 27, 1942 and selected for further evaluation as well as rebuild. Allied personnel at Eagle Farm Field built a flyable A6M3 Zero using parts of three Zeros transported from Buna Airfield. Inano's surname was originally Takabayashi, but he changed that before mid-1941. In late November 1941, smaller part of Tainan Kōkūtai under his command was transferred to French Indochina and temporarily became part of 22. Kōkū Sentai HQ fighter squadron. Lt. Inano returned to Tainan Kōkūtai in July 1942 to participate in combat over New Guinea and Guadalcanal. From January 1943 he was involved in evaluation of weapons for new naval aircraft. From October 1944 he served as Hikōtaichō of Tainan Kōkūtai (II) in Taiwan.

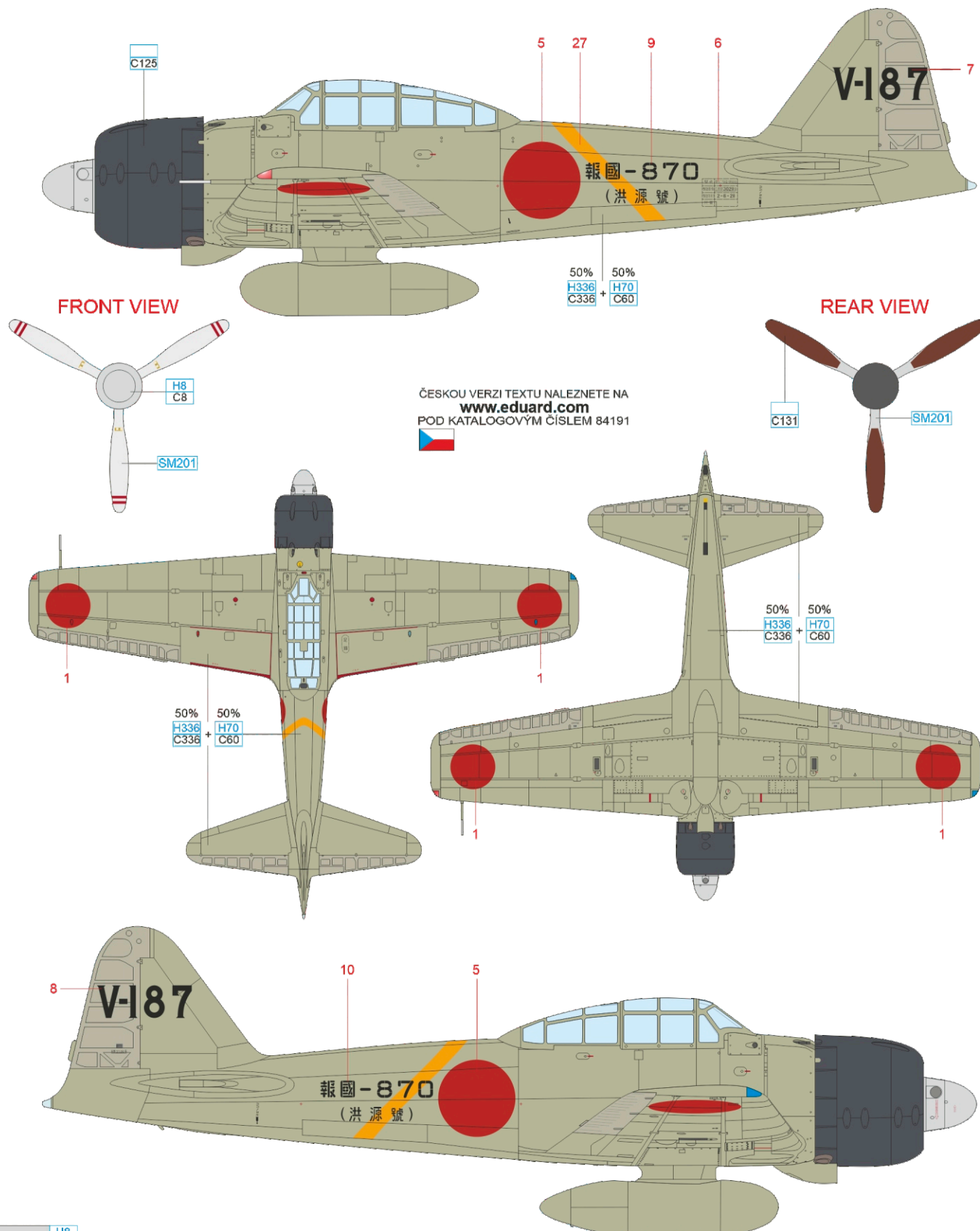

ČESKOU VERZI TEXTU NALEZNETE NA
www.eduard.com
 POD KATALOGOVÝM ČÍSLEM 84191



SILVER	H8 C8
HEMP	H336 C336
GRAY	H70 C60
COWLING COLOR	C125
RED BROWN	C131
SUPER FINE SILVER	SM201

B c/n 3305, Kōkūtai 204, Buin, Bougainville island, Solomon islands, January 1943

This aircraft was manufactured by Mitsubishi, probably on November 25, 1942. The radio equipment has been dismantled due to weight reduction. At the same time, it was equipped with long-barrel guns and a later type rudder trim that could be operated from the cockpit. Previously known aircraft of this unit with yellow fuselage markings had identification numbers of values under 148. The wreckage of this aircraft was recovered by the Allies in May 1944 off Kolombangara Island. The camouflage and markings would indicate that its pilot was leader of Chūtai of Kōkūtai 204 in early 1943. The first candidate could be Lt. Tatenoshin Tanoue, who was shot down in a dogfight with Wildcats from VMF-121 on January 15, 1943, while covering a convoy. However, the crash site is too far from the area where combat took place. The pilot of the aircraft may have been a Lt(jg) Kiyoharu Shibuya, who was lost on January 23, 1943, in dogfight with the Wildcats of VMO-251 while escorting the cargo vessel Toa Maru 2 and the destroyer Oshio.

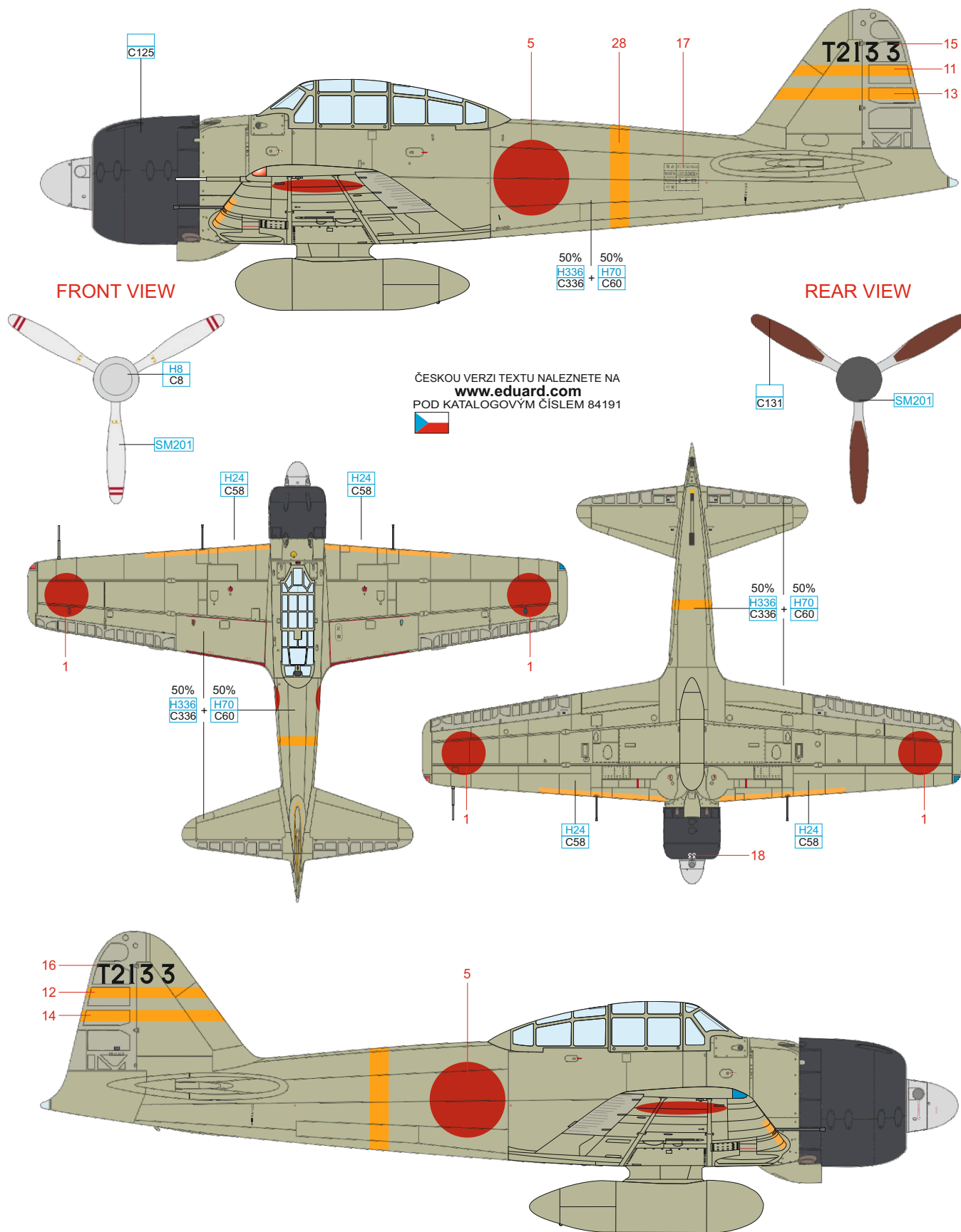

ČESKOU VERZI TEXTU NALEZNETE NA
www.eduard.com
 POD KATALOGOVÝM ČÍSLEM 84191



SILVER	H8 C8	ORANGE YELLOW	H24 C58
HEMP	H336 C336	GRAY	H70 C60
COWLING COLOR	C125	RED BROWN	C131
SUPER FINE SILVER	SM201		

C Warrant Officer Matsuo Hagiri, Rabaul, New Britain, July 1943

This aircraft was painted in green camouflage applied in field conditions and had radio equipment removed to reduce weight. Kōkūtai 204 appears to have been the only unit in the area to apply green field camouflage plus white outline of Hinomaru on fuselage and upper wing surfaces. Its pilot was Matsuo Hagiri. He was born in 1913 in Shizuoka Prefecture and served with the Yokosuka Kōkūtai from 1935. In 1937 and 1938 he served on the aircraft carrier Sōryū and took part in battles in China. In 1940, he was among the pilots of the 12th Kōkūtai who first tested the Zero in combat conditions. In the raid on Chengtu on October 4, 1940, he was one of four pilots who landed at an enemy base and set its equipment afire. More to it, Hagiri shot down three Chinese fighter aircraft after take off from the burning enemy base. After further service with Yokosuka Kōkūtai, including tests of the Raiden and Zero Model 32, he was assigned to Kōkūtai 204 in July 1943. In a dogfight on September 24 over Vella Lavella, he managed to score two victories, but suffered injuries himself and had to be transported to Japan. In April 1945, he was wounded again, this time in combat against a B-29. In all, he achieved 13 victories. After the war, he became a Fuji City Councilor and a member of the Shizuoka Prefectural Council. He died in January 1997.

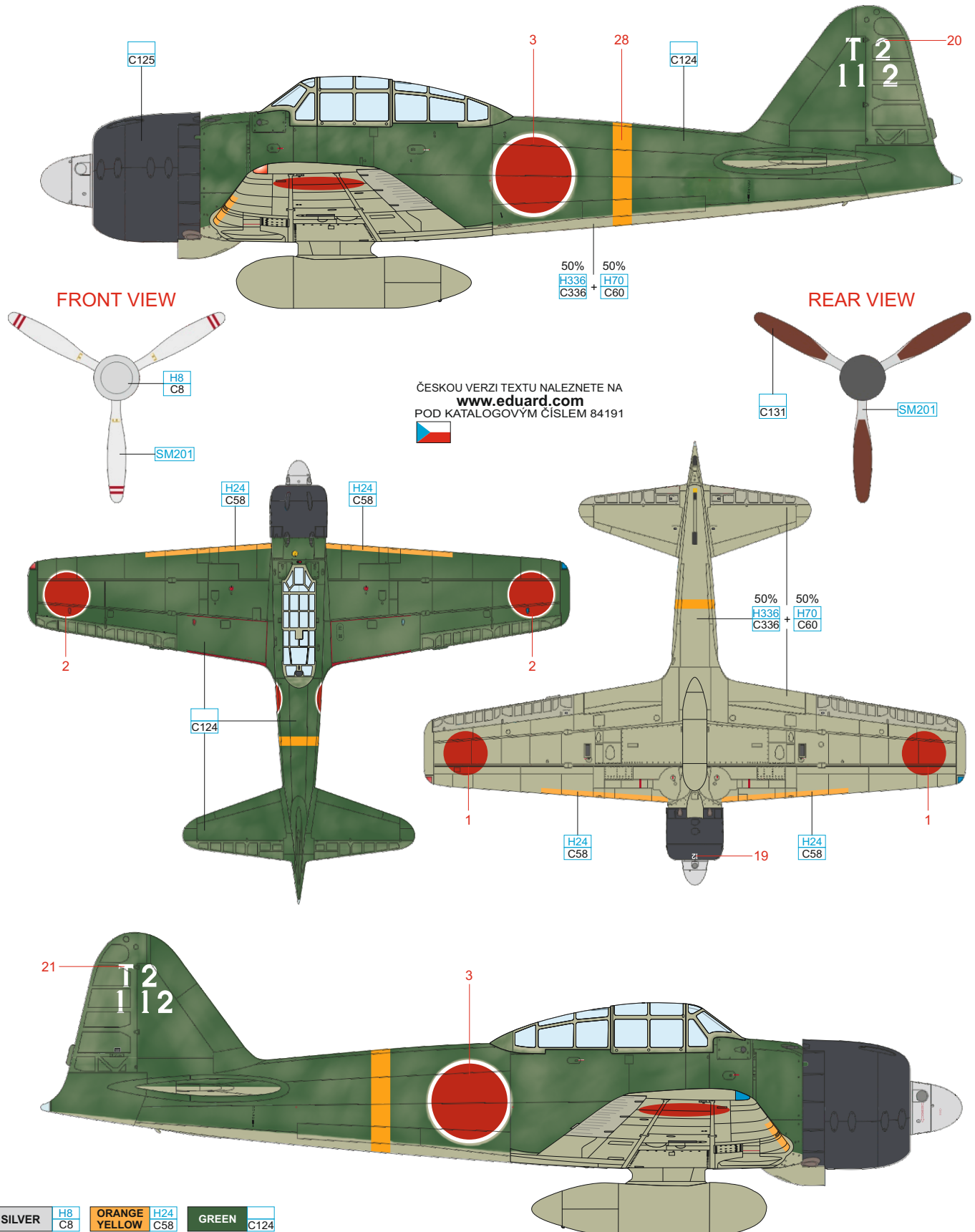

ČESKOU VERZI TEXTU NALEZNETE NA
www.eduard.com
 POD KATALOGOVÝM ČÍSLEM 84191



SILVER	H8 C8	ORANGE YELLOW	H24 C58	GREEN	C124
HEMP	H336 C336	GRAY	H70 C60	COWLING COLOR	C125
		RED BROWN	C131	SUPER FINE SILVER	SM201

D c/n 3285, Rabauru Kōkūbuntai, Rabaul, New Britain, August 1943

This aircraft was manufactured by Mitsubishi in November 1942 and early the following year received field camouflage consisting of elongated green spots on the factory paint of light grey. Its markings were changed several times. The reconstruction of both markings of this aircraft is based on parts of the wreck that have been photographically documented. The tail apparently first bore the designation T2, which would place it with Kōkūtai 204. In mid-1943, it bore the white code 3-174 and a white square was painted around Hinomaru on the side of both sides of the fuselage. This is the only Zero so far where such a marking was photographically documented. The exact purpose of the white square is unknown and it was removed in August 1943. In the second half of that year, the tail codes of the aircraft of the Rabaul fighter units changed and numerals ranging from 1 to 9 began to be used. The assignment of the numerals to individual units is still not reliably determined. Aircraft with these markings are unofficially assigned to a combat group called Rabauru Kōkūbuntai (Rabaul Air Force). There are several theories to explain the meaning of these numerical designations. The only unit that used several A6M3 Model 32s in the area in the second half of 1943 was the aforementioned Kōkūtai 204.

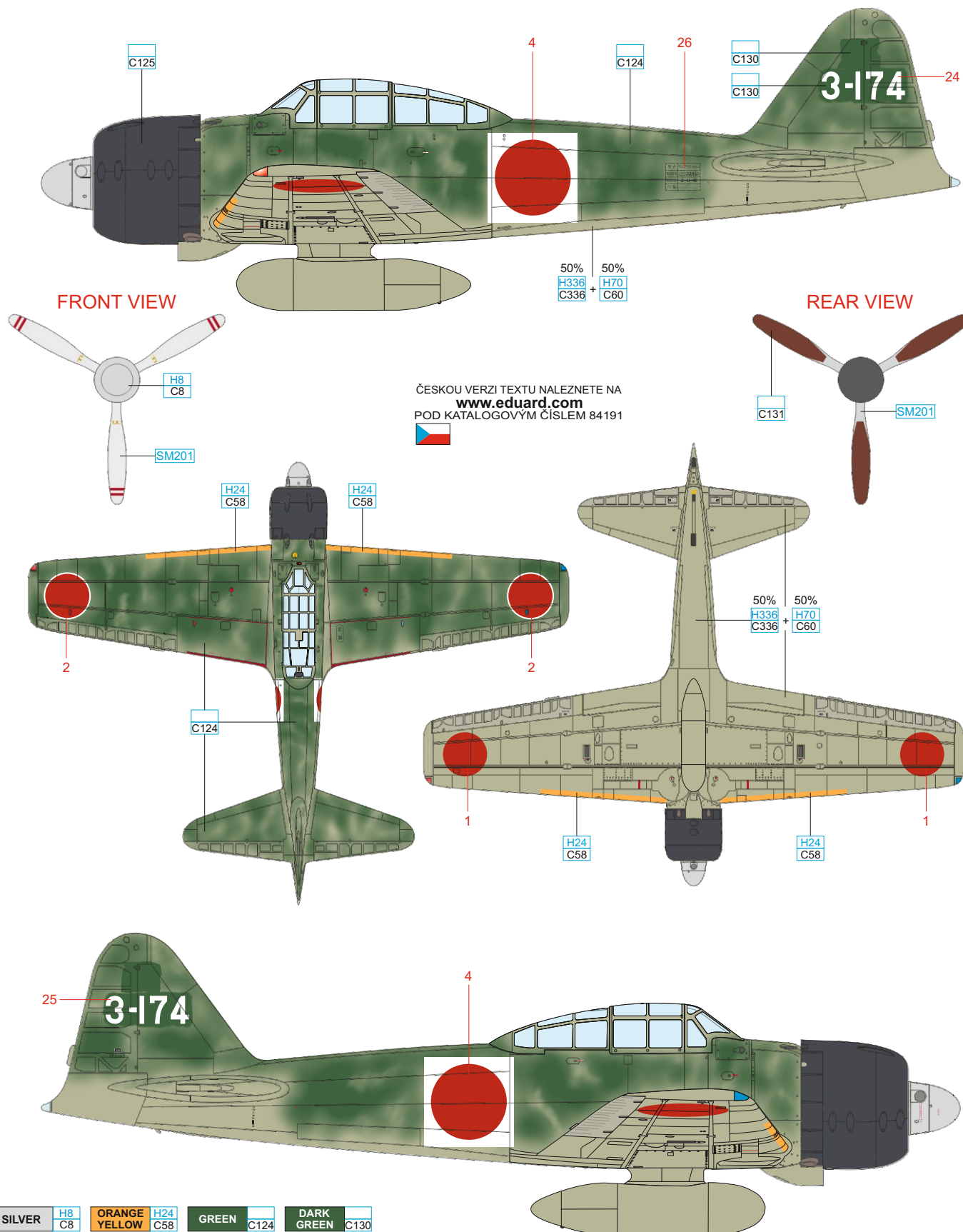

ČESKOU VERZI TEXTU NALEZNETE NA
www.eduard.com
 POD KATALOGOVÝM ČÍSLEM 84191



SILVER	H8 C8	ORANGE YELLOW	H24 C58	GREEN	C124	DARK GREEN	C130
HEMP	H336 C336	GRAY	H70 C60	COWLING COLOR	C125	RED BROWN	C131
						SUPER FINE SILVER	SM201

In August 1943, the white squares on the side of this aircraft were repainted and its marking was later changed from white 3-174 to yellow code 5-136. In September and October 1943, Kōkūtai 204 operated in this area with the last two Model 32s. It is likely, therefore, that despite the change of the tail code this Zero was still in service with this unit. Most of unit's armament consisted of A6M2 Model 21 and A6M3 Model 22, and it also received its first A6M5 Model 52 during this period. Following the neutralization of the Ballale base, the unit lost one Model 32. This was apparently aircraft with serial number 3285, which was salvaged from Ballale in 1968 by Robert Diemert. It showed the strafing damage that occurred while the aircraft was on the ground. Zero 3285 was stored at Friendship Airfield in Canada and some of its parts were used to rebuild other Zeros. It was later purchased by John and Earl Calverley of the Blyd Corporation. After that, 3285 was in a collection in Australia where John Fallis purchased it several years ago with the help of Graham Orphan of New Zealand's Classic Wings magazine and is restoring it to airworthy condition at his company CHUZY SUZY LLC in Lafayette, Louisiana. In 2022, the aircraft parts were photographed by Eduard staff and with the help of researcher Ryan Toews a reconstruction of both forms of this unique aircraft was made.

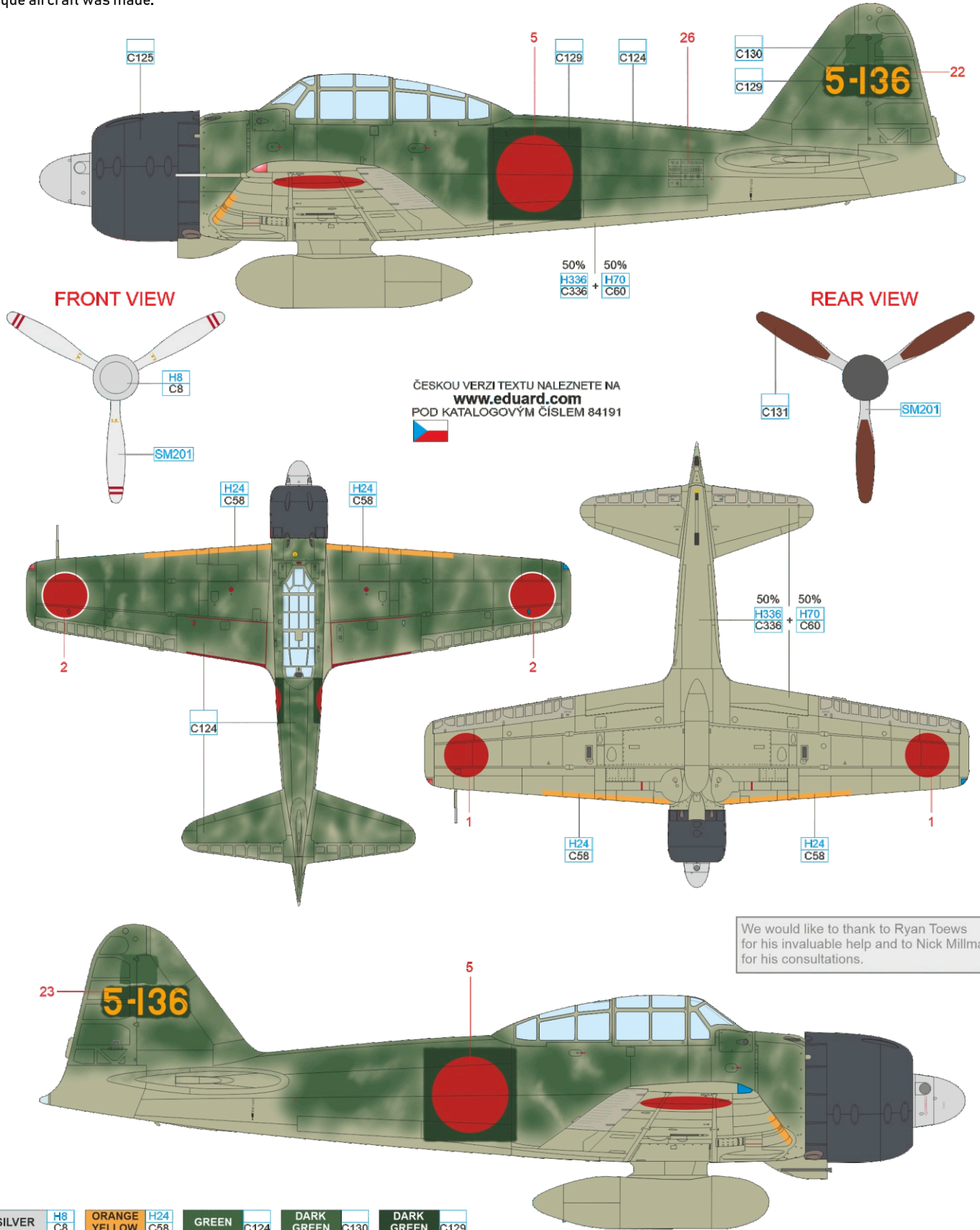

SILVER	H8 C8	ORANGE YELLOW	H24 C58	GREEN	C124	DARK GREEN	C130	DARK GREEN	C129
HEMP	H336 C336	GRAY	H70 C60	COWLING COLOR	C125	RED BROWN	C131	SUPER FINE SILVER	SM201

