

Tempest Mk.V Series 2

eduard

1/48 Scale Plastic Model Kit

WEEKEND
edition



item # 84187

The piston engine aircraft development peaked at the end of the Second World War, bringing some remarkable designs. The Hawker Tempest was one of them. This high performing beast excelled as the mid and low level fighter and attack aircraft.

The story of the Tempest is in fact nothing more than an attempt to sort out the shortcomings of Hawker Typhoon, which prevented the type from being a successful fighter. The main problem of the Typhoon was the thick wing with NACA 22 profile, offering lot of inner space for fuel and armament, but building drag rapidly with rising speed. Not surprisingly was the wing at the core of the changes on the way to the new fighter. The design was originally supposed to retain the Typhoon name marked as the Mark II but as it became obvious, the final result would be a new plane, so the name was changed. The Tempest name followed the path of Hawker to use the "wind" names for its fighters.

Series of changes

The new wing was 5 in (12,7 cm) thinner at the root and the planform changed in comparison with Typhoon wing to more elliptical shape. As the new wing did not offer enough space for fuel, additional fuel tank of 76 gallon (288 l) volume had to be installed in the fuselage. The space for it was found between the firewall and the oil tank, but, consequently, it was necessary to move the engine forward by 21 in (53,4 cm). Due to that, the tail surfaces, both the stabilizer as well as elevator, had to be enlarged, also the undercarriage was rebuilt. All in all, the Tempest really was a new aircraft, although keeping the Typhoon engine, which was a very complex issue by itself. With quite ambitious goals regarding the performance of Tempest, new units were considered instead of troubled Napier Sabre II, but the things went different way ...

Back to the roots

Early contract was placed for two prototypes based on the Typhoon airframes powered by Sabre IV engine, but, due to delays with supply, only the HM599 was fitted with it, while HM595 used old Sabre II. The two prototypes also differed in radiator layout as the HM595 retained the distinctive chin radiator of Typhoon, while HM599 undergo radical change as Sydney Camm, Hawker chief designer, attempted to streamline the design. The radiator moved to the leading edge of the inner wing sections on both sides and the sleek nose got some resemblance to the Spitfire. The wing-mounted radiators layout worked well aerodynamically, but the Sabre IV evinced multiple problems, while the complexity of the wing assembly with integrated radiators was of some concern.

There were only two other units powerful enough for use with the Tempest instead of Sabre IV: The R&R Griffon and radial Bristol Centaurus IV. As the new name Tempest was chosen, different marks were assigned to each engine variant and four more prototypes were ordered. The Mk.I was to be powered by the Sabre IV (HM599), the Mk.II by the Centaurus IV (LA602 and LA607), the Mk.III by the R&R Griffon IIB (LA610) and the Mk.IV by the Griffon 61 (LA614). Finally, the Mk.V (HM595) used slightly improved version of the Sabre II (IIB) engine producing 2,400 hp (1,790 kW), thus 200 hp (147 kW) more than previous one. Although it was meant as a stopgap solution until Sabre

IV engines would be available, it finally emerged as the main mark of the Tempest, because Centaurus engine supply was too late, Sabre IV was still troubled by glitches and integration of the Griffon into the Typhoon airframe proved to be more demanding than expected, so Mk.III ended with first and only prototype, while Mk.IV was never built.

Legend is born

The HM595 prototype with Sabre II flew for the first time on September 2, 1942, fitted with car door canopy, as the bubble canopy was in development at the time. Streamlined HM599 with Sabre IV performed its maiden flight on February 24, 1943. It was quite faster than HM595, but the solution of its problems would take too much time. The easiest way to get the Tempest into the service was to proceed with the Mk.V. The first production Tempest Mk.V made its maiden flight on June 21, 1943, already fitted with bubble canopy. Armed with four 20mm Hispano Mk.II cannon (200 rounds per barrel) it achieved a top speed of 432 mph (695 km/h) at 18,400 feet (5,600 m), 45 mph (72 km/h) more than Bf 109 od Fw 190 (depending on mark). After the first production batch, the Hispano Mk. V cannons were installed, differentiating the Tempest from the first batch by barrels fully covered by the wing.

The first squadron to receive Tempests was No. 486 in January 1944. Together with No. 3 Squadron it became operational in April 1944. With addition of No. 56 Squadron the first Tempest Wing was formed at Newchurch, Kent, under the command of W/C Roland Prosper „Bee“ Beamont.

Fighting everything

After the period of operations over the France following the D-Day, the Tempest Wing was tasked to fight the V-1 Flying Bombs travelling low at speed of some 400 mph (640 km/h). The Tempest Mk.V was never effective high-level fighter due to the nature of its engine, but at the middle and low levels it was superior to virtually everything. And some 640 destroyed V-1s during the short period between June and August 1944 speak by themselves, as the rest of RAF scored some 160 of them during the period.

After the V-1 bombing campaign ceased, the Tempest Squadrons returned to the common tasks. At the time, seven Tempest squadrons flew air-to-air combats, claiming 240 kills (20 of them being Me 262 jets). Most successful Tempest ace, D. C. Fairbanks (US) recorded 11 kills flying Mk. V „Terror of Rheine“. Second with nine kills came W. E. Schrader (NZ) with nine and J. J. Payton with six kills emerged as third overall. The most famous Tempest Pilot, the Free French Pierre Clostermann, added four kills to his tally of 11 (some sources state 18 kills, the precise number is unknown) flying the Tempest.

The Tempest was formidable fighter, fast, tough and with powerful weapons. Thanks to the excellent low altitude performance, the strafing attacks were quite common, usually during the „search and destroy“ rides. Apart of cannons, the provision of two 1,000lb (450kg) bombs or eight 60lb (27kg) rockets added to its destructive capabilities.

ATTENTION



UPOZORNĚNÍ



ACHTUNG



ATTENTION



注意



Carefully read instruction sheet before assembling. When you use glue or paint, do not use near open flame and use in well ventilated room. Keep out of reach of small children. Children must not be allowed to suck any part, or pull vinyl bag over the head.



Před započítím stavby si pečlivě prostudujte stavební návod. Při používání barev a lepidel pracujte v dobře větrané místnosti. Lepidla ani barvy nepoužívejte v blízkosti otevřeného ohně. Model není určen malým dětem, mohlo by dojít k požití drobných dílů.

INSTRUCTION SIGNS * INSTR. SYMBOLS * INSTRUKTION SINNBILDEN * SYMBOLES * 記号の説明

OPTIONAL
VOLBABEND
OHNOUTOPEN HOLE
VYVRTAT OTVORSYMMETRICAL ASSEMBLY
SYMETRICKÁ MONTÁŽREMOVE
ODŘÍZNOUTREVERSE SIDE
OTOČITAPPLY EDUARD MASK
AND PAINT
POUŽÍT EDUARD MASK
NABARVITPLEASE, CHECK THE LATEST VERSION OF THE INSTRUCTION ON www.eduard.com

PARTS



DÍLY



TEILE



PIÈCES



部品

B> 82120 B PLASTIC PARTS

C>

82120 C

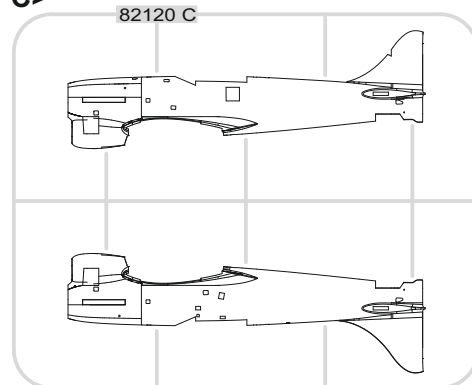
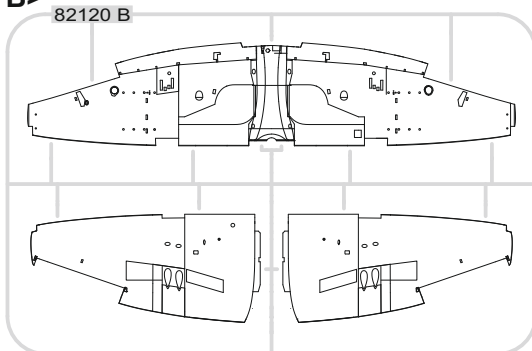
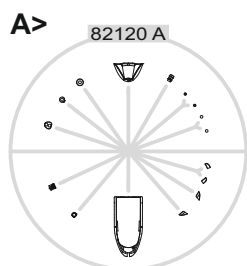

D>

82120 D

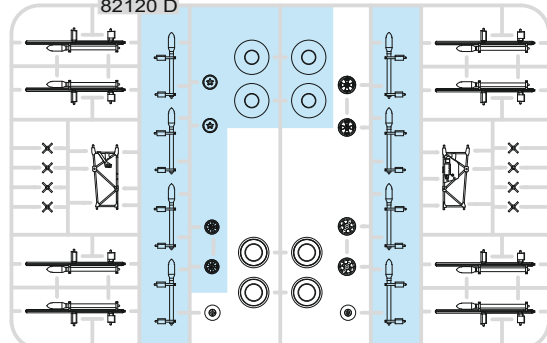

E>

82120 E

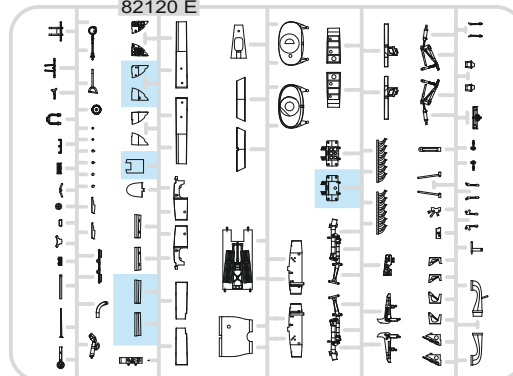

F>

82120 F

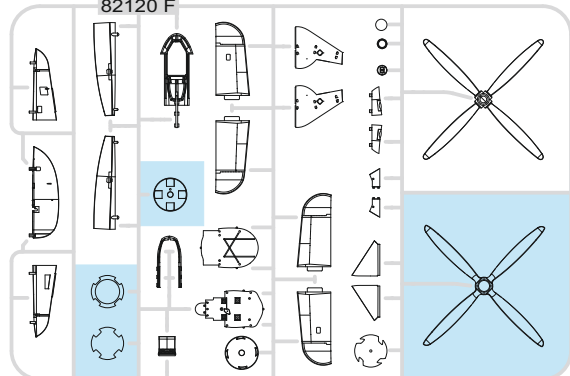

G>

82120 G

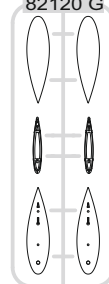

-Parts not for use. -Teile werden nicht verwendet. -Pièces à ne pas utiliser. -Tyto díly nepoužívejte při stavbě. - 使用しない部品

COLOURS



BARVY



FARBEN



PEINTURE



色

GSI Creos (GUNZE)		
AQUEOUS	Mr.COLOR	
H4	C4	YELLOW
H6	C6	GREEN
H8	C8	SILVER
H11	C62	FLAT WHITE
H12	C33	FLAT BLACK
H52	C12	OLIVE DRAB
H74	C368	SKY
H77	C137	TIRE BLACK
H90	C47	CLEAR RED
H94	C138	CLEAR GREEN

GSI Creos (GUNZE)		
AQUEOUS	Mr.COLOR	
H330	C361	DARK GREEN
H335	C363	MEDIUM SEAGRAY
	C362	OCEAN GRAY
	C364	AIRCRAFT GRAY-GREEN
Mr.METAL COLOR		
	MC214	DARK IRON
	MC218	ALUMINIUM
Mr.COLOR SUPER METALLIC		
	SM201	SUPER FINE SILVER

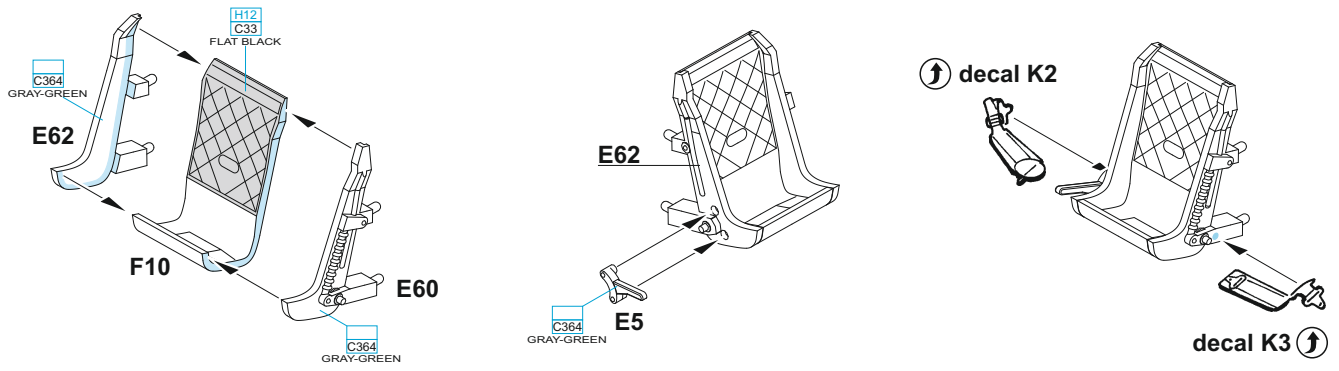
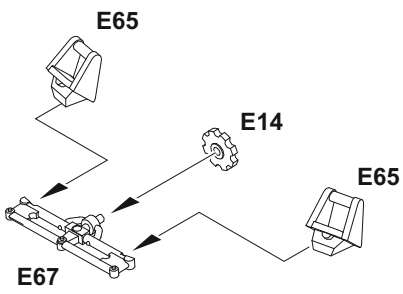
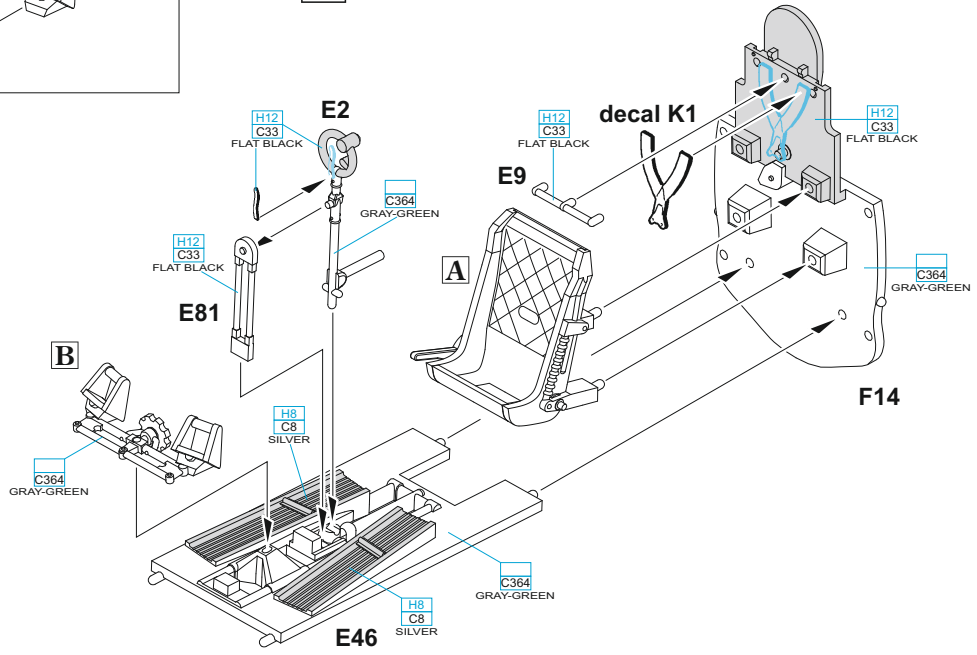
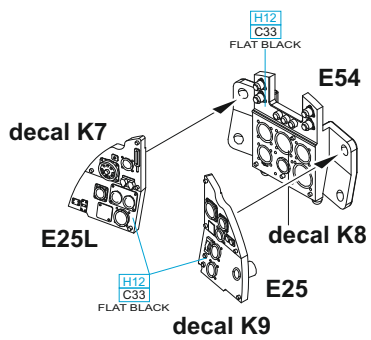
A**B****C****D**

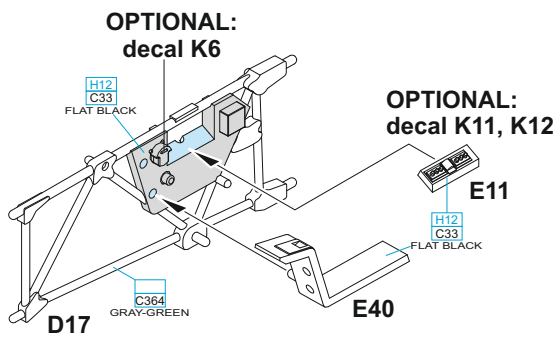
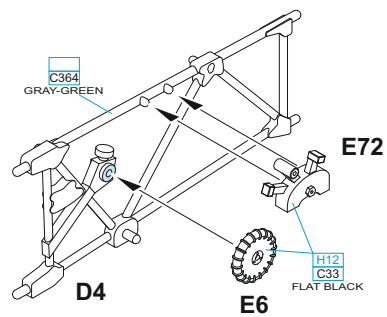
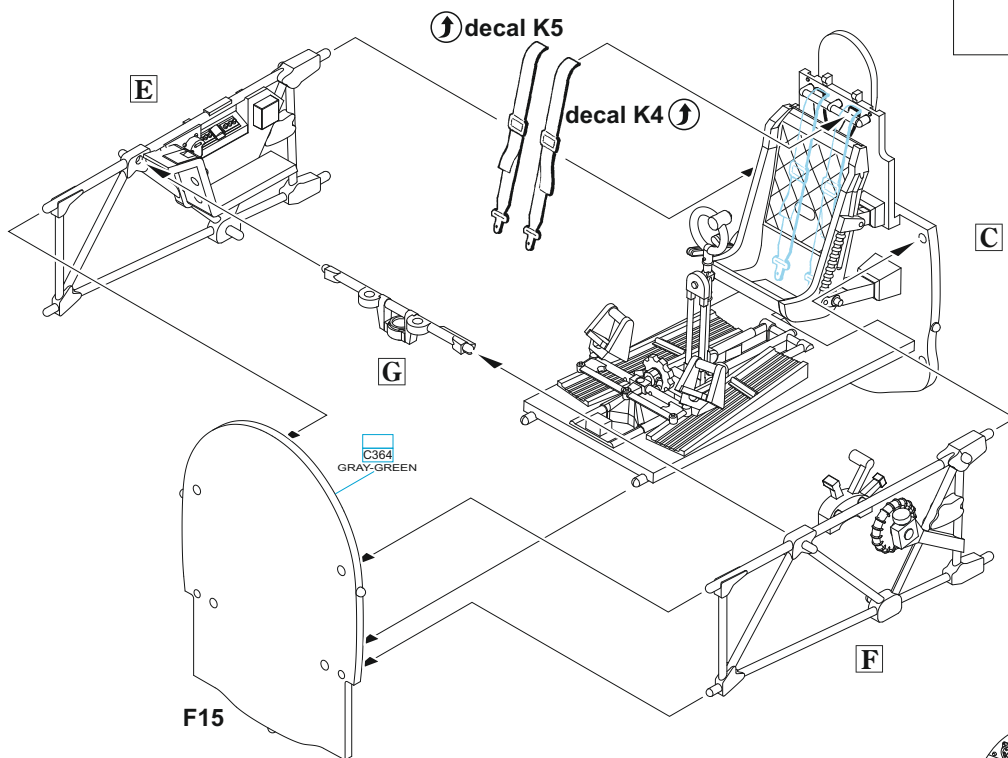
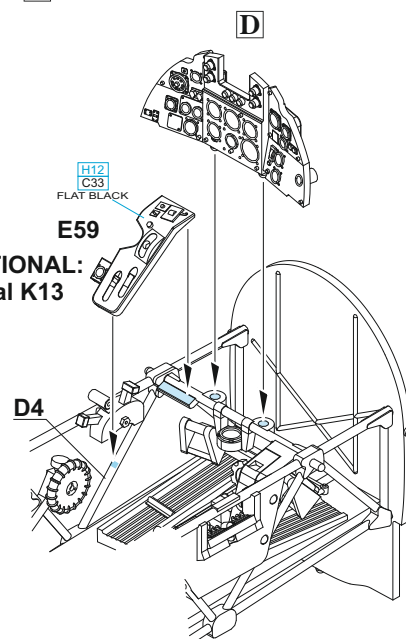
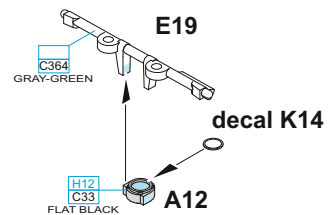
E**F****H****G**

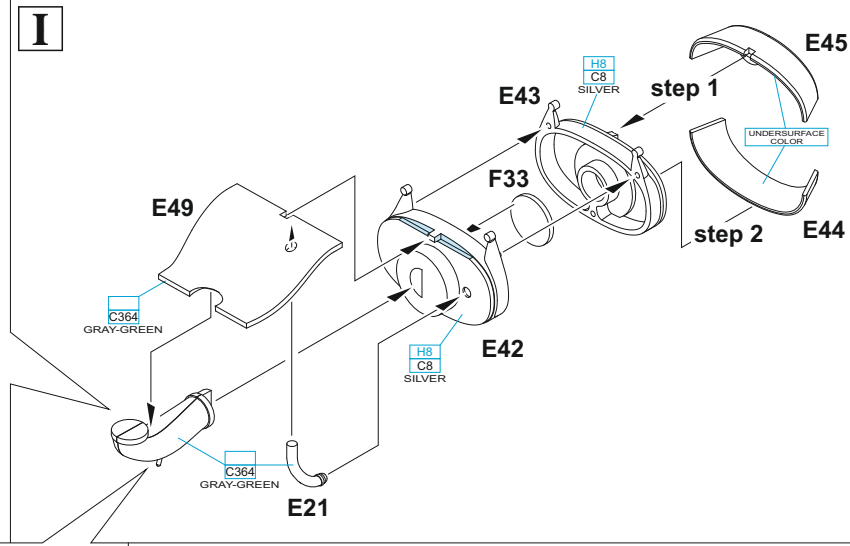
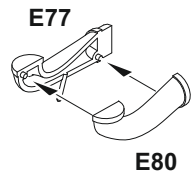
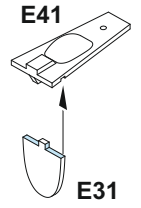
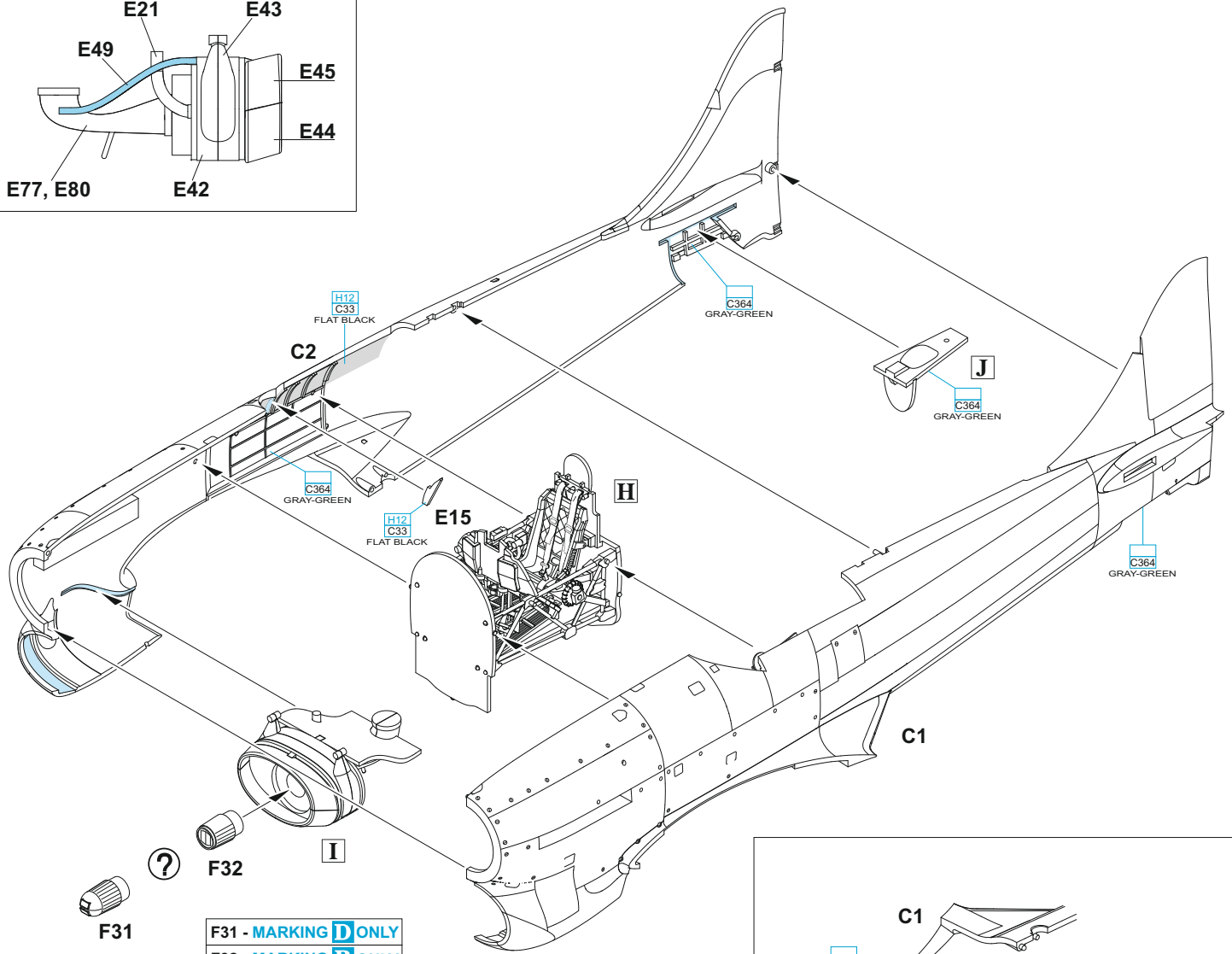
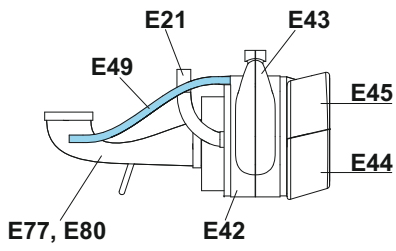
I**J****CROSS SECTION**

F31 - MARKING **D** ONLY
F32 - MARKING **B** ONLY

OPTIONAL:
decal K10

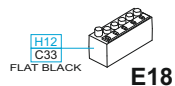

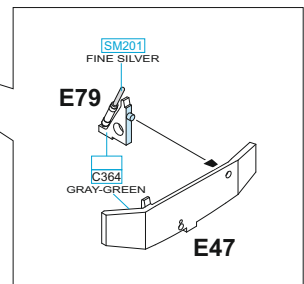
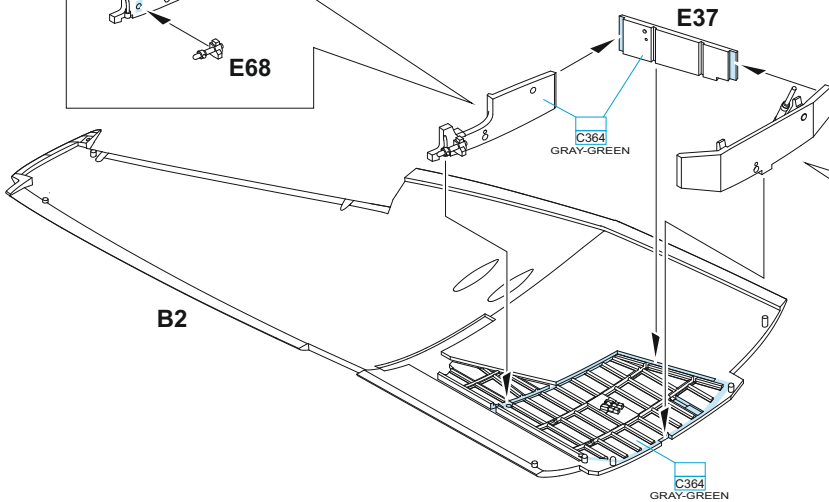
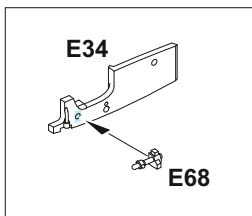
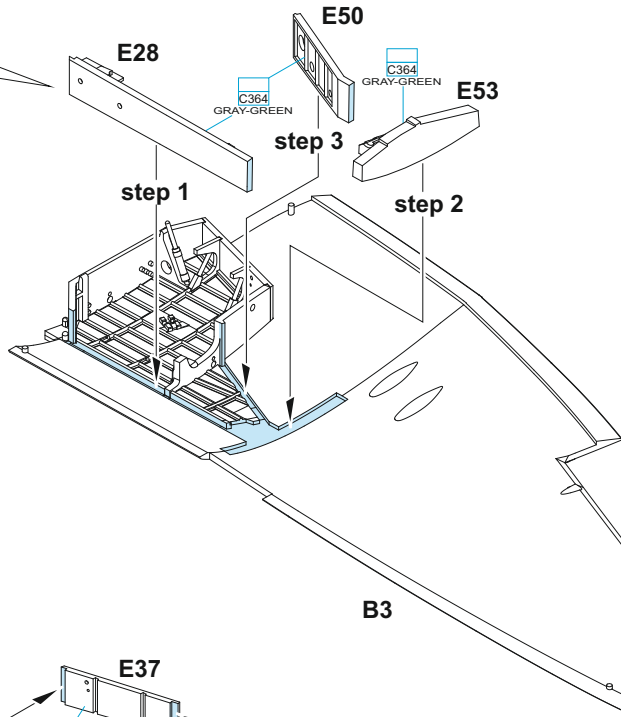
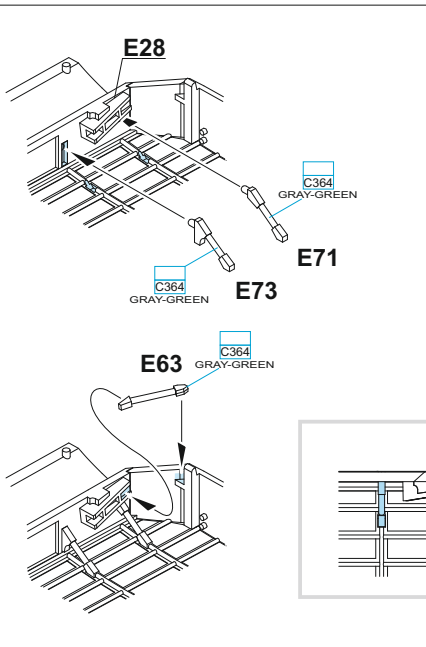
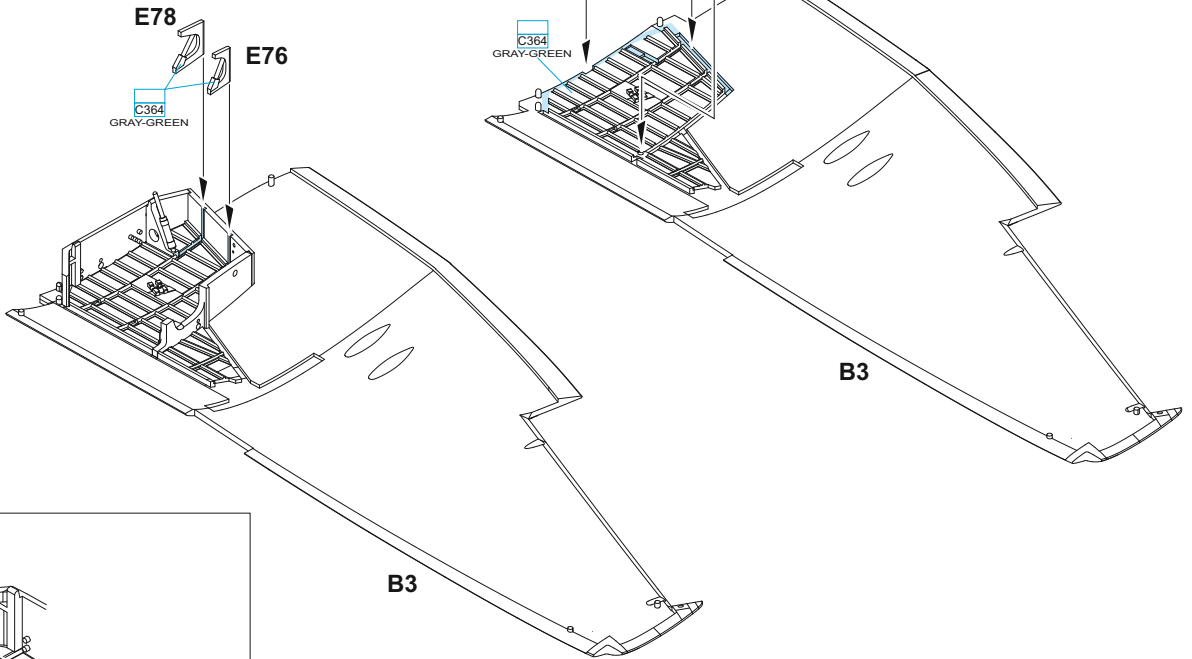
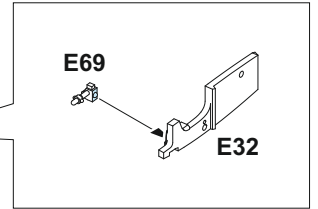
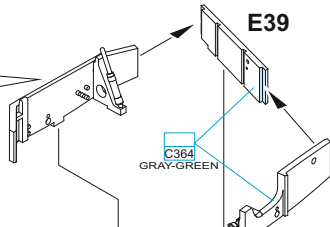
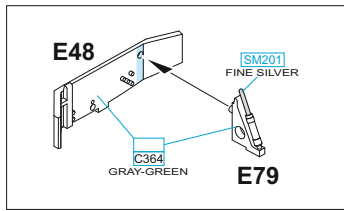

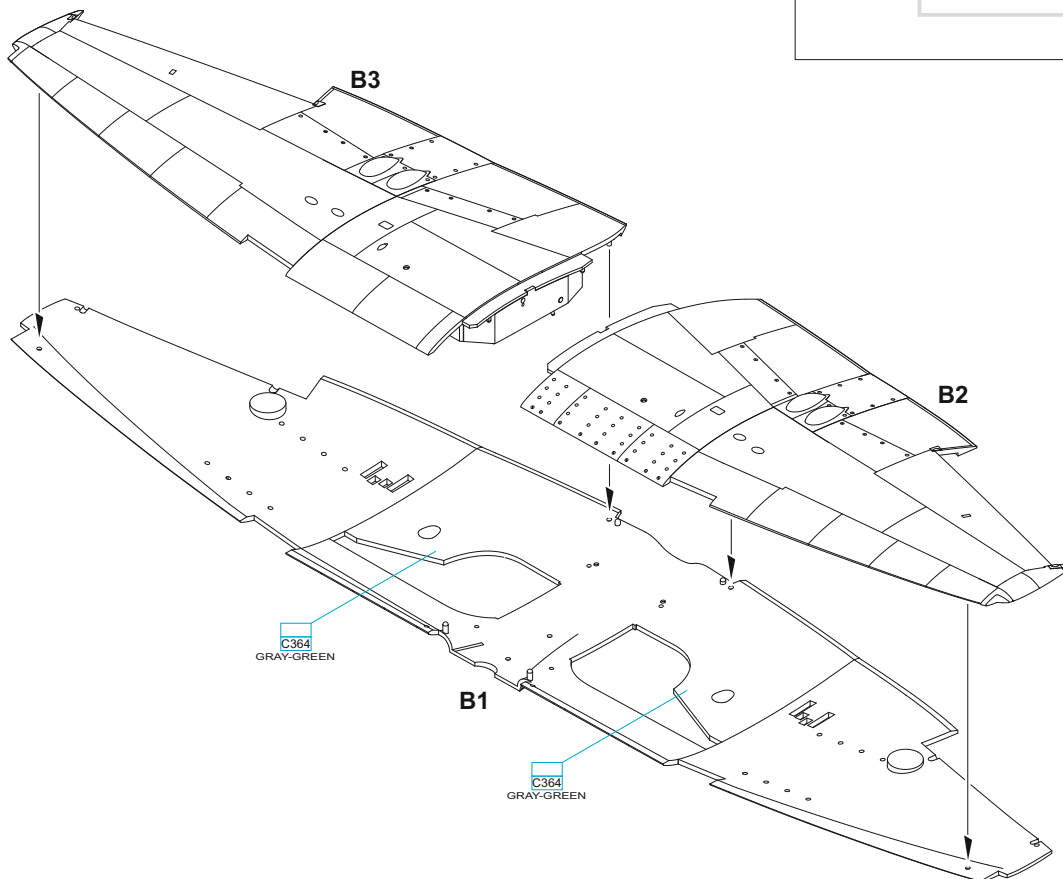
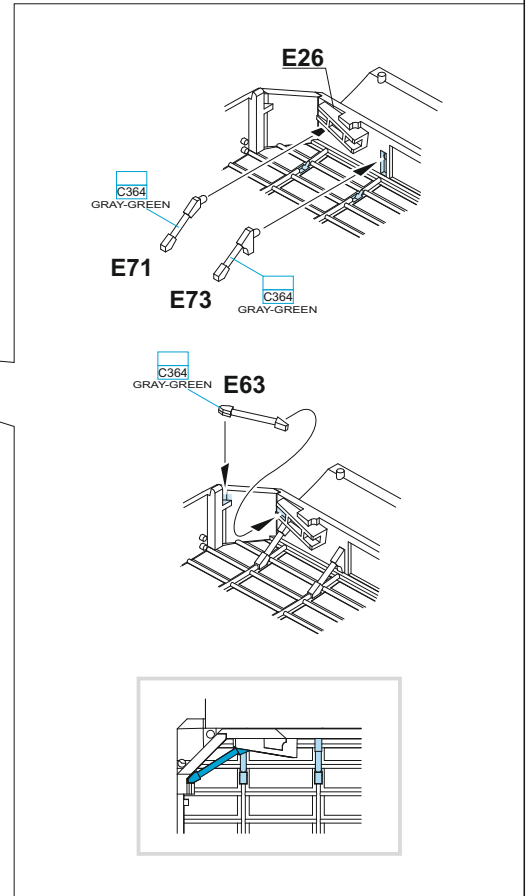
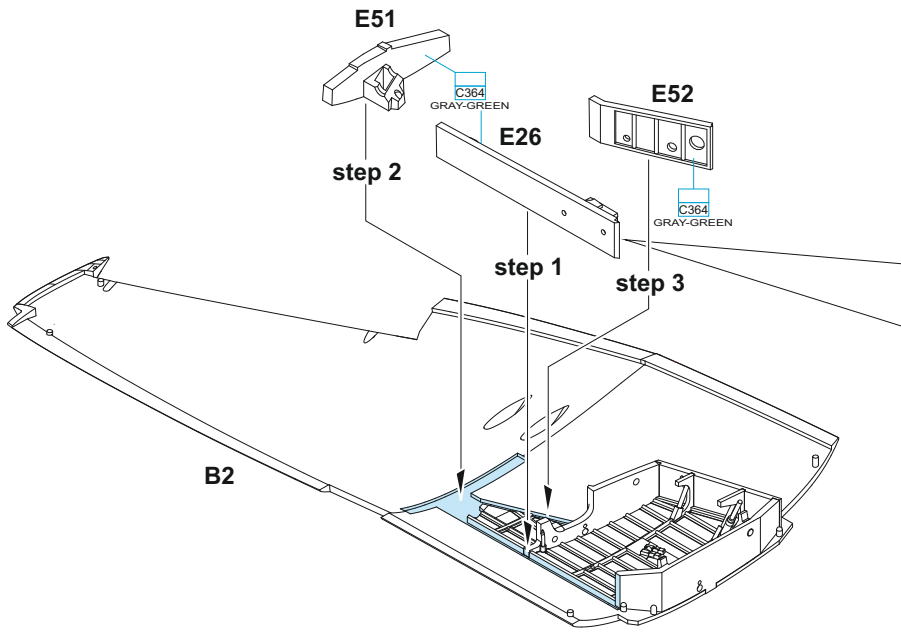
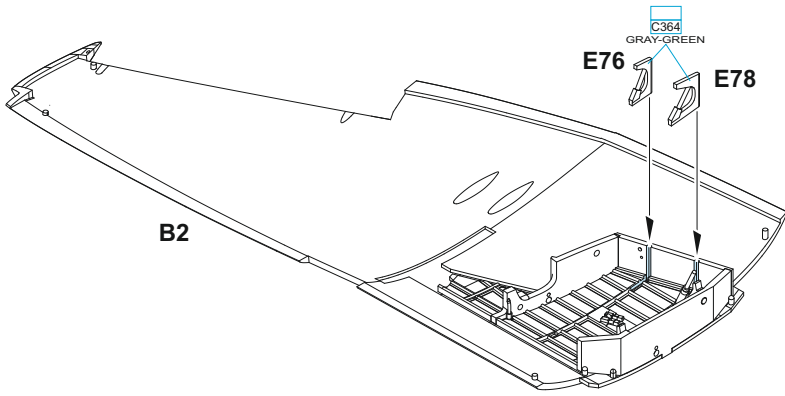

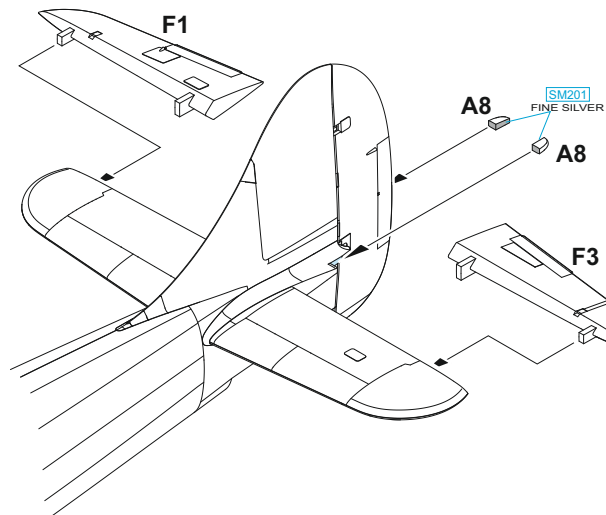
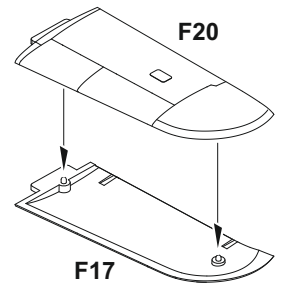
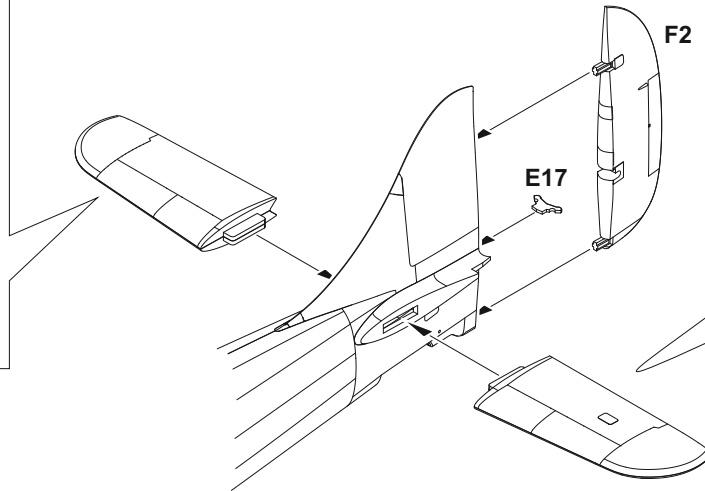
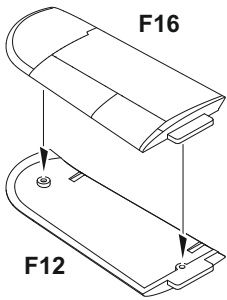
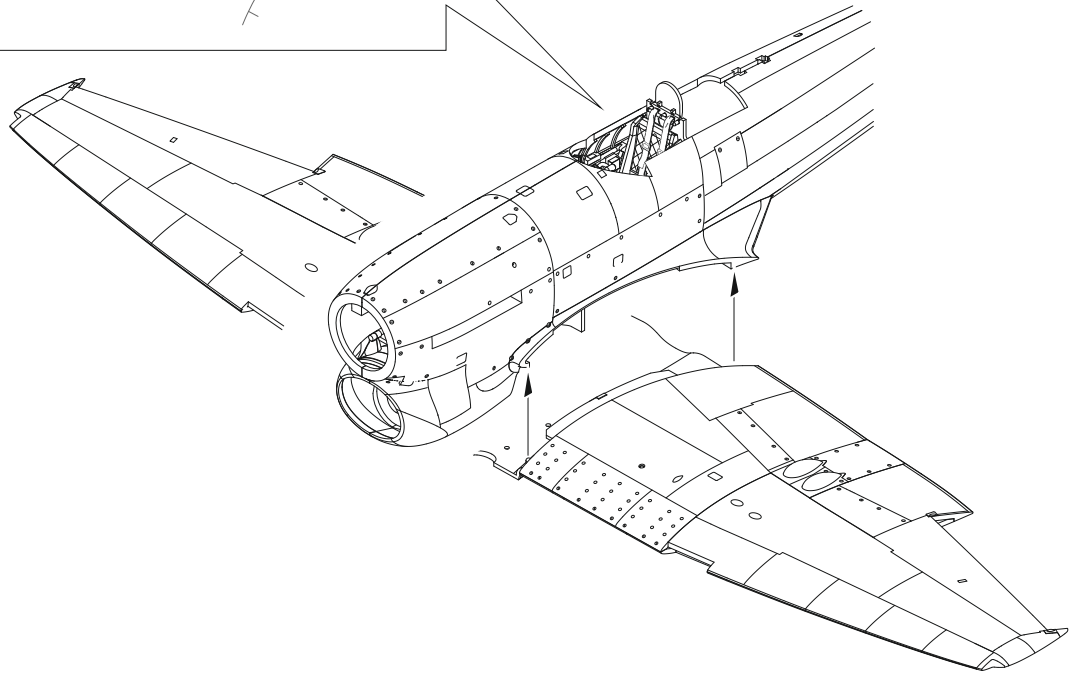
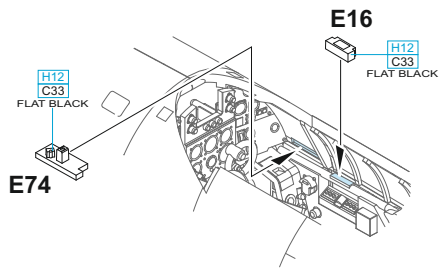

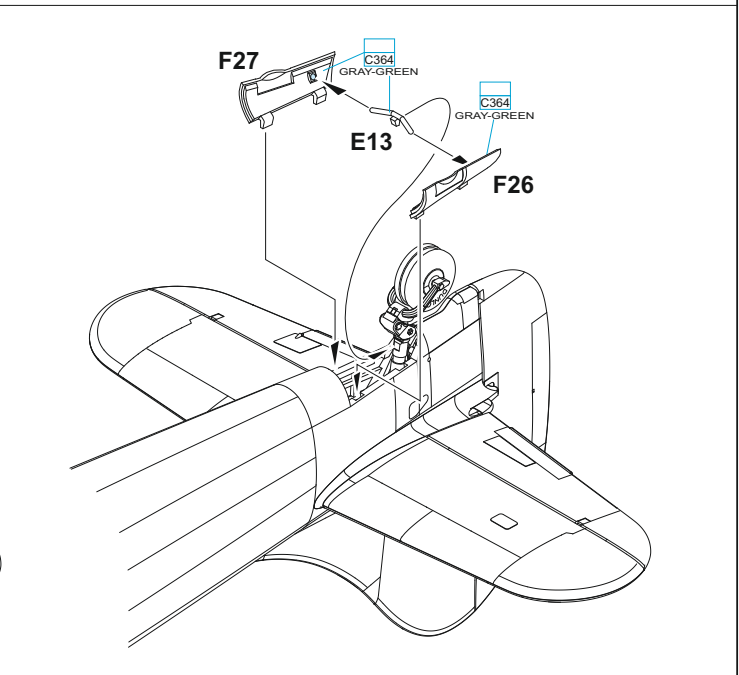
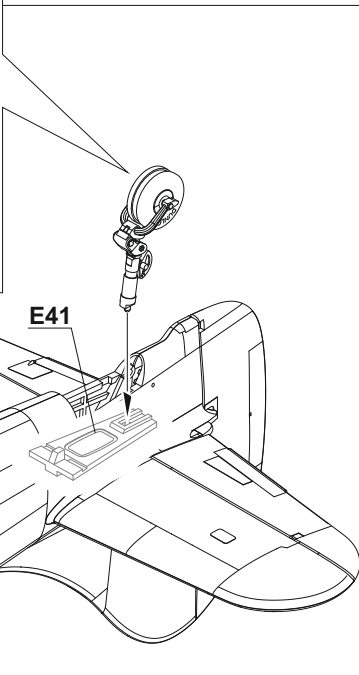
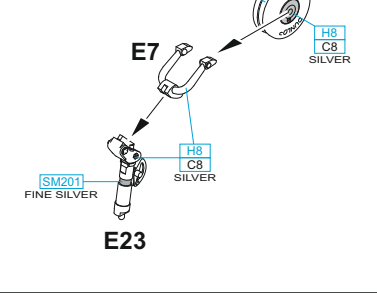
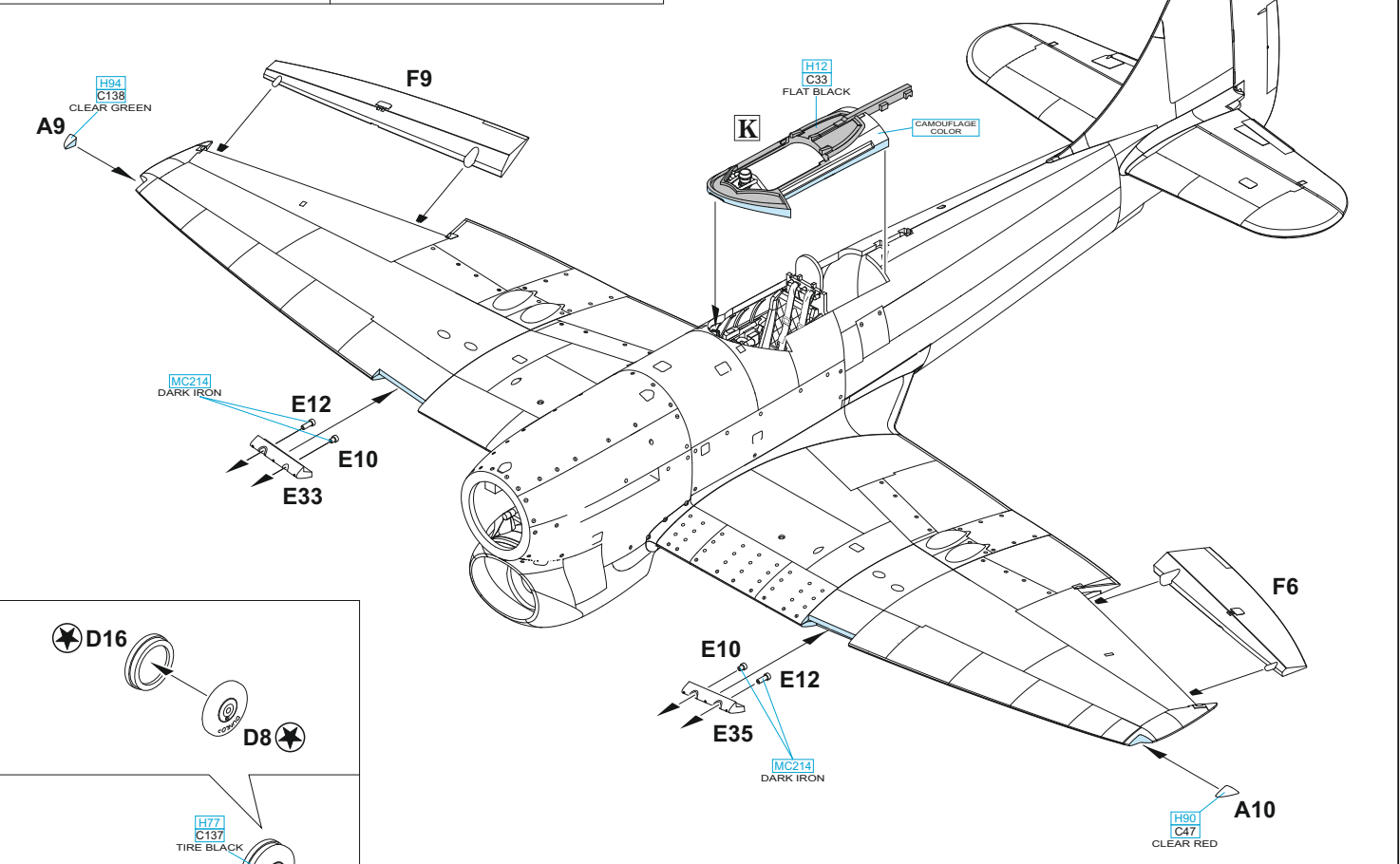
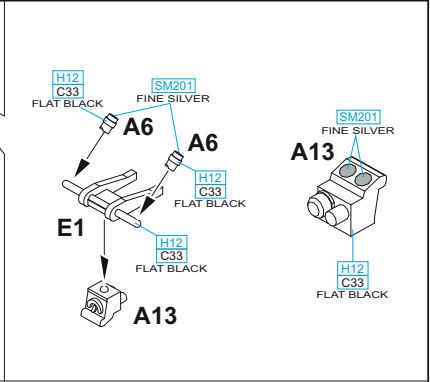
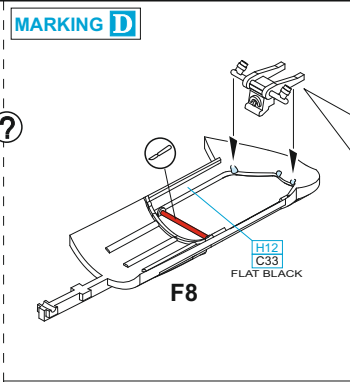
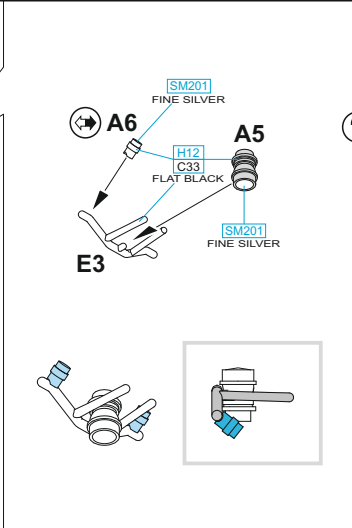
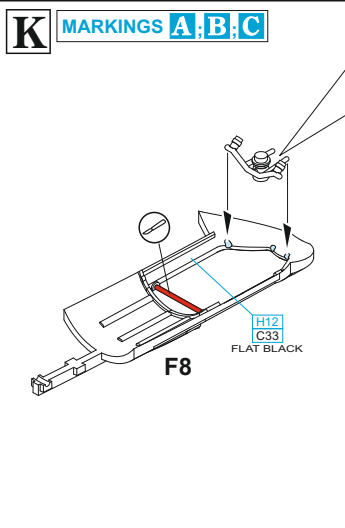

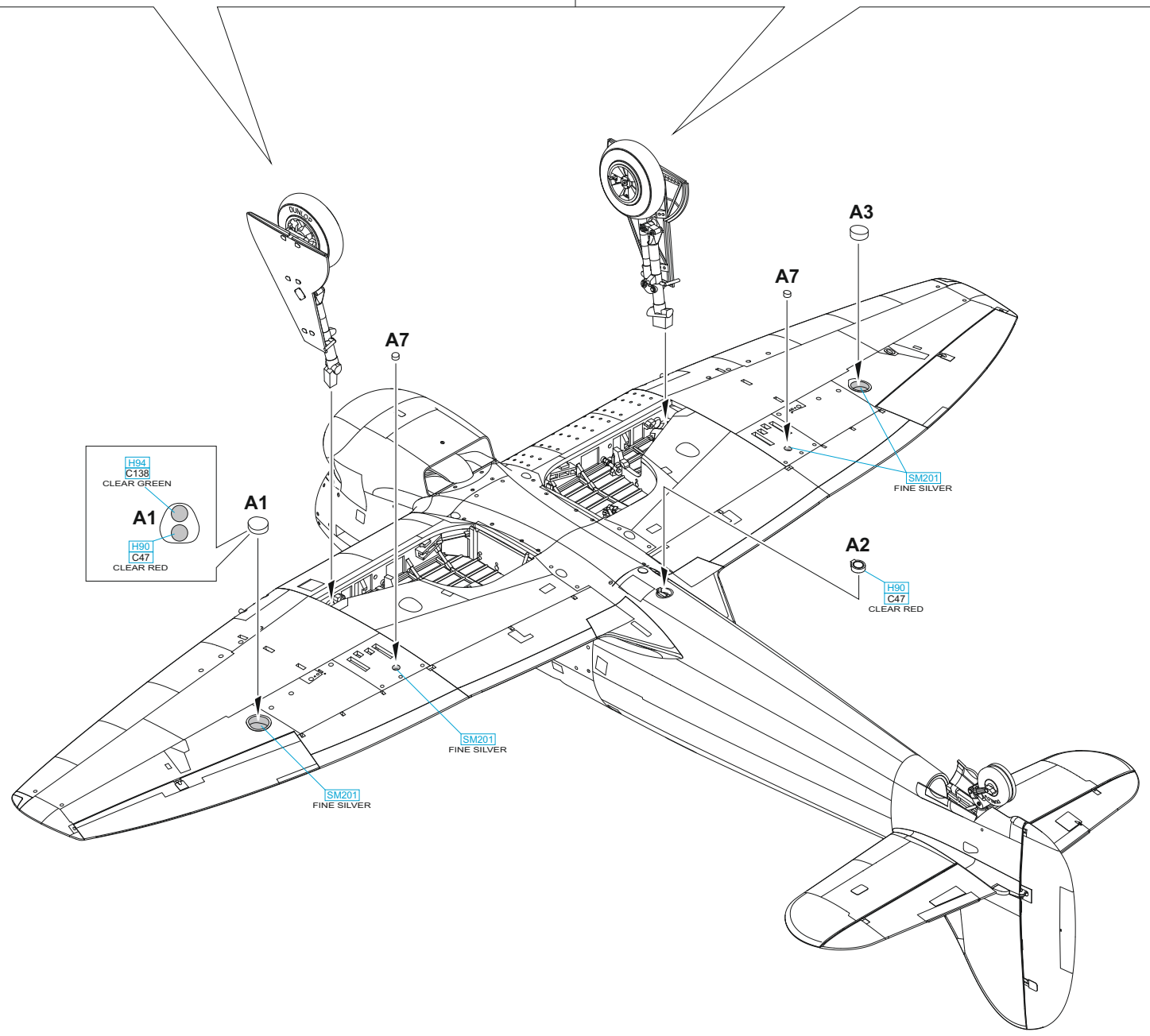
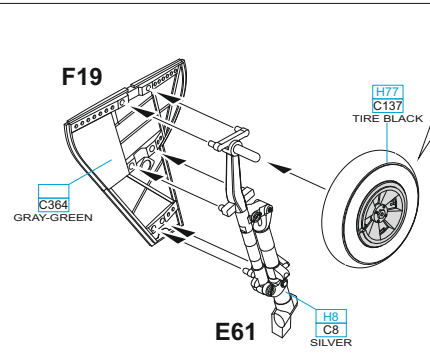
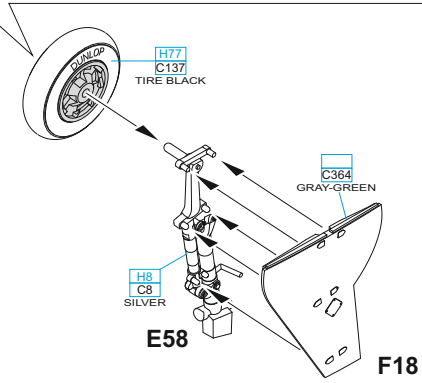
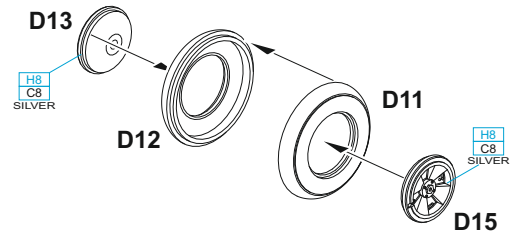
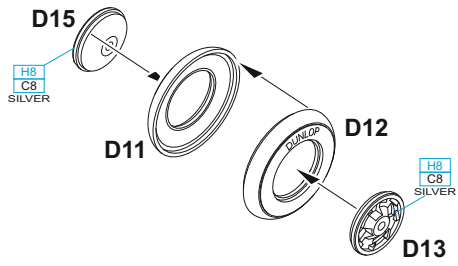

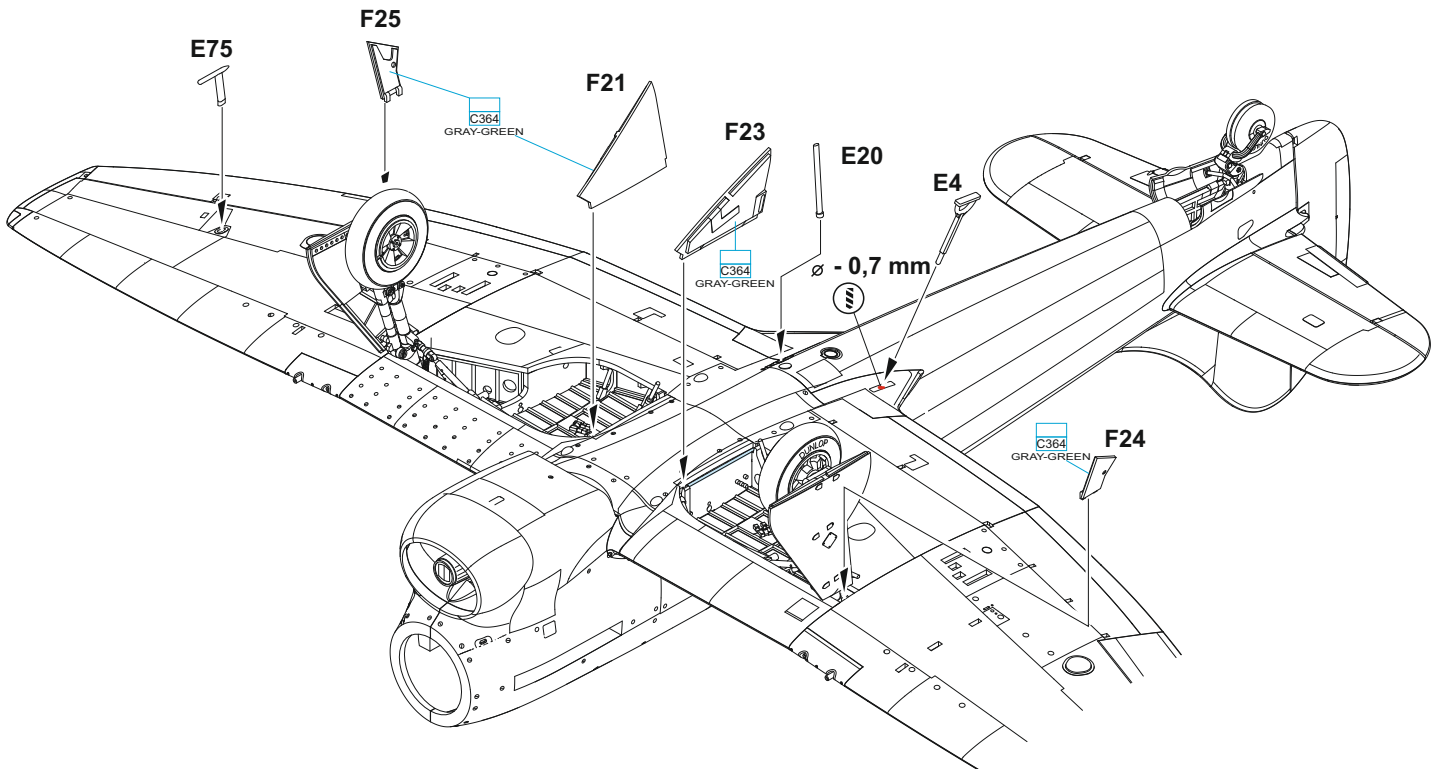
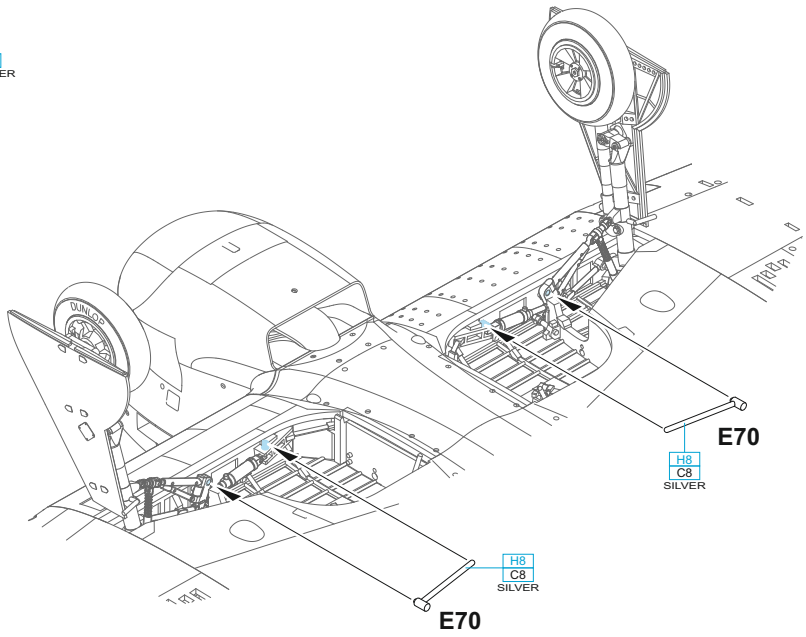
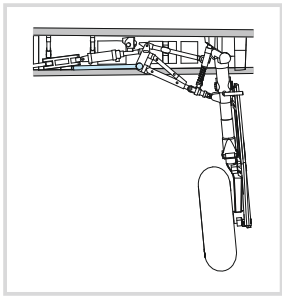
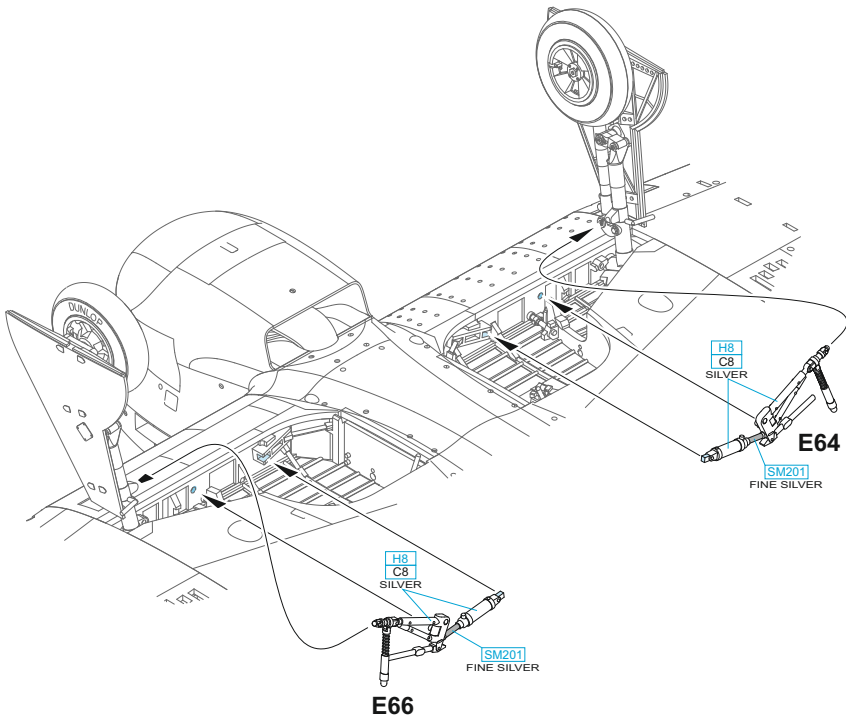

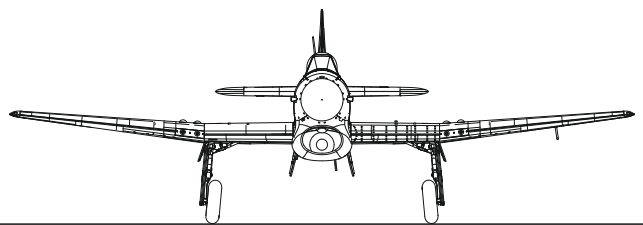
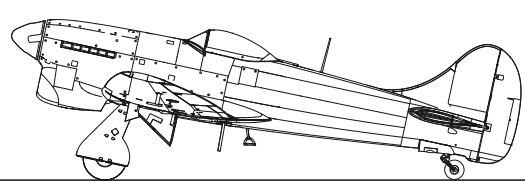
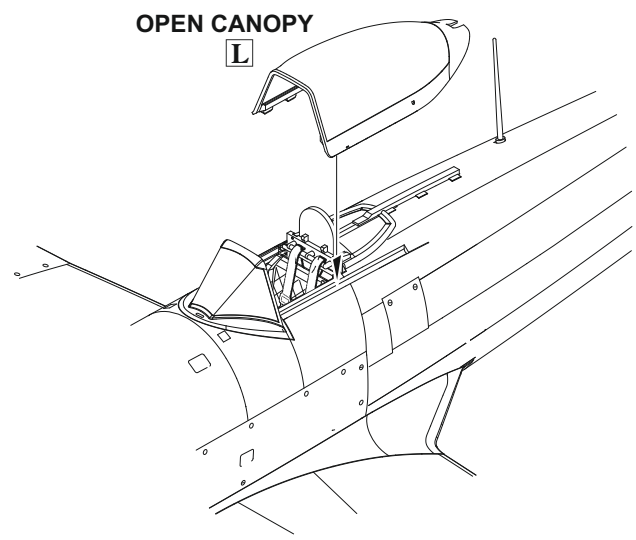
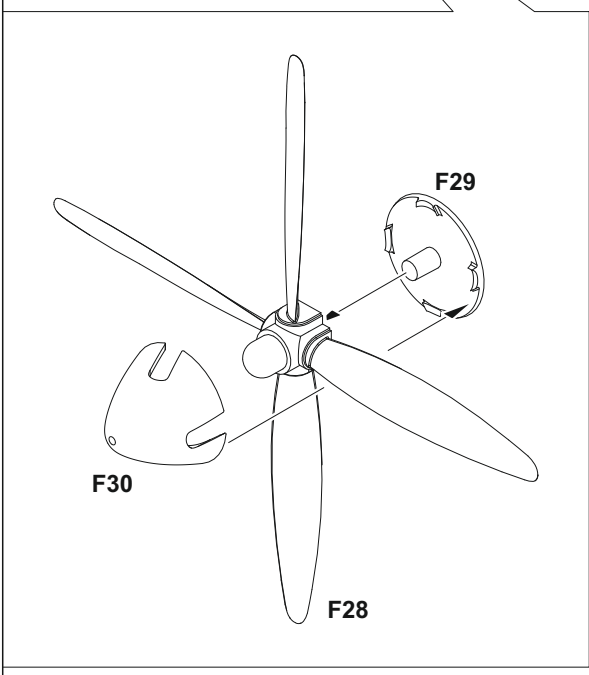
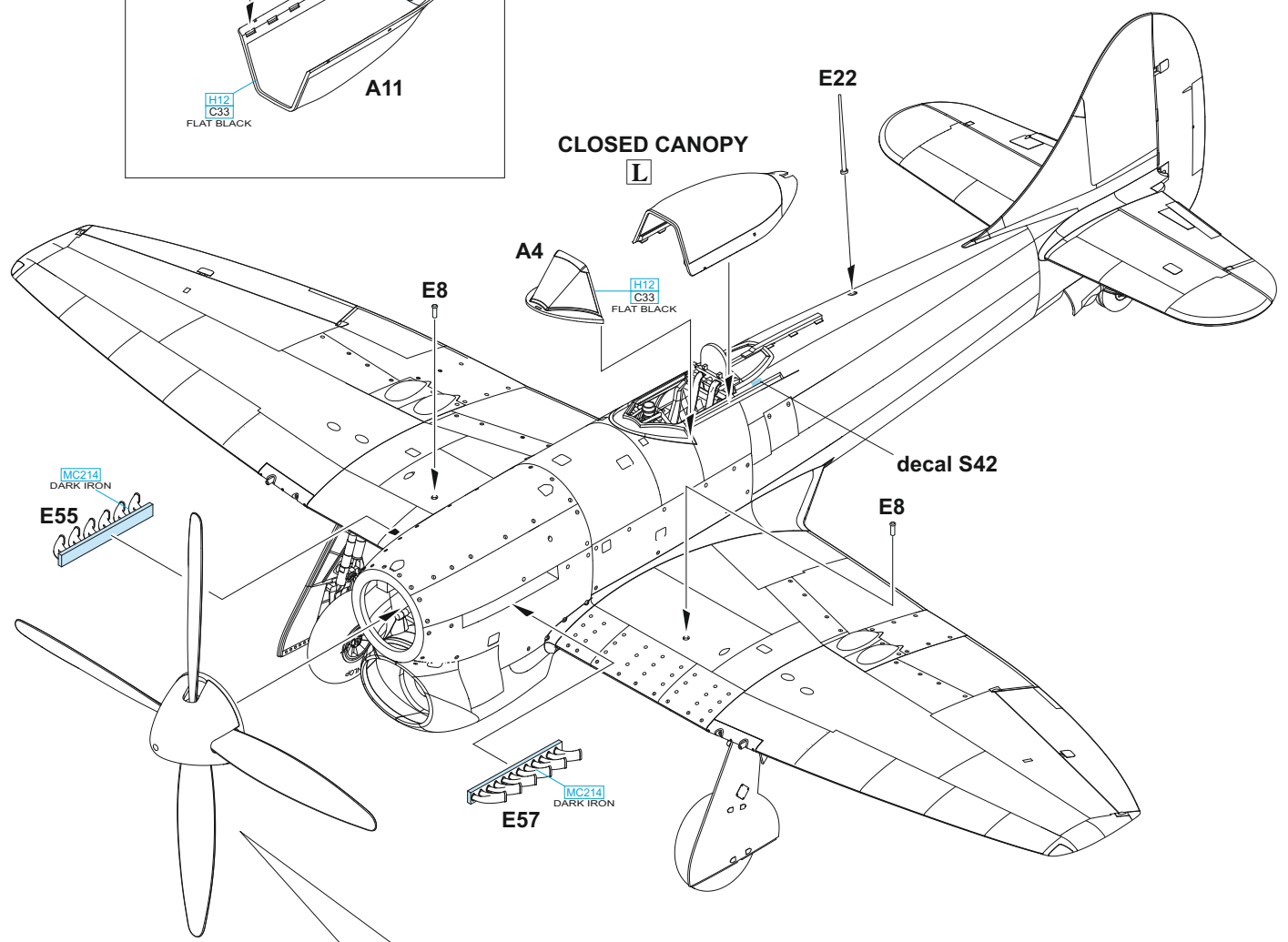
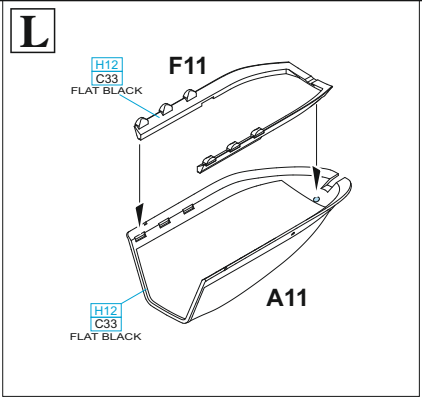

M ? MARKINGS **A**, **B**, **C** ONLY

N ? MARKINGS **A**, **B**, **C** ONLY

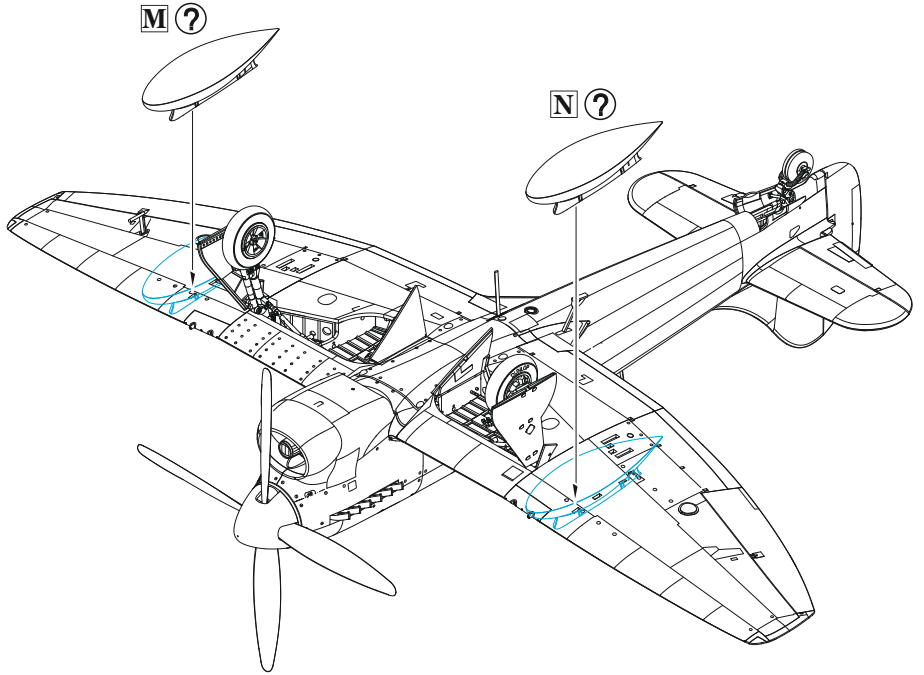
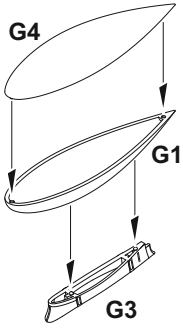
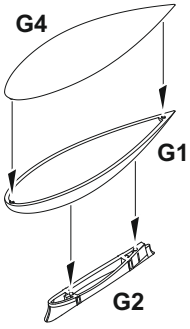

O 4 pcs.

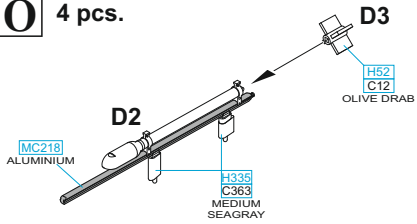

P 4 pcs.

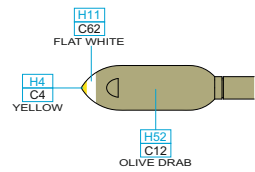
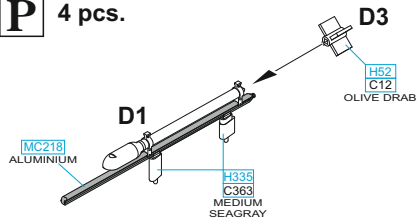

MARKING **D** ONLY

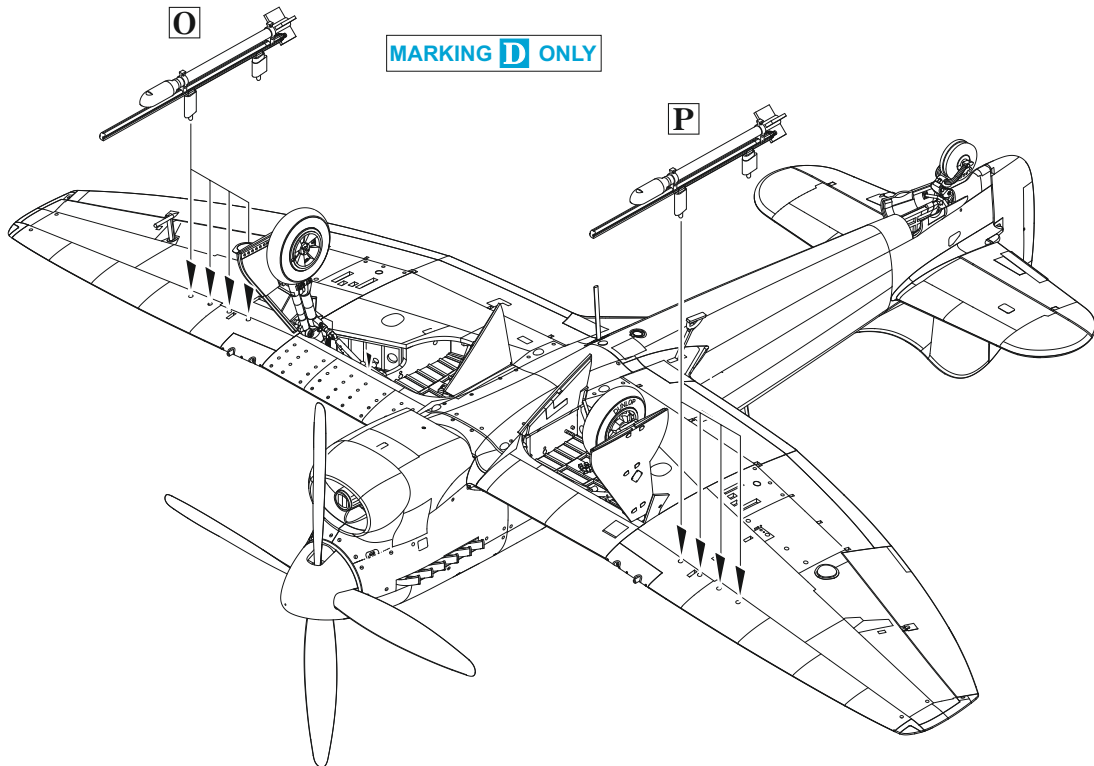

B EJ536, F/Lt Pierre H. Clostermann, No. 56 Squadron, B.80 Volkel, the Netherlands, beginning of April 1945

The well-known French pilot, F/Lt Pierre Henri Clostermann, flew with No. 56 Squadron from March 18 until April 5, 1945. His usual mount was initially a Tempest serial number EJ708 marked US-W, in the end of March it was replaced by a Tempest serial number EJ536 and on the fuselage it again carried the US-W code letters. On April 5, 1945, while at its controls, he damaged two Fw 190D-9s and destroyed four Ju 88Gs on the ground. On the starboard side under the windshield Clostermann had painted 16 crosses, symbols of his current air combat successes (in total 12 confirmed kills and four probables). He finished his combat career flying with No. 3 Squadron with the total score of 14 confirmed kills, four probables and nine enemy aircraft destroyed on the ground.

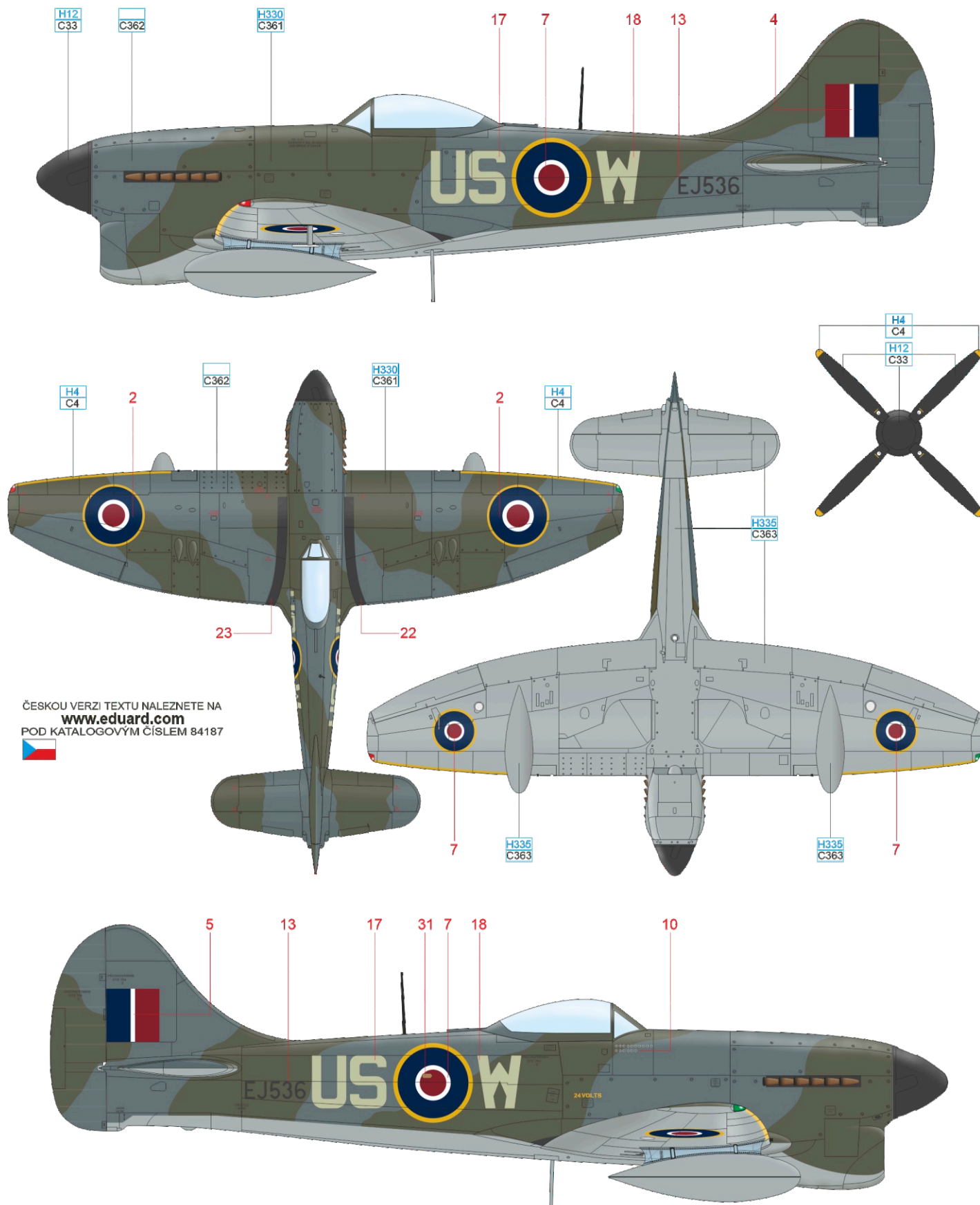

ČESKOU VERZI TEXTU NALEZNETE NA
www.eduard.com
 POD KATALOGOVÝM ČÍSLEM 84187

MEDIUM SEA GRAY H335 C363 DARK GREEN H330 C361 OCEAN GRAY C362 YELLOW H4 C4 BLACK H12 C33

D SN330, S/Ldr Colin H. Macfie, CO of No. 3 Squadron, Wunstorf, Germany, 2nd half of 1947

Tempest serial number SN330 missed the wartime service. In November 1945 it was dispatched to Germany and in January 1946 assigned to the No. 80 Squadron. During the following month it was damaged and returned to the Great Britain for repairs at Hawker company. After the repairs were completed, it was delivered to the No. 3 Squadron sporting the overall coat of the aluminum paint and new, type D cockades. J5-H code letters were painted in the unit's traditional green color. S/Ldr Colin Hamilton Macafie chose this aircraft as his commander's plane. In May 1948 the Tempests were replaced by Vampires F.1 and SN330 was returned to the Great Britain for storage. In November 1950 it was sent for the scrap metal.

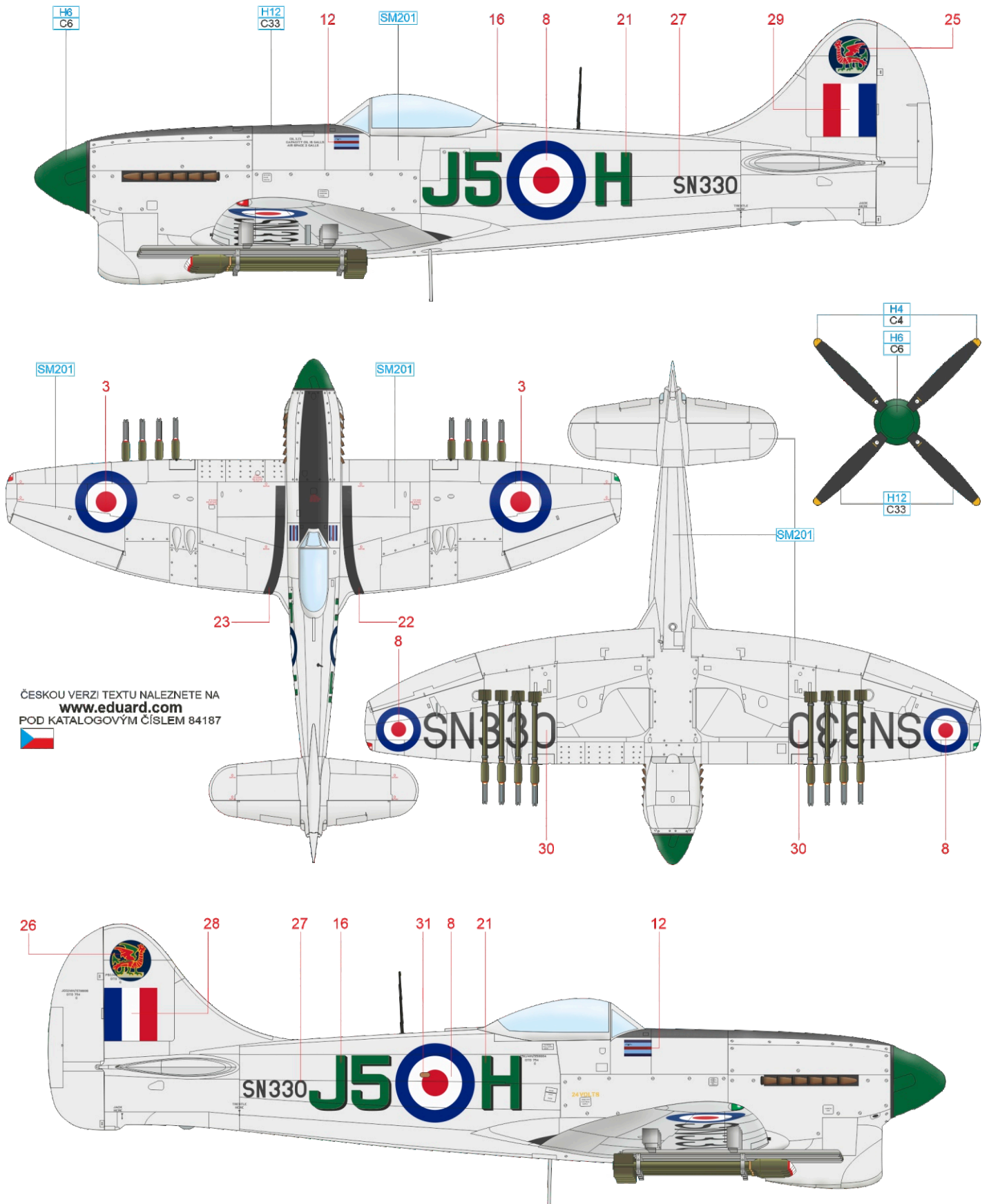

ČESKOU VERZI TEXTU NALEZNETE NA
www.eduard.com
 POD KATALOGOVÝM ČÍSLEM 84187

SUPER FINE SILVER SM201 GREEN H6 C6 YELLOW H4 C4 BLACK H12 C33

eduard

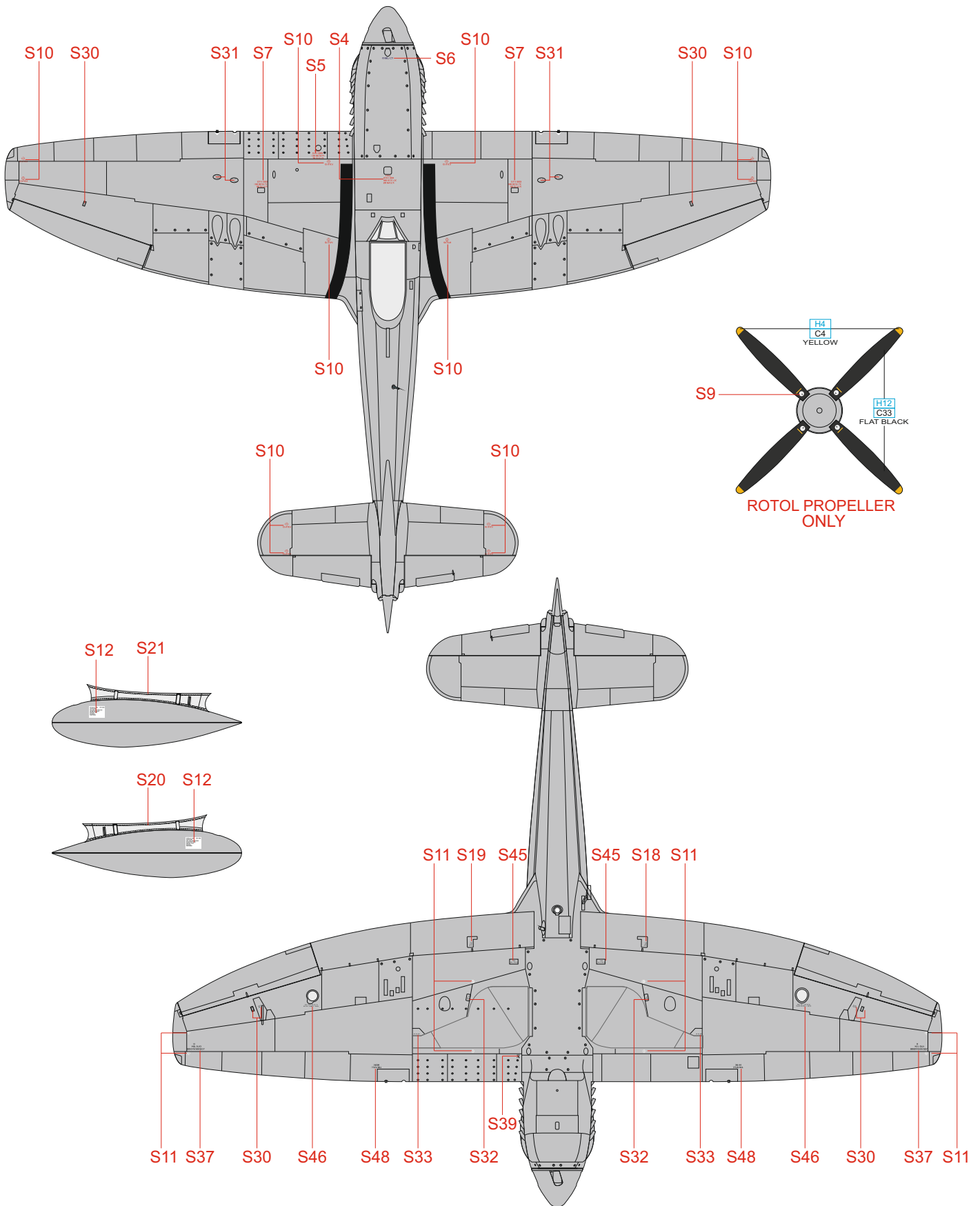

S52 S51 S50 S49

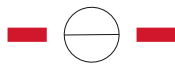
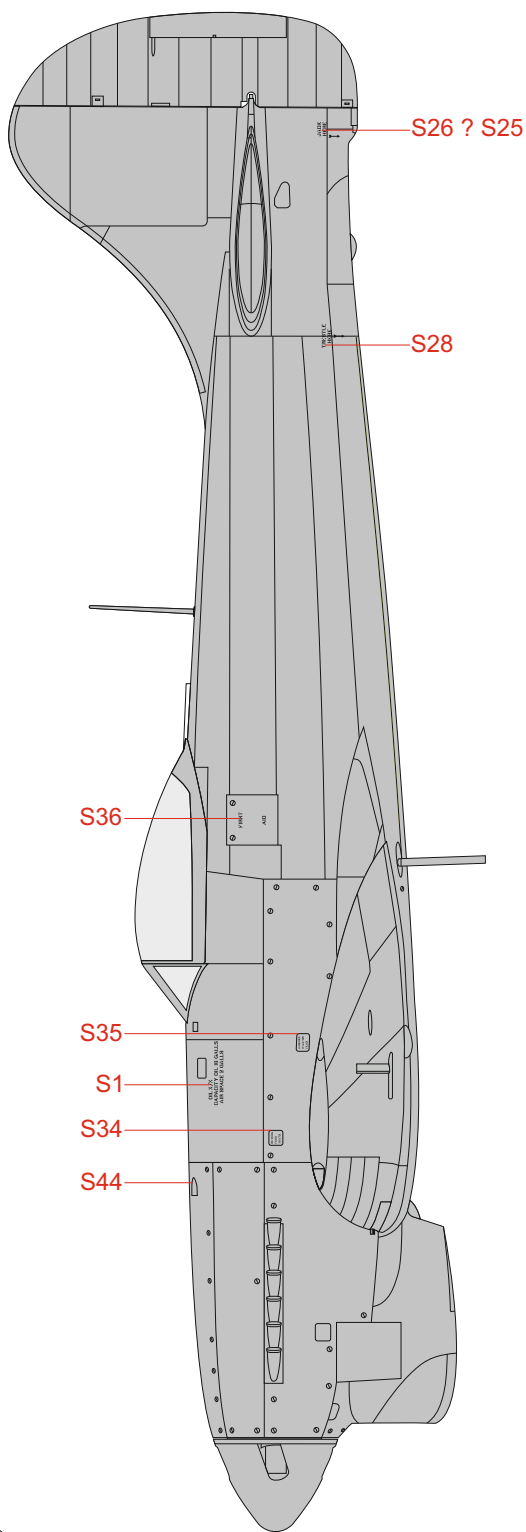
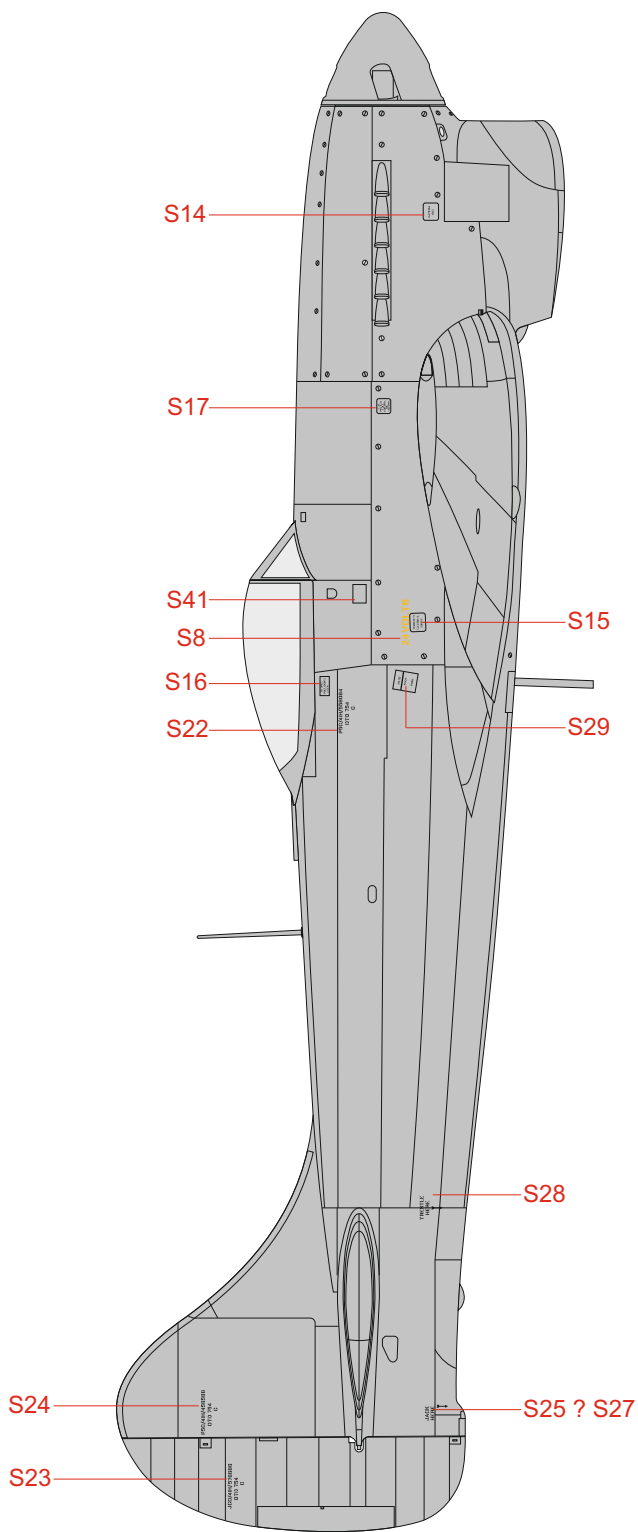

S47 - ALL „AMAL”
FASTENERS
ON THE WINGS AND
FUSELAGE

Eduard goodies for

Tempest Mk.V Series 2

1/48

- 48976 Tempest Mk.V upgrade set (PE-Set)
- 48977 Tempest Mk.V landing flaps (PE-Set)
- FE943 Tempest Mk.V seatbelts STEEL (PE-Set)
- FE1079 Tempest Mk.V series 2 Weekend (PE-Set)
- BIG49212 Tempest Mk.V (PE-Set)
- 644006 Tempest Mk.V LööK (Brassin)
- 644039 Tempest Mk.V w/ late wheels LööKplus (Brassin)
- 648416 Tempest Mk.V cockpit (Brassin)
- 648417 Tempest Mk.V engine (Brassin)
- 648418 Tempest Mk.V exhaust stacks (Brassin)
- 648419 Tempest Mk.V gun bays (Brassin)
- 648421 Tempest Mk.V wheels late (Brassin)
- 648446 Tempest Mk.V undercarriage legs BRONZE (Brassin)
- 648450 RP-3 60lb rockets for Tempest Mk.V (Brassin)
- 648499 Tempest Mk.V intake ring (Brassin)
- 648500 Tempest Mk.V dust filter w/ eyelid (Brassin)
- SIN64858 Tempest Mk.V ADVANCED (Brassin)
- 3DL48023 Tempest Mk.V SPACE (3D Decal Set)
- D48030 Tempest Mk.V stencils (Decal Set)
- EX628 Tempest Mk.V TFace (Mask)
- EX695 Tempest Mk.V (Mask)

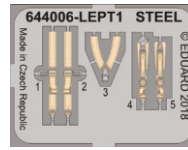

Cat. No. 644006



Cat. No. 648450

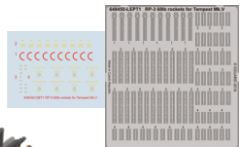
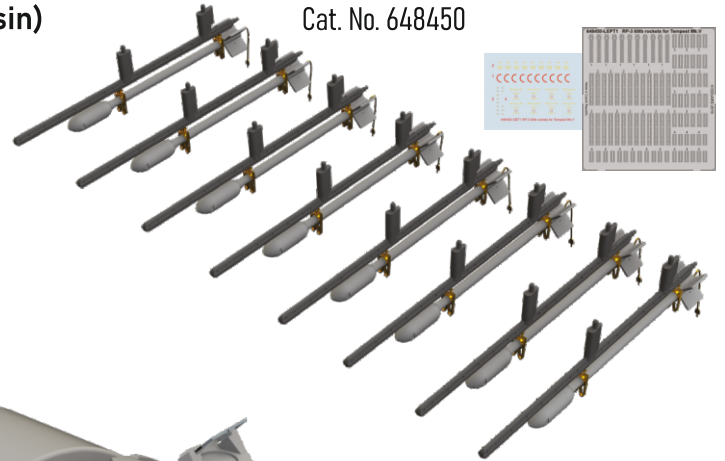

Cat. No. 648417

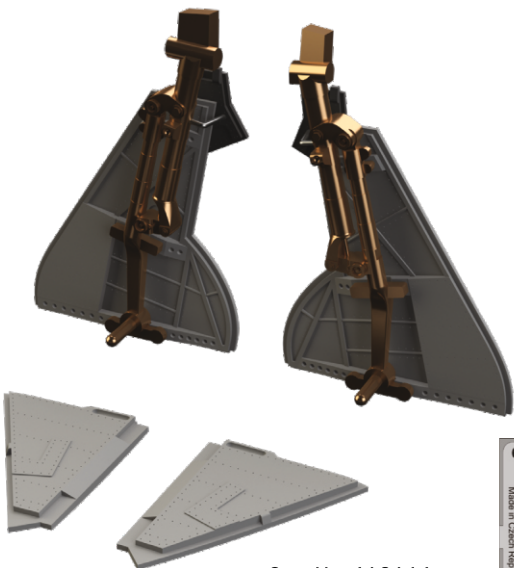
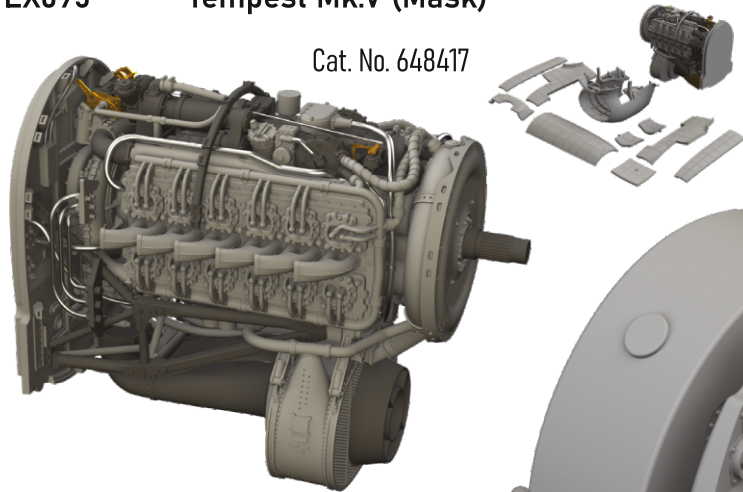

Cat. No. 648446

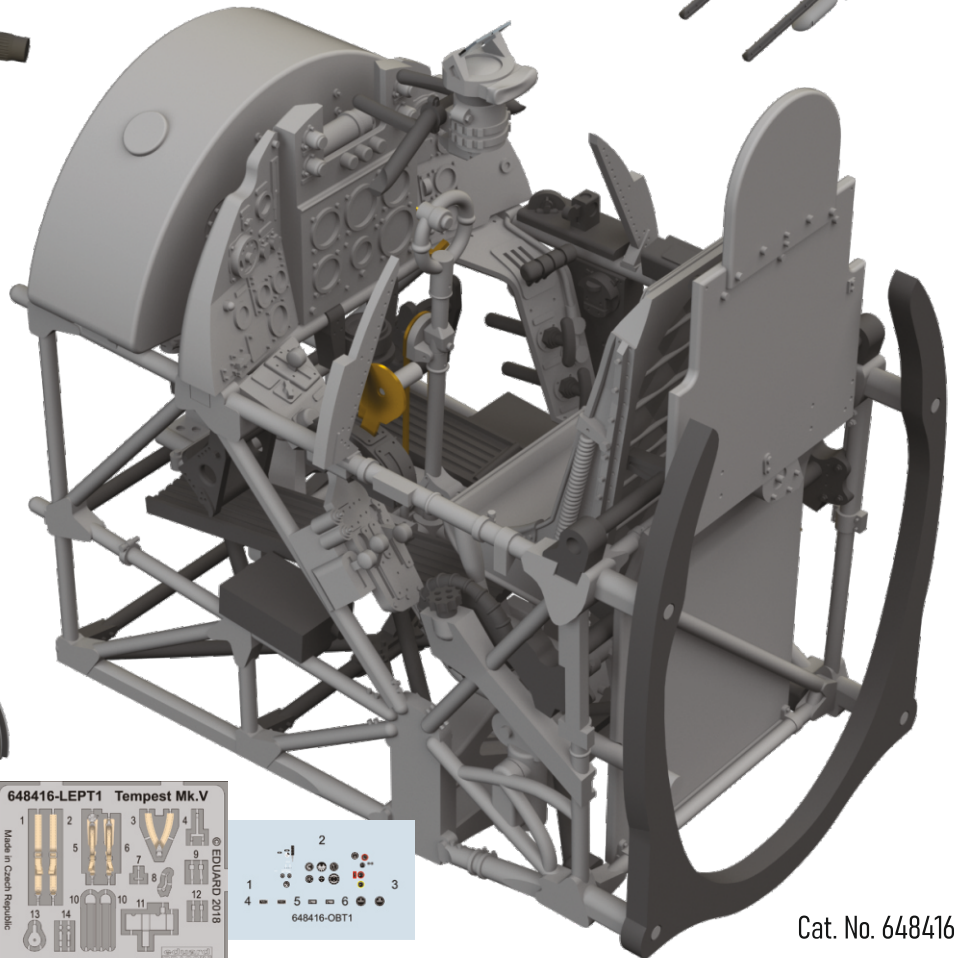
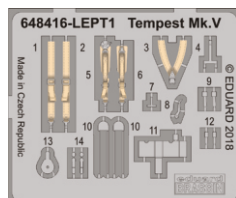

Cat. No. 648416