

U.S. WWII Heavy Bomber 1:72 SCALE PLASTIC KIT

eduard



intro

The Consolidated B-24 Liberator four-engined heavy bomber is one of WWII's flying legends. Along with another famous bomber, the Boeing B-17 Flying Fortress, it helped gain victory over the Third Reich, and in large numbers served on the other side of the world, against the Japanese armed forces.

The first prototype made its maiden flight on December 29, 1939 and more than 18,000 Liberators were built by the end of World War II. This number consists of many versions - bombers, recon and transport airplanes. Mass production was undertaken in five assembly plants and at its peak produced up to 650 aircraft per month. The assembly plants were operated by Consolidated in San Diego and Fort Worth, by Ford in Willow Run, by Douglas in Tulsa, and by North American, also in Dallas.

Apart of the US air forces, the Liberator was flown by air forces of other nations. The Royal Air Force obtained around 2100 aircraft. Approximately 1600 of them were B-24H, J and L models, the latter being redesignated by the British as Liberator VI / VIII. These aircraft were supplied under the Lend-Lease agreement between the spring of 1944 and August of 1945.

Mission Centenarians – this patriotic label belongs to bombers that have completed one hundred missions over enemy territory. In terms of operational and non-operational losses, the milestone was significant and not possible without a constant supply of spares. For example, 'THE BLUE STREAK' received over the course of its service life, nineteen new engines, two wings and a replaced tail section. This much work, and repairs conducted on bullet holes and shrapnel damage, naturally had an impact on the look of the aircraft.

Such notable accomplishments of these machines demanded fully taking advantage of military resources. Famous aircraft then would find their way back to the United States and take part in mustering support through the War Bond Tours, by which the American government was able to support its war effort. For these purposes, the aircraft were often adorned with 'modeler friendly' marking schemes.

This kit offers you three such machines. 'CHUG-A-LUG', 'MOBY DICK' and 'THE BLUE STREAK', adorned with nose art, a long line of mission markers, destroyed aircraft and ships, and inscriptions, are offered to hopefully give the best selection of subjects without requiring any other modifications. The selections chosen were inevitable – Liberators went through a long list of modifications, including different types of turrets. The fourth aircraft – 'THE VULGAR VIRGIN' – fits the theme of this release very well, despite not actually achieving the century mission mark.

úvodem

Těžký čtyřmotorový bombardér Consolidated B-24 Liberator se nesmazatelně zapsal do dějin leteckých bojů v období 2. světové války. Po boku neméně proslulého typu Boeing B-17 Flying Fortress pomáhal porazit německou Třetí říši, ve velkých počtech válčil také na druhé straně zeměkoule, proti japonským ozbrojeným silám.

První prototyp vzletl dne 29. prosince 1939 a do konce války se podařilo postavit přes 18 000 exemplářů. Tento počet zahrnoval řadu verzí nejrůznějšího zaměření. Od bombardérů, přes průzkumné stroje až po letouny dopravní. Masová výroba postupně naběhla v pěti továrnách a v roce 1944 se podařilo dosáhnout měsíční produkce až 650 kusů. Podílely na ní dvě továrny společnosti Consolidated (San Diego a Fort Worth) a též licenční výroba u Fordu ve Willow Run, u North American v Dallasu a u Douglasu v Tulse.

Kromě amerických ozbrojených sil jej do své výzbroje zařadily další státy – Velkou Británii nevyjímaje. Do řad RAF se dostalo okolo 2100 exemplářů.

Mission Centenarians – toto čestné pojmenování patří bombardérům, které absolvovaly více než 100 bojových letů proti nepříteli. V kontextu operačních i neoperačních ztrát se jednalo o úctyhodný výkon, mnohdy podepřený slušnou řádkou náhradních dílů. Například „The Blue Streak“ dostal během své bojové kariéry 19 nových motorů, dvě poloviny křídla, vyměněny byl i ocasní plochy. Náročný provoz a nutnost opravovat otvory po kulkách a střepinách vyslaných nepřitelem se pochopitelně podepsali také na vzhledu stroje.

Výjimečné výkony strojů přímo volaly po využití v podpoře válečného úsilí. Slavné letouny tedy putovaly zpět do Spojených států. Zde byly ústředními postavami propagačních turné na podporu prodeje válečných obligací – War Bond Tour, jejichž prostřednictvím americká vláda získávala finanční prostředky na chod válečného hospodářství. Při této příležitosti stroje dostaly atraktivní marking, který z nich dělá vděčný objekt modelářského zájmu.

V této stavebnici vám přinášíme tři takové stroje. CHUG-A-LUG, MOBY DICK a THE BLUE STREAK, vyzdobeny nose-arty, dlouhou řádkou symbolů misí, zničených letadel a lodí a též nespočetnými nápisy, byly vybrány tak, abyste je mohli bez dalších velkých úprav postavit přímo z výlisků. Pečlivý výběr byl nezbytný – Liberatory procházely poměrně velkou řadou úprav, včetně zástavby různých střeleckých věží. Čtvrtý stroj – THE VULGAR VIRGIN – tento výběr krásou zbarvení a markingu dobře doplňuje, byť se sta odlétaných misí nedočkal.

E B-24D-15-CO, s/n 41-24047, 90th BG, 320th BS, Southwest Pacific, 1943

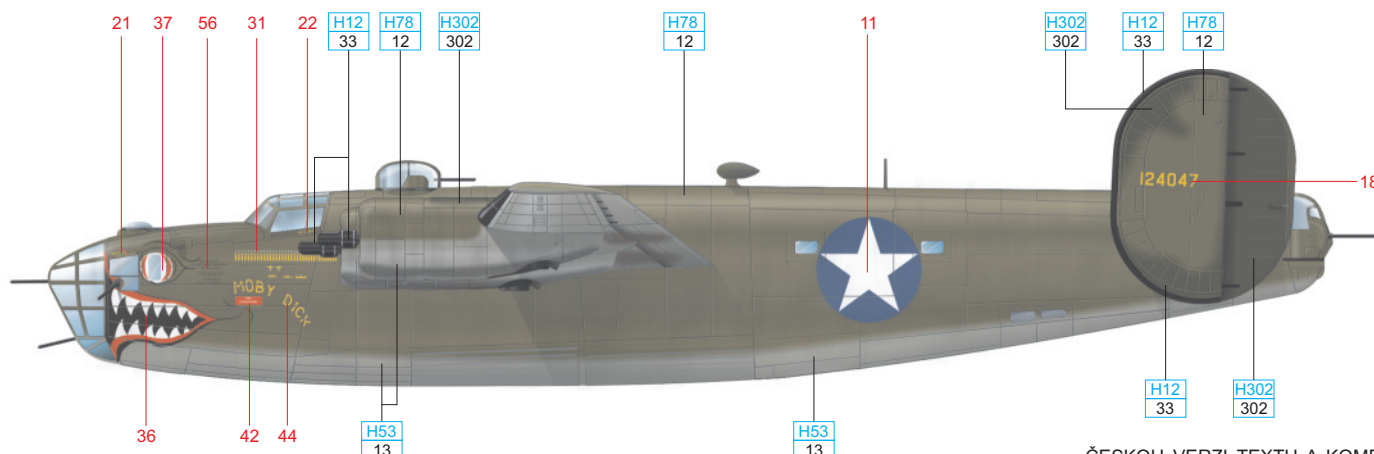

ATTENTION



UPOZORNĚNÍ



ACHTUNG



ATTENTION



注意



Carefully read instruction sheet before assembling. When you use glue or paint, do not use near open flame and use in well ventilated room. Keep out of reach of small children. Children must not be allowed to suck any part, or pull vinyl bag over the head.



Před započetím stavby si pečlivě prostudujte stavební návod. Při používání barev a lepidel pracujte v dobře vetrané místnosti. Lepidla ani barvy nepoužívejte v blízkosti otevřeného ohně. Model není určen malým dětem, mohlo by dojít k požití drobných dílů.



lire soigneusement la fiche d'instructions avant d'assembler. Ne pas utiliser de colle ou de peinture à proximité d'une flamme nue, et aérer la pièce de temps en temps. Garder hors de portée des enfants en bas âge. Ne pas laisser les enfants mettre en bouche ou sucer les pièces, ou passer un sachet vinyl sur la tête.



Von dem Zusammensetzen die Bauanleitung gut durchlesen. Kleber und Farbe nicht nahe von offenem Feuer verwenden und das Fenster von Zeit zu Zeit Belüftung öffnen. Bausatz von kleinen Kindern fernhalten. Verhüten Sie, daß Kinder irgendwelche Bauteile in den Mund nehmen oder Plastiktüten über den Kopf ziehen.



組み立てる前に必ず説明書をお読み下さい。接着剤や塗料をご使用の際は、窓を開けて十分な換気をおこない、火のそばでは使用しないで下さい。小さな子供の手の届かない所に必ず保管してください。部品や破片を噛んだり、なめたり、飲んだりすると大変危険です。又、部品を取り出した後のビニール袋は、小さな子供が頭から被ったりすると窒息する恐れがありますので、破り捨ててください。

INSTRUCTION SIGNS * INSTR. SYMBOLY * INSTRUKTION SINNBILDEN * SYMBOLES * 記号の説明



OPTIONAL
VOLBA
FACULTATIF
NACH BELIEBEN
選択する



BEND
OHNOUT
PLIER SIL VOUS PLAIT
BITTE BIEGEN
折る



OPEN HOLE
VYVRTAT OTVOR
FAIRE UN TROU
OFFNEN
穴を開ける



SYMETRICAL ASSEMBLY
SYMETRICKÁ MONTÁŽ
MONTAGE SYMÉTRIQUE
SYMMETRISCHE AUFBAU
左右均等に組み立てる



NOTCH
ZÁŘEZ
L INCISION
DER EINSCHNITT
切る



REMOVE
ODŘÍZNOUT
RETIRER
ENTFERNEN
移す



APPLY EDUARD MASK
AND PAINT
POUŽIT EDUARD MASK
NABARVIT

PARTS



DÍLY



TEILE



PIÈCES



部品

PLASTIC PARTS

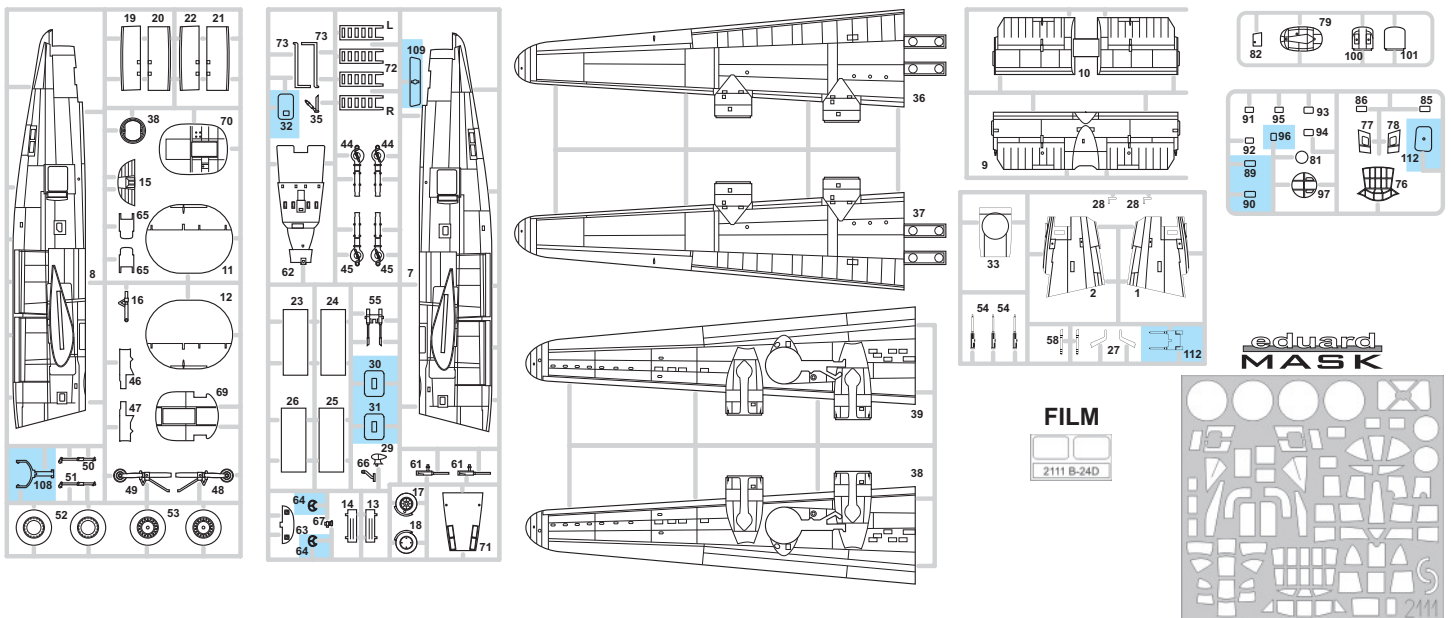
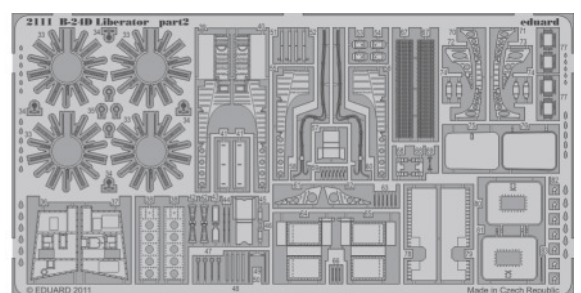
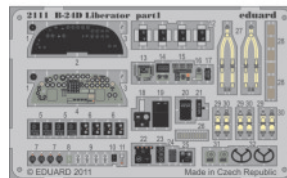
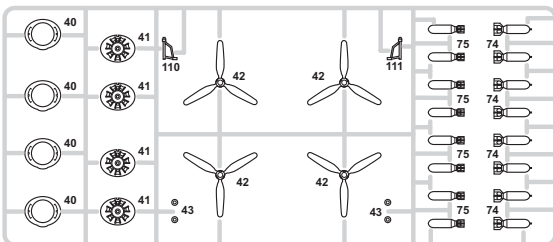
PE - PHOTO ETCHED
DETAIL PARTS

-Parts not for use. -Teile werden nicht verwendet. -Pièces à ne pas utiliser. -Tyto díly nepoužívejte při stavbě. - 使用しない部品

COLOURS



BARVY



FARBEN



PEINTURE



色

GSI Creos (GUNZE)		
AQUEOUS	Mr.COLOR	
H 4	C4	YELLOW
H 8	C8	SILVER
H 12	C33	FLAT BLACK
H 18	C28	STEEL
H 52	C12	OLIVE DRAB
H 53	C13	NEUTRAL GRAY
H 58		INTERIOR GREEN
H 67	C115	LIGHT BLUE
H 77	C137	TIRE BLACK

GSI Creos (GUNZE)		
AQUEOUS	Mr.COLOR	
H 78	C12	OLIVE DRAB
H 79	C39	SAND
H 302	C302	GREEN
H 344		RUST
	C27	INTERIOR GREEN
Mr.METAL COLOR		
	MC214	DARK IRON
	MC215	COPPER

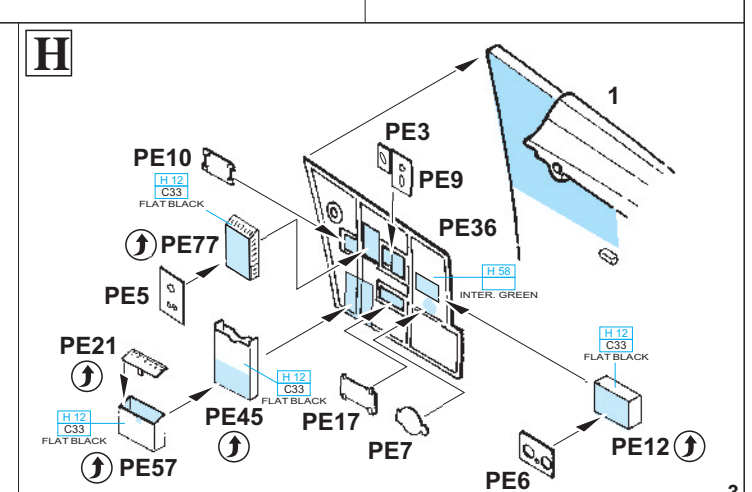
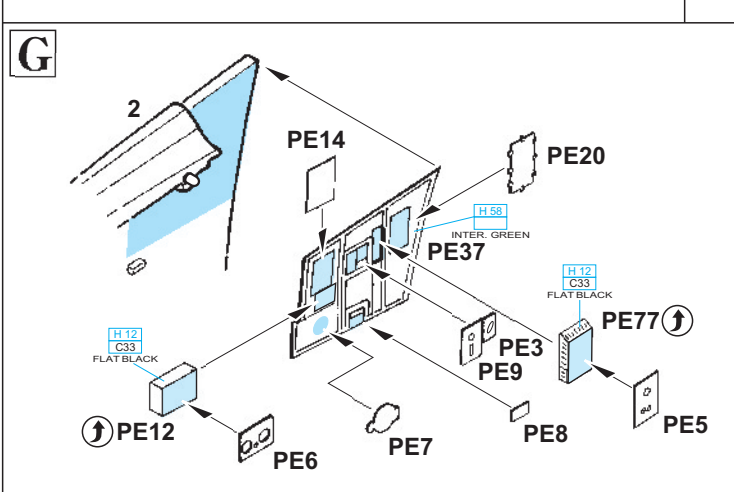
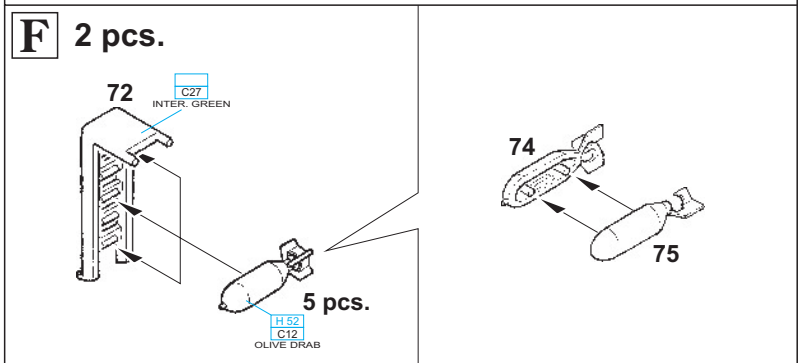
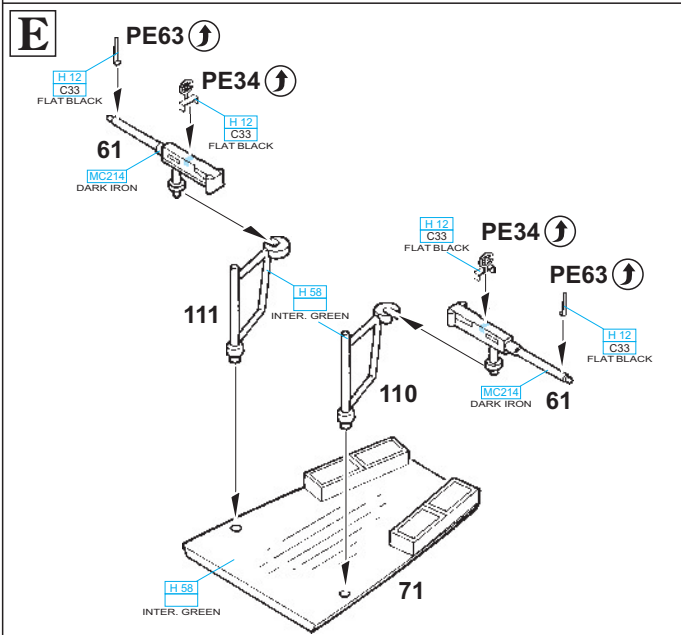
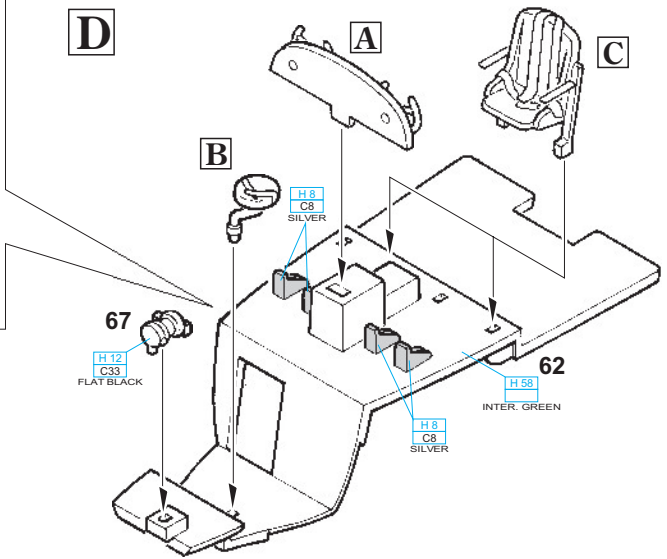
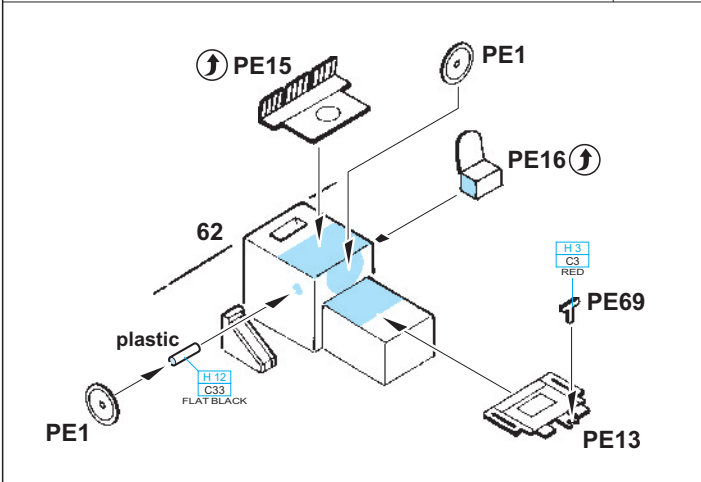
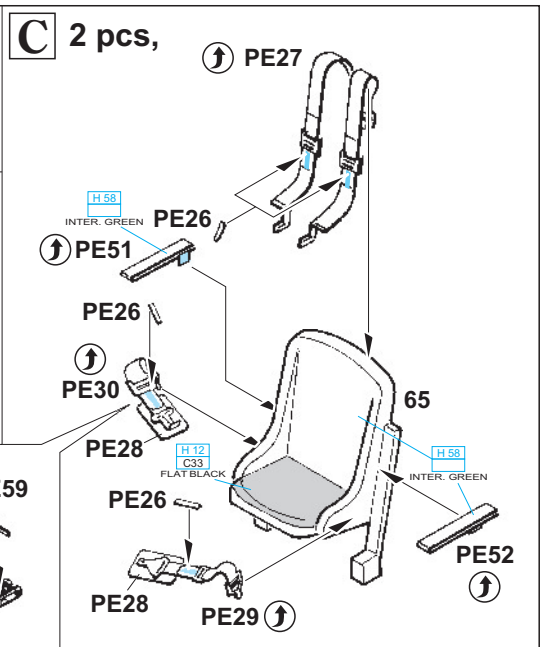
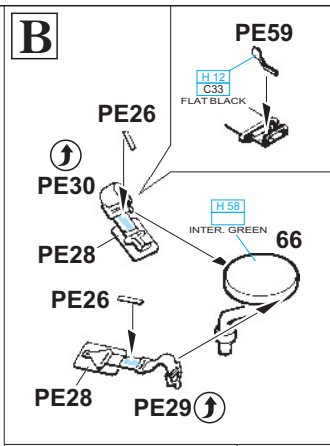
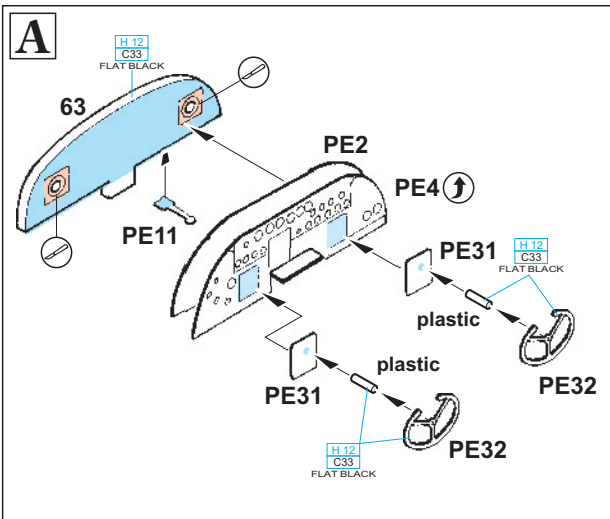

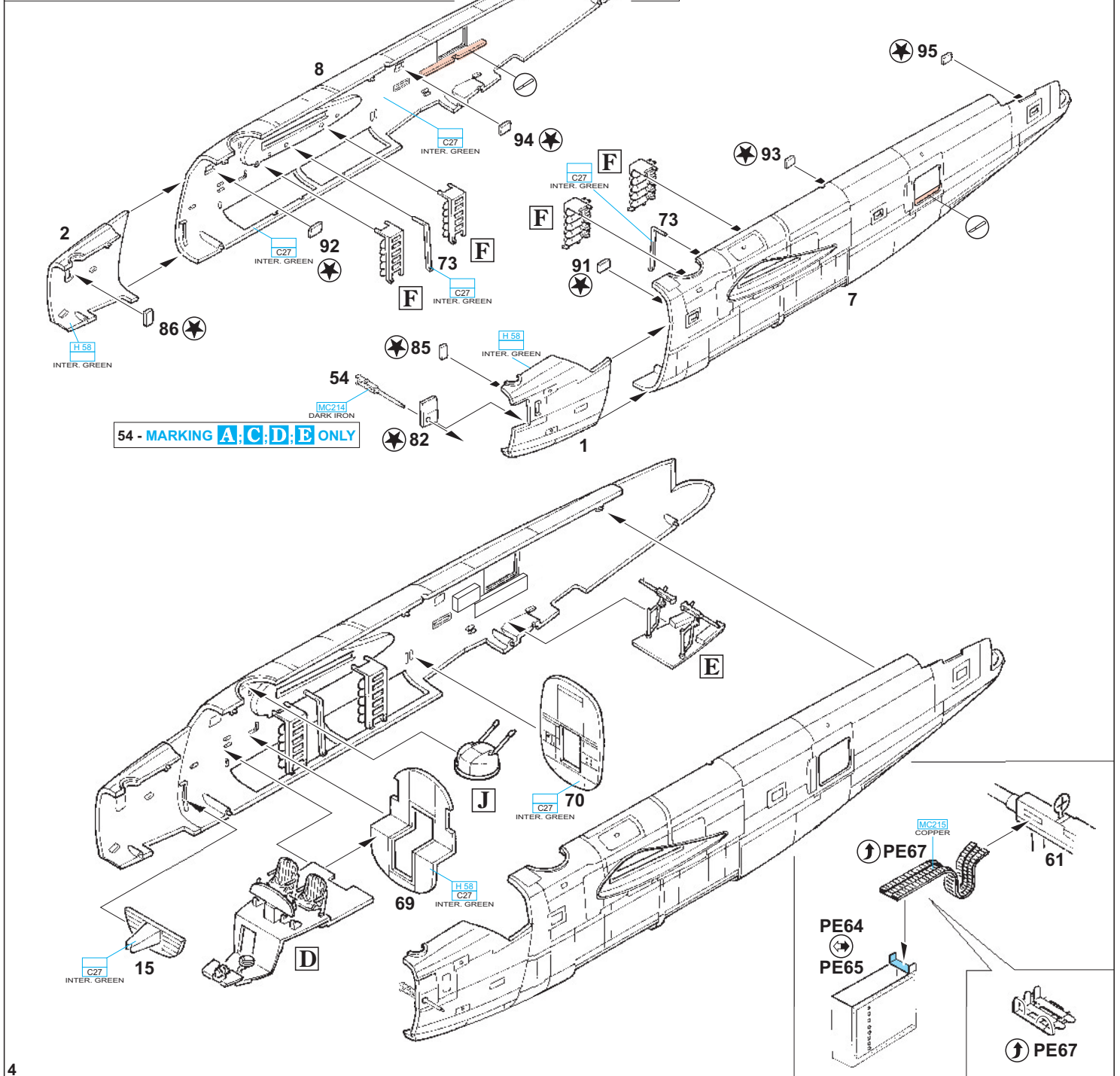
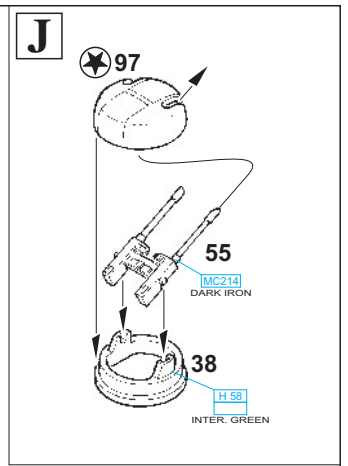
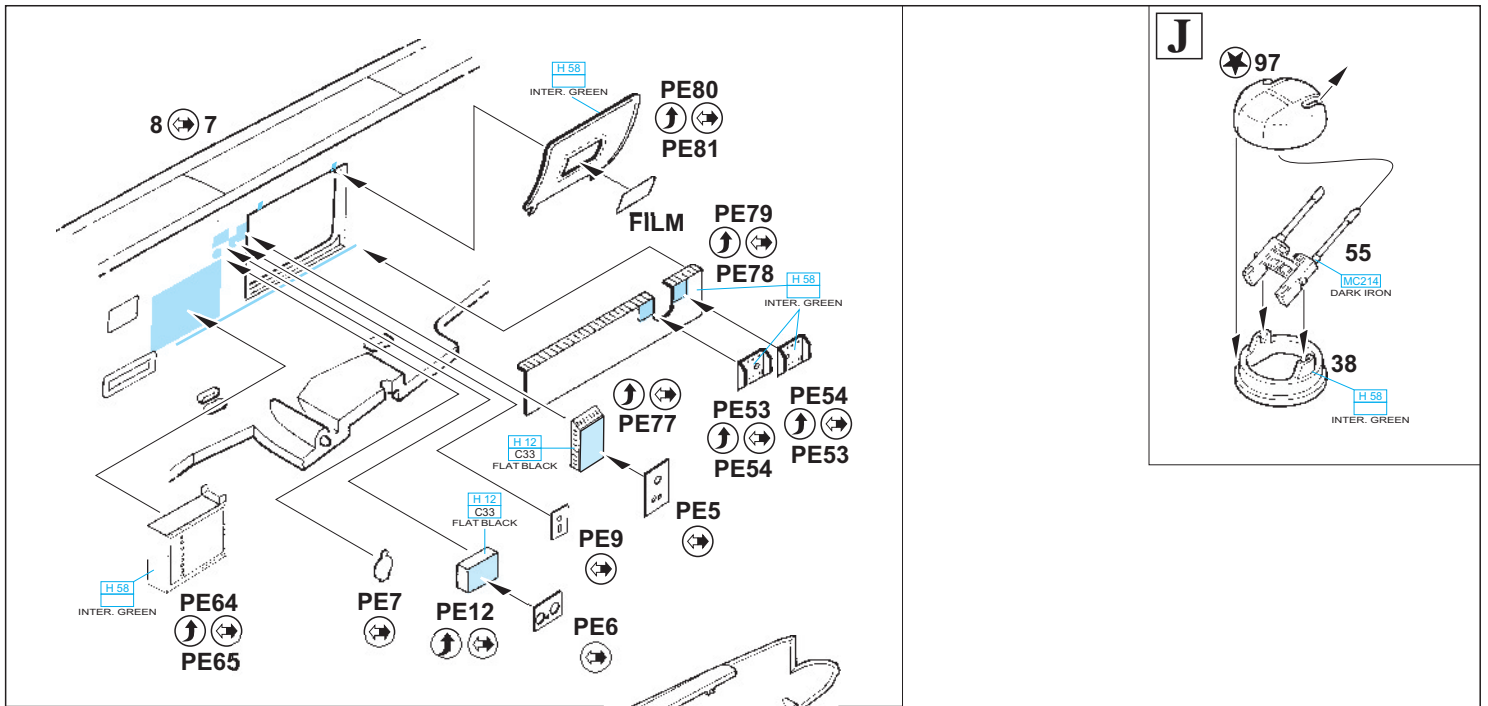

PE73
PE72
PE62
PE71
PE61
PE70

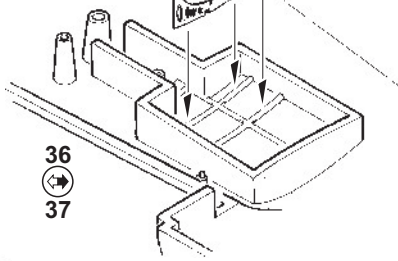

K

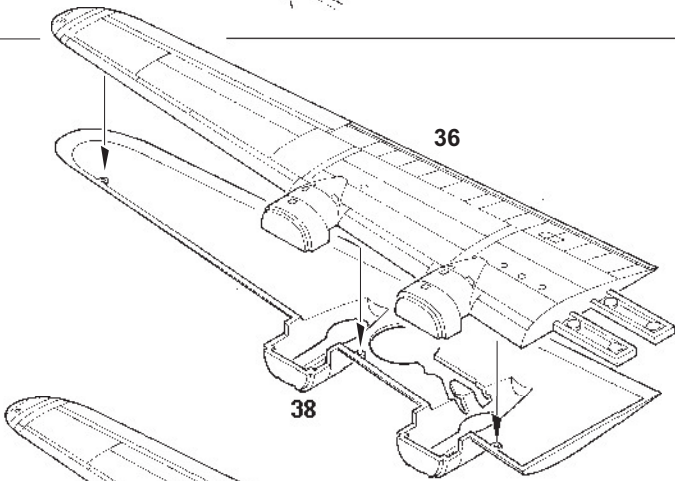
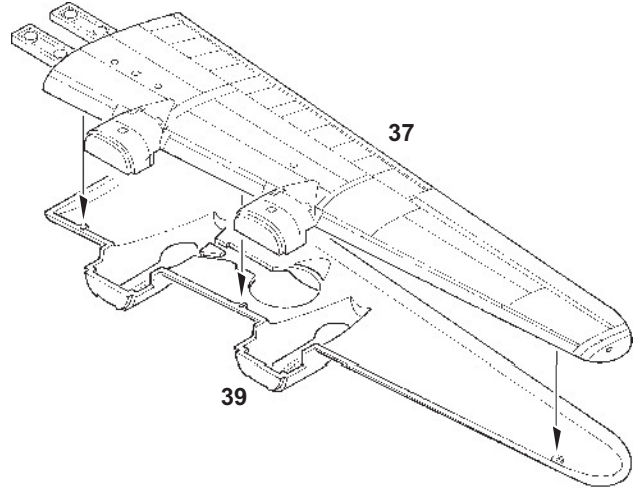
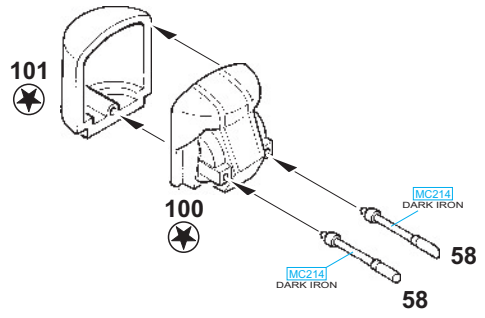

PE83 - MARKING **A; B; D; E** ONLY

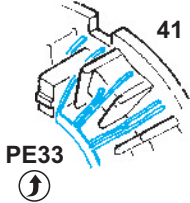
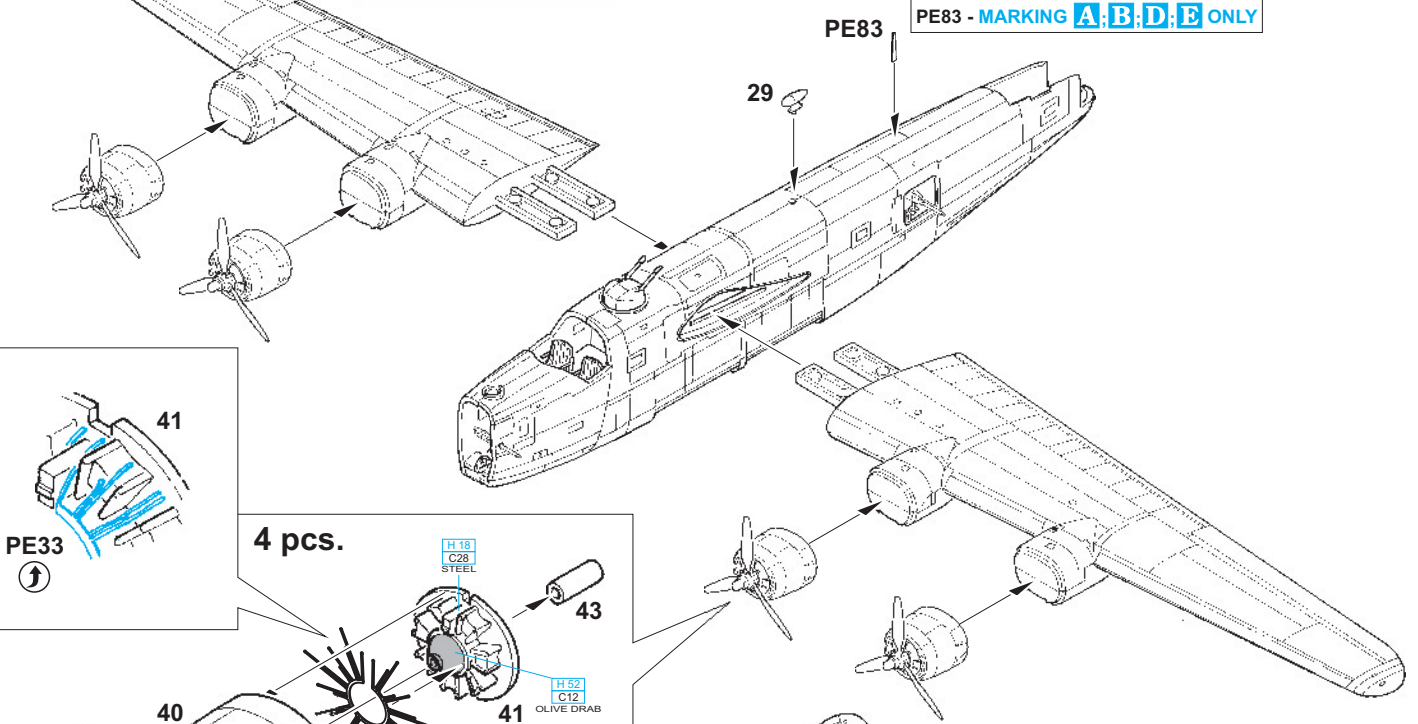

4 pcs.

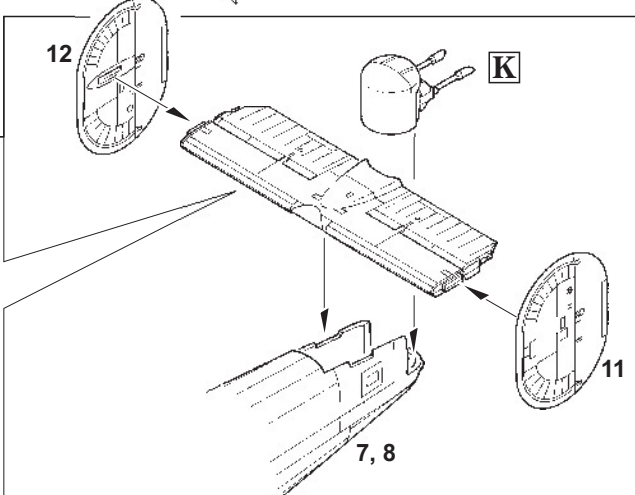
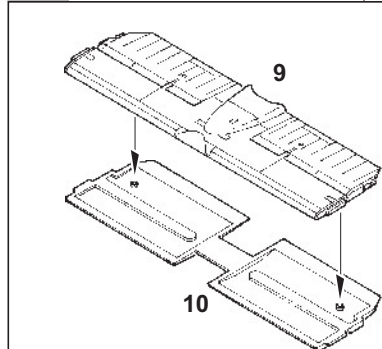
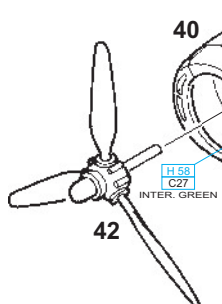
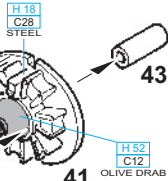

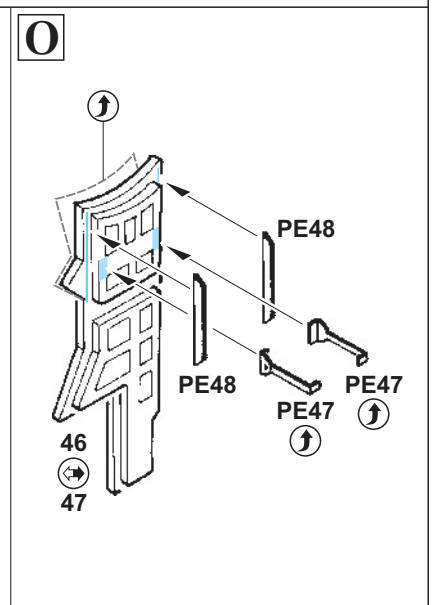
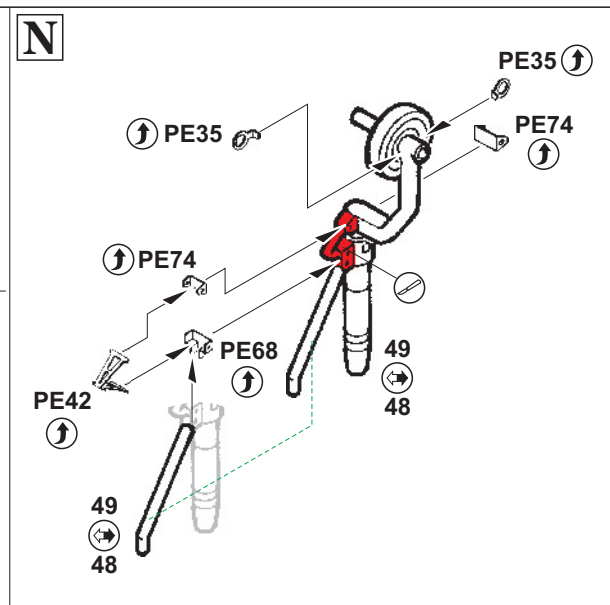
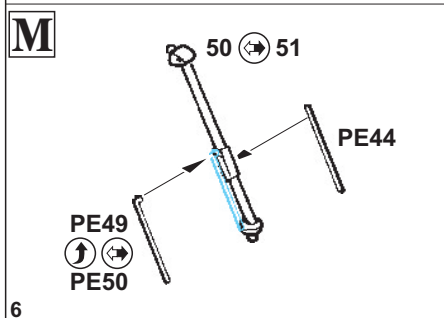
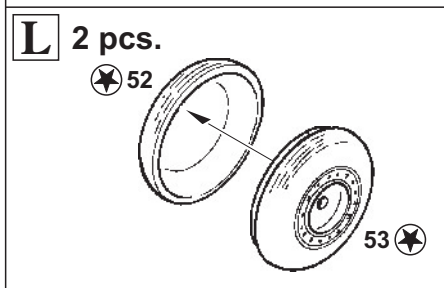
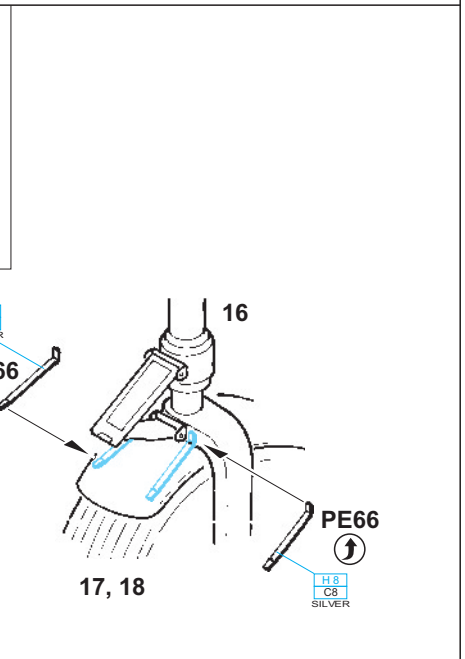
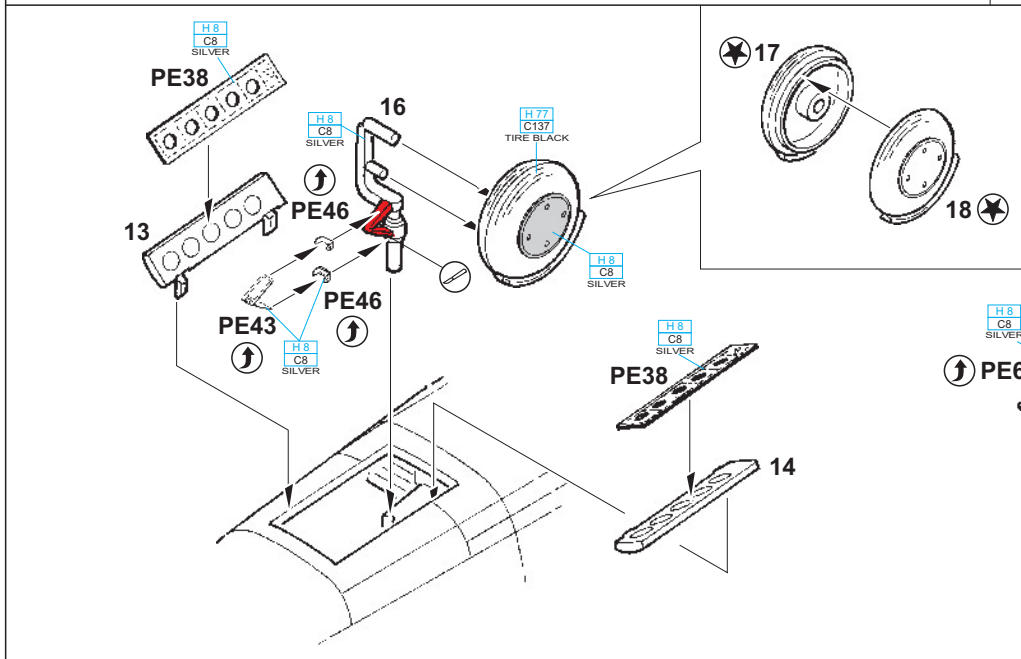
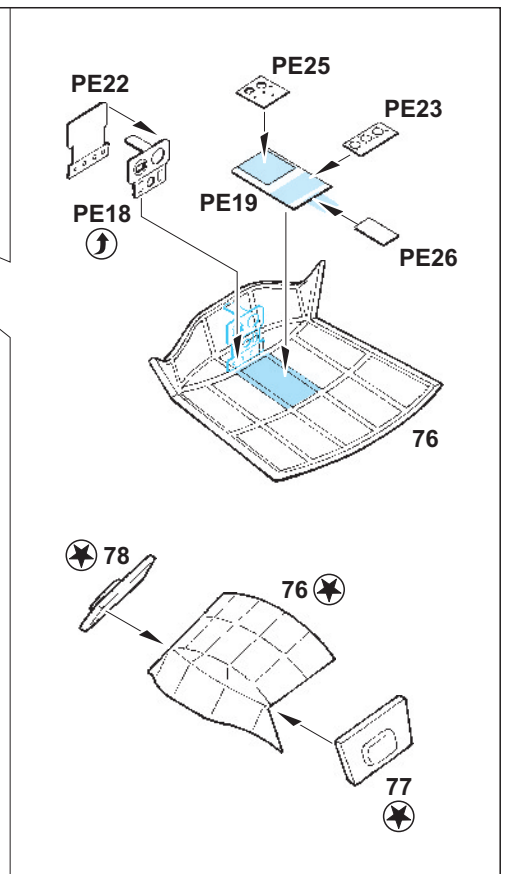
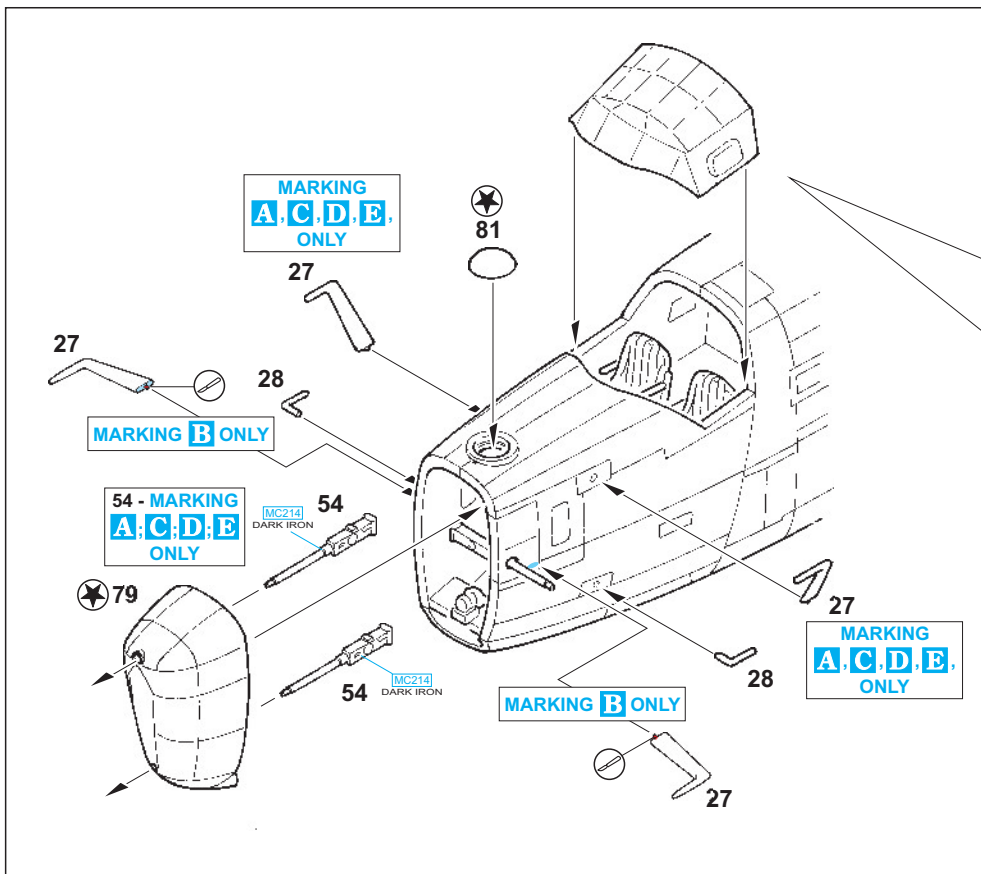

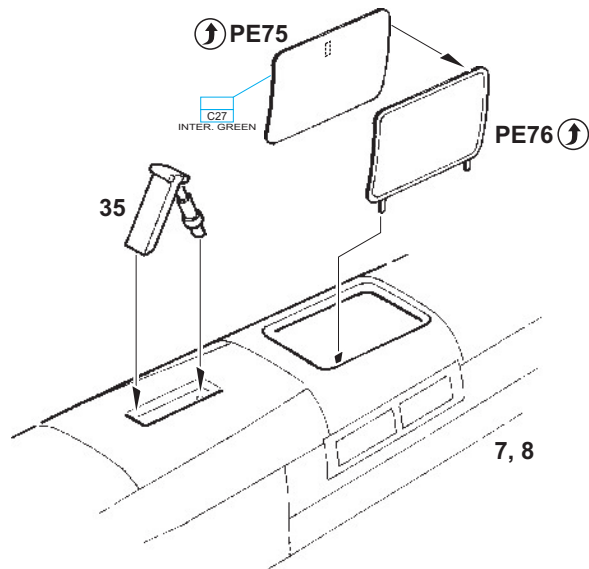
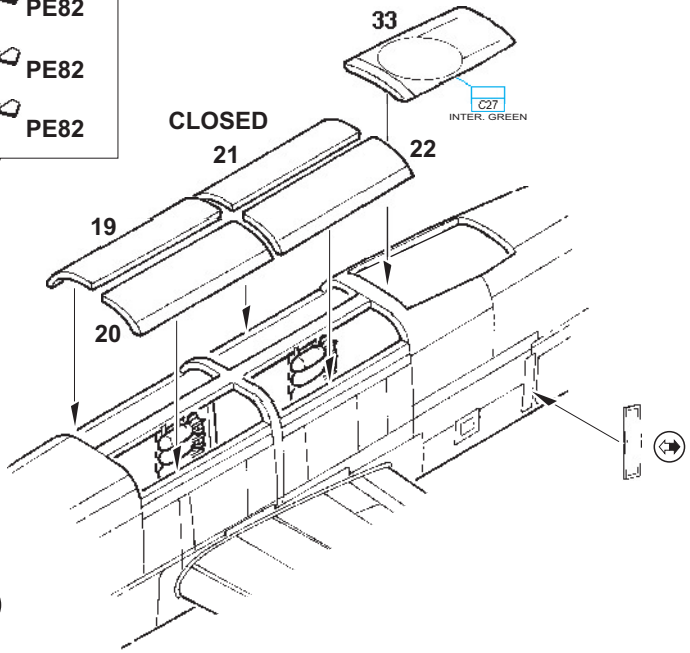
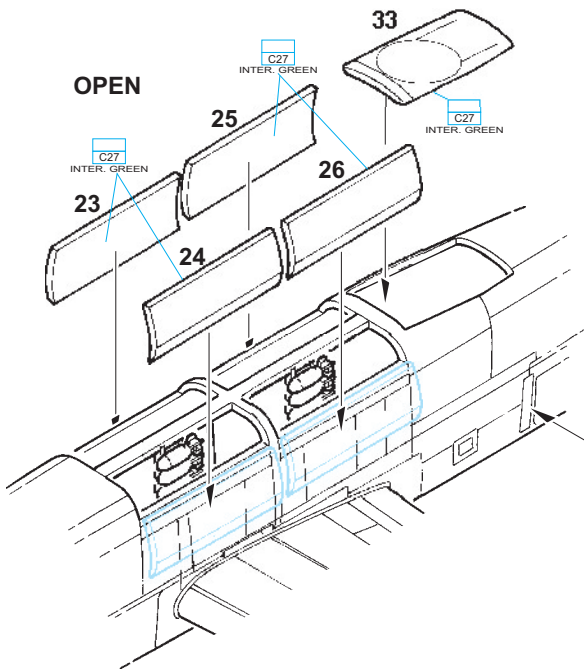
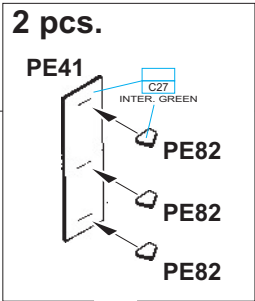
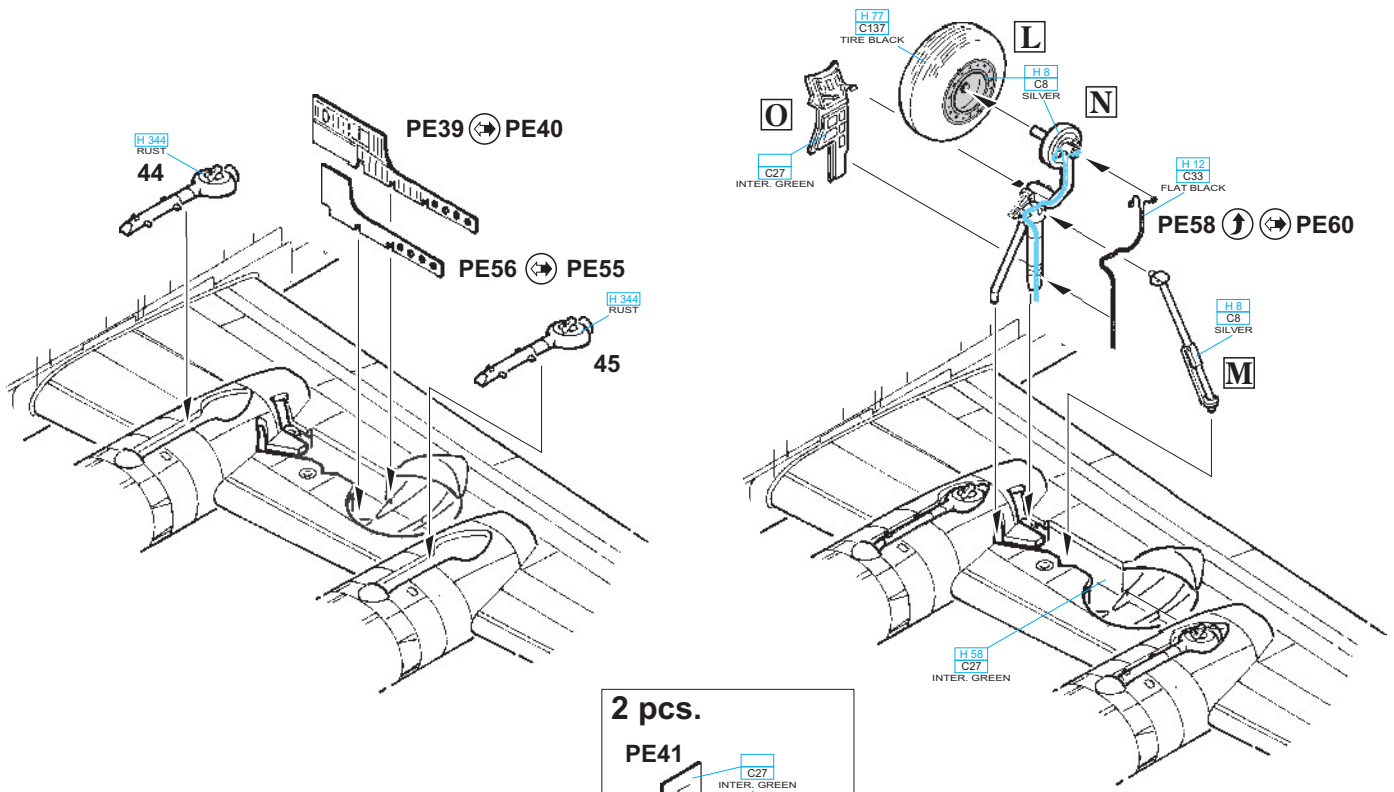

eduard MASK

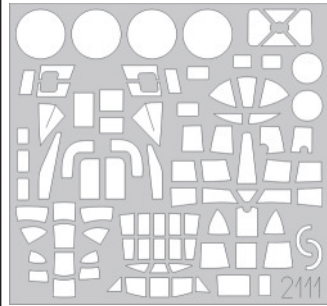

2 pcs.

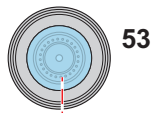

53

2 pcs.

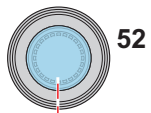

52

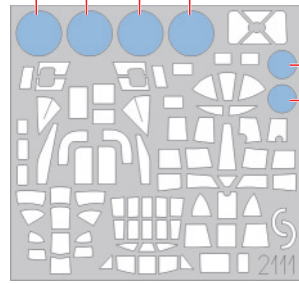

18



17

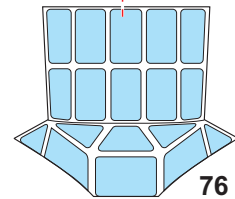
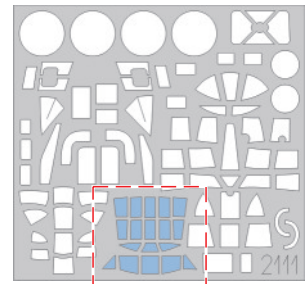

76

97

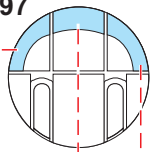

97

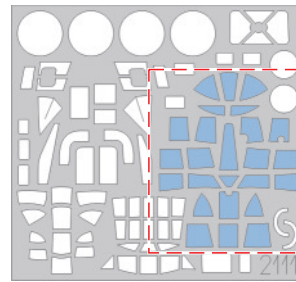
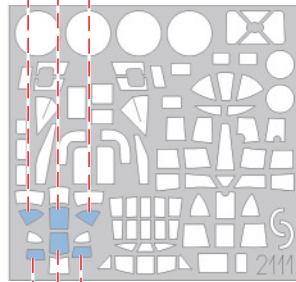
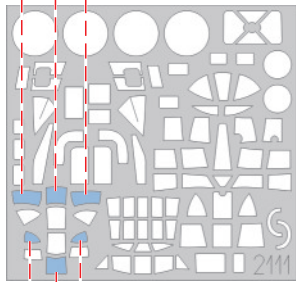
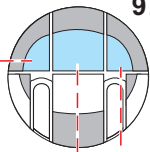

79

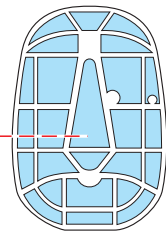

97

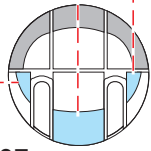

97

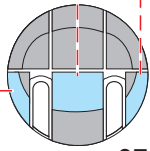

77



78



112

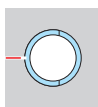

81

94 93 92 91



96

85

86

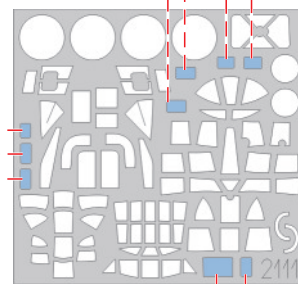

82

95

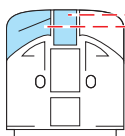

100

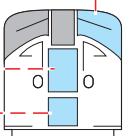
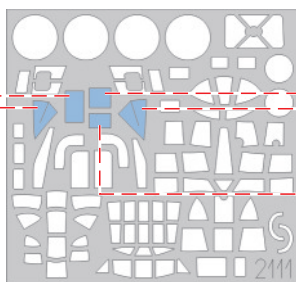

100

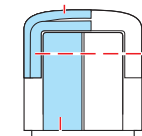

101

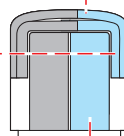
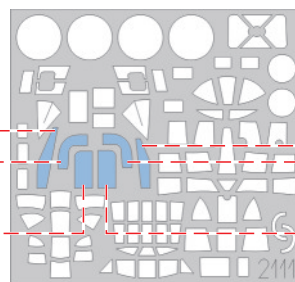

101

A B-24D-CO s/n 41-11766, 98th BG, 345th BS, Lecce AB, Italy, summer, 1944

This aircraft that was commanded by 1st Lt. Leroy B. Morgan, took part on August 1st, 1943, in a raid on Ploesti, in Romania. The 98th BG 'Pyramiders' dispatched 48 Liberators. The return from the Balkan hell that ensued saw only thirteen, one of which was 'CHUG-A-LUG'. The remaining aircraft either didn't even make it as far Ploesti, were shot down, or were forced to land at Malta, Sicily, and Cyprus.

CHUG-A-LUG returned from Ploesti a further two times. After surviving 105 combat missions, it was called back to the States on July 19th, 1944, where it went on a War Bond Tour. The typical USAAF desert scheme consisted of Sand over Neutral Gray. Not typical was the placement of the national insignia on the tops of both wings.

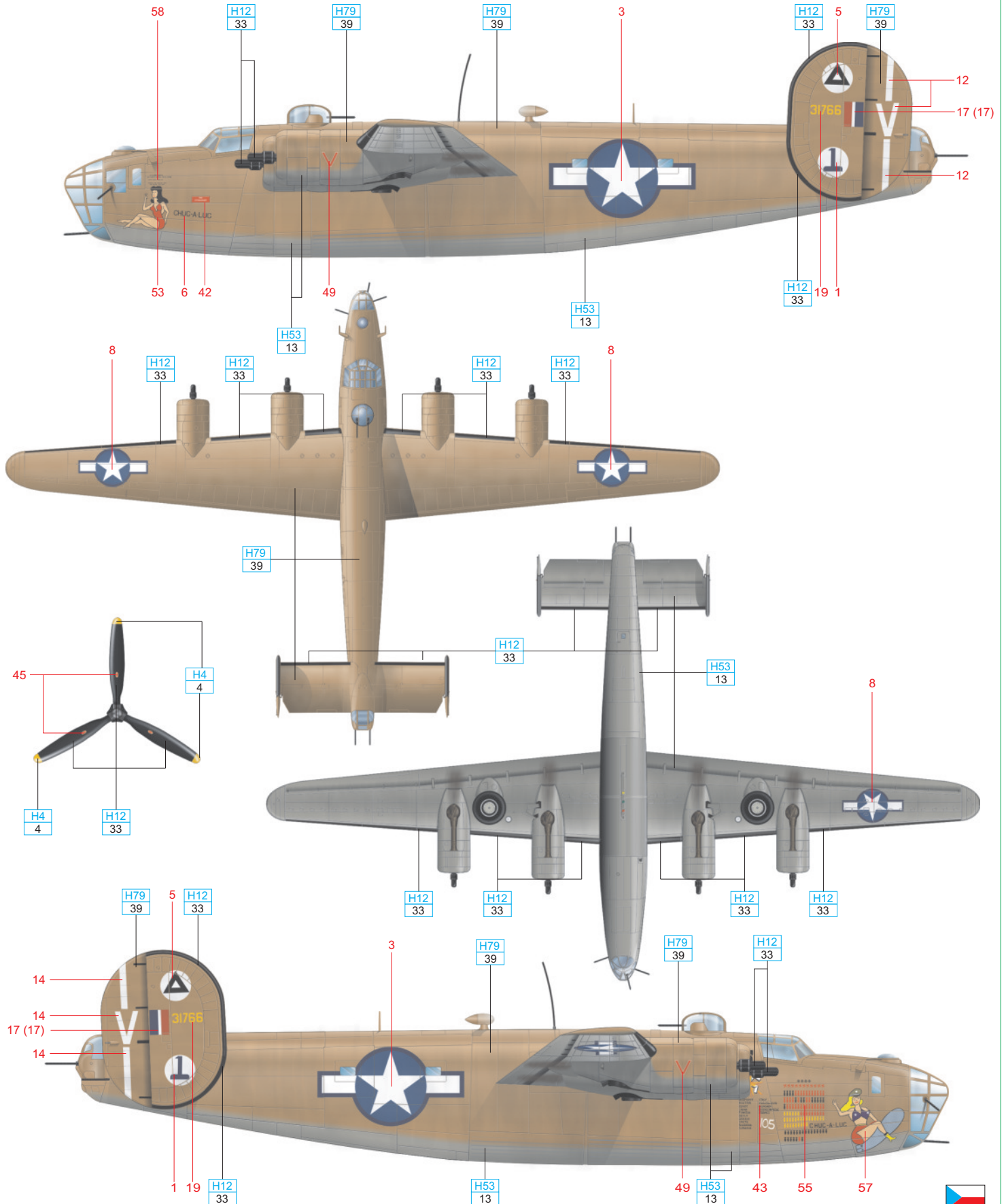

SAND	H79 39	NEUTRAL GRAY	H53 13	BLACK	H12 33	YELLOW	H4 4
------	-----------	--------------	-----------	-------	-----------	--------	---------

ČESKOU VERZI TEXTU NALEZNETE NA
www.eduard.com/info/photos/2111

B B-24D-CO, s/n 41-11613, 376th BG, 514th BS, San Pancrazio AB, Italy, February, 1944

This aircraft was delivered to the USAAF on March 29, 1942, when it arrived at Mobile Air Depot. Less than a month later, on April 22, it was assigned to the HALPRO Unit (Halverson Provisional Unit). This unit was commanded by Col. Harry A. Halverson and was destined for the 10th AF for combat over China. Ultimately, this didn't happen, and the unit remained in north Africa. HALPRO transferred to the 376th Bombardment Group 'Liberandos' in October, 1942. The aircraft carried several names, the first being 'Florence Jo Jo', followed by 'Teggie Ann' and finally 'The Blue Streak'. This aircraft flew a total of 110 missions with the 376th BG. It was then decided to include it in the War Bond Tour. The aircraft was sent back to the States, where, commanded by Capt. Ralph Thompson, it began its participation in the tour in February, 1944. In preparation for the tour, and during the tour itself, the aircraft underwent minor appearance changes. The basis of the decorations was the mission markers, and the map that documented the area of operations, and included crew names, groundcrew names, and their awards. The Olive Drab color on the top was combined with Deep Sky Blue on the lower surfaces.

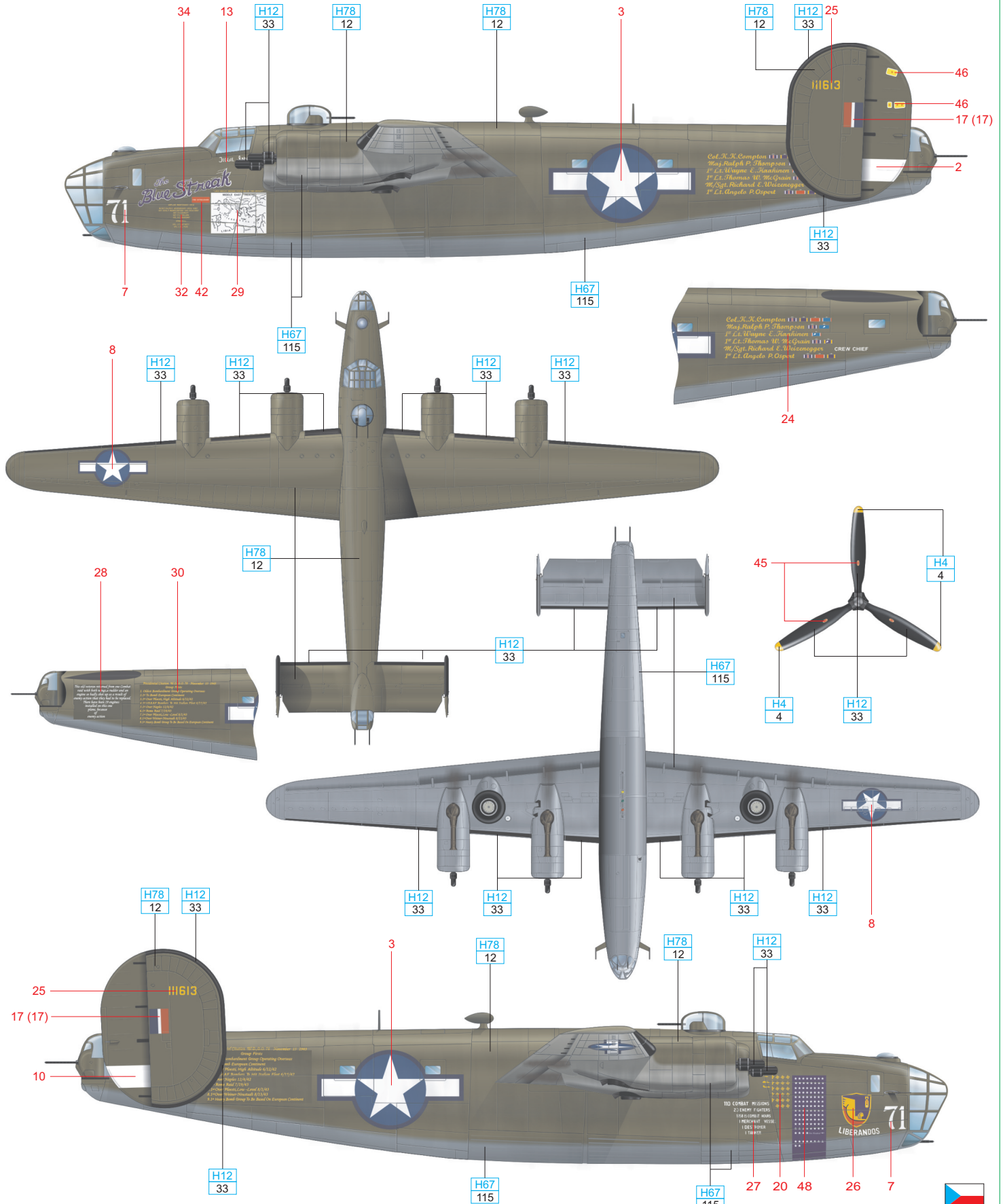

OLIVE DRAB H78
12
DEEP SKY BLUE H67
115
BLACK H12
33
YELLOW H4
4

ČESKOU VERZI TEXTU NALEZNETE NA
www.eduard.com/info/photos/2111

eduard

C B-24D-20-CO, s/n 41-24198, commanded by Capt. Wallace Taylor, 98th BG, 244th BS, Northern Africa, summer, 1943

One of the most famous raids conducted during the Second World War were those aimed at the oil refineries of Ploesti in Romania on August 1st, 1943. This aerial operation codenamed 'Tidal Wave' was intended to take out of commission the oil refinery that at the time accounted for about 35% of all Axis output. Committing 178 bombers from the 9th and 8th AF ended unsuccessfully, however. The production of fuel was back up to previous levels only a few weeks after the raid. The American raid cost 53 aircraft and 660 men.

One aircraft that did not make it back from the raid was 'The Vulgar Virgin'. With the passage of time, it has been difficult to ascertain the original inspiration for the name, but the female likeness on the front hails from Esquire magazine from November, 1941. The aircraft was brought down by a direct hit from AAA fire, and the only survivor was the Captain, Wallace Taylor.

The aircraft was camouflaged in the typical scheme for this theatre of operations, comprising Sand (or Desert Pink) and Neutral Gray.

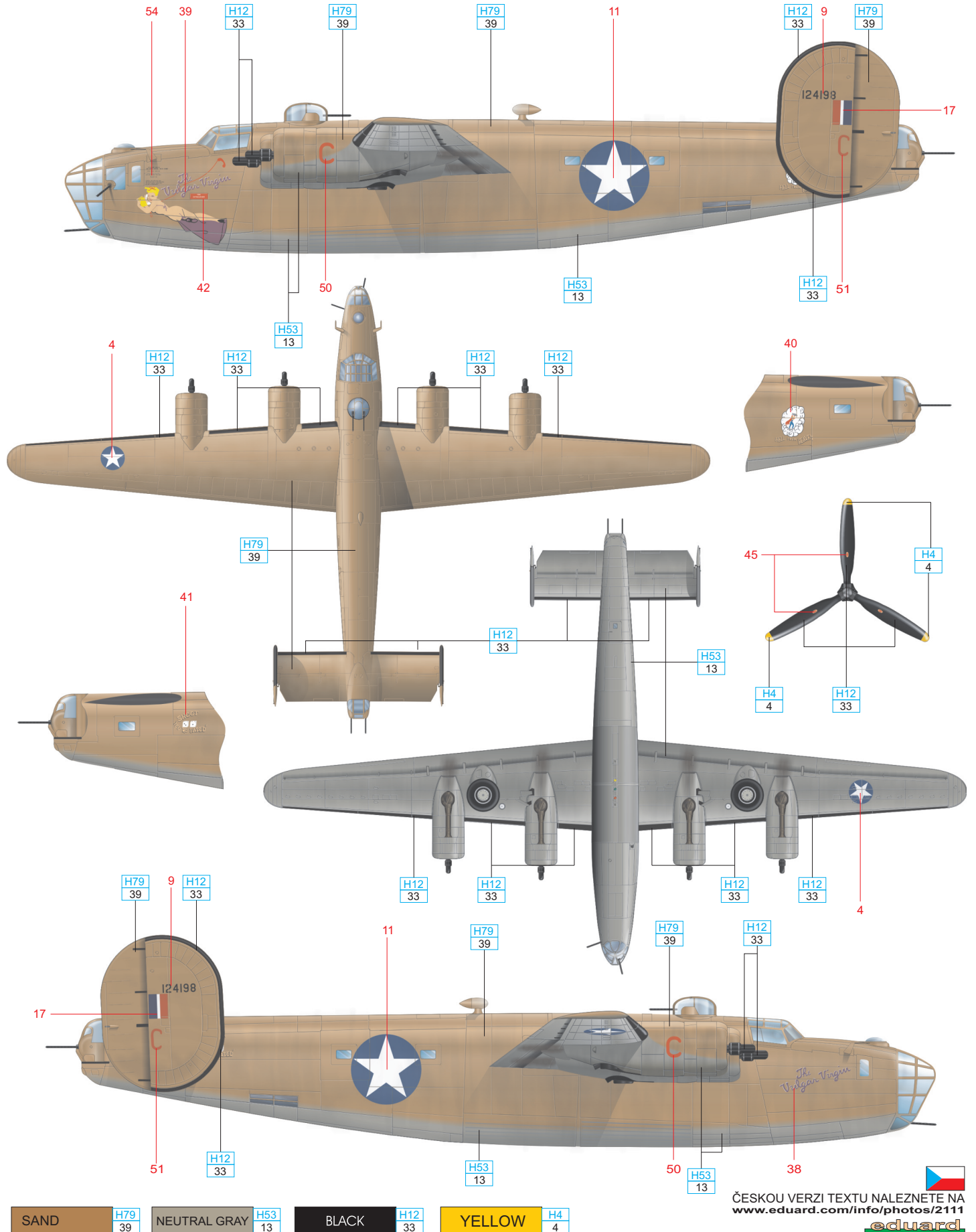

ČESKOU VERZI TEXTU NALEZNETE NA
www.eduard.com/info/photos/2111



eduard

D B-24D-15-CO, s/n 41-24047, 90th BG, 320th BS, Southwest Pacific, late 1943

This Liberator was delivered to the USAAF on October 13th, 1942. By the 23rd of November, it was involved in missions in the SWPTO. The plane was dubbed 'Moby Dick' The aircraft labored for more than one hundred missions, and was selected to participate in the War Bond Tour, which it commenced in October, 1943. After that, Moby Dick was then converted to a TB-24D transport.

The skull and cross-bombs on the tail surface became the unit marking for the 90th Bombardment Group 'Jolly Rogers'. From September, 1943, to the middle of the year, all aircraft had them in black and white. After that, the base color was changed to that of individual squadrons, and the 320th BS had the white skull and red bombs the red background. It was interesting to note the origin of this marking. It had to do with the name of the CO of the 90th BG, Col. Arthur Rogers. Keeping with the pirate theme was not much of a leap from that. The name 'Moby Dick' was not only carried by this aircraft, but all of the 520th BS. The outline was intended to be broken up by the application of medium green fields on the wings and tail surfaces.

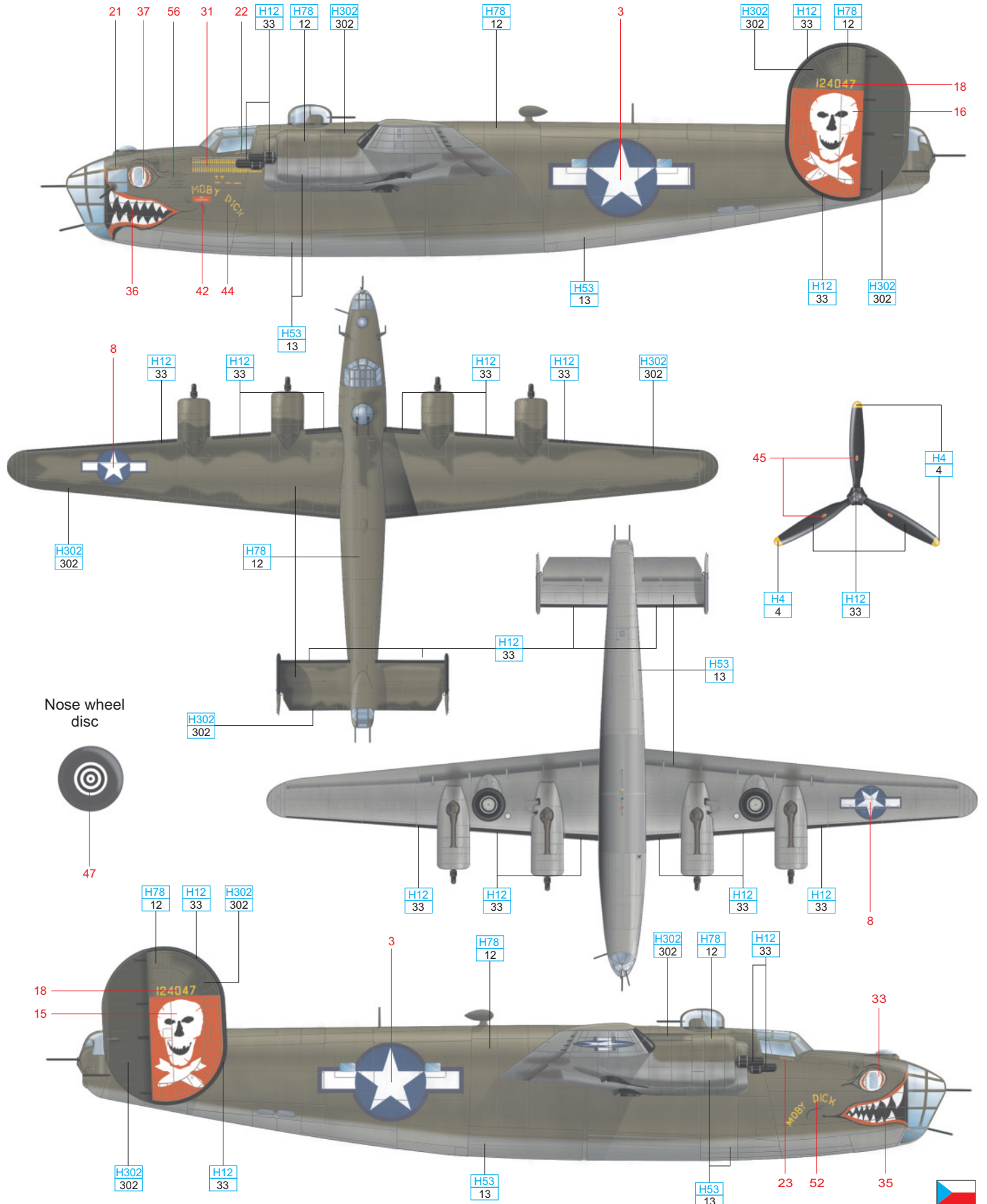

OLIVE DRAB	H78 12	MEDIUM GREEN	H302 302	NEUTRAL GRAY	H53 13	BLACK	H12 33	YELLOW	H4 4
------------	-----------	--------------	-------------	--------------	-----------	-------	-----------	--------	---------

ČESKOU VERZI TEXTU NALEZNETE NA
www.eduard.com/info/photos/2111
 eduard

E B-24D-15-CO, s/n 41-24047, 90th BG, 320th BS, Southwest Pacific, 1943

This Liberator was delivered to the USAAF on October 13th, 1942. By the 23rd of November, it was involved in missions in the SWPTO. The plane was dubbed 'Moby Dick' The aircraft labored for more than one hundred missions, and was selected to participate in the War Bond Tour, which it commenced in October, 1943. After that, Moby Dick was then converted to a TB-24D transport.

The skull and cross-bombs on the tail surface became the unit marking for the 90th Bombardment Group 'Jolly Rogers'. From September, 1943, to the middle of the year, all aircraft had them in black and white. After that, the base color was changed to that of individual squadrons, and the 320th BS had the white skull and red bombs the red background. It was interesting to note the origin of this marking. It had to do with the name of the CO of the 90th BG, Col. Arthur Rogers. Keeping with the pirate theme was not much of a leap from that. The name 'Moby Dick' was not only carried by this aircraft, but all of the 520th BS. The outline was intended to be broken up by the application of medium green fields on the wings and tail surfaces.

